

		PAGINA Page Seite
MODULO MOTORIZZATO RADIALE Radial driven tool Radial angetriebenes Werkzeug		TKW 010.1.00
MODULO MOTORIZZATO RADIALE MOLTIPLICATO 1:2 DISASSATO IN Z 50mm Radial geared-up 1=1:2 driven tool re-directed in Z by 50mm Radial angetriebenes Werkzeug uebersetzt 1=1:2 achsversetzt in Z um 50mm		TKW 030.1.30
MODULO MOTORIZZATO ASSIALE Axial driven tool Axial angetriebenes Werkzeug		TKW 150.1.10
MODULO MOTORIZZATO ASSIALE BISPORGENTE Axial opposite face driven tool Axial angetriebenes Werkzeug halb vorspringend		TKW 240.1.10
MODULO MOTORIZZATO ORIENTABILE ±90° ±90° adjustable angle driven tool Angetriebenes Werkzeug schwenkbar ±90°		TKW 335.1.00
MODULO MOTORIZZATO ORIENTABILE ±90° CON NONIO DIGITALE ±90° adjustable angle driven tool with digital display Angetriebenes Werkzeug schwenkbar ±90° mit digital display		TKW 335.1.01
MODULO MOTORIZZATO ORIENTABILE ±90° MOLTIPLICATO 1:2 ±90° adjustable angle driven tool geared-up 1=1:2 Angetriebenes Werkzeug schwenkbar ±90° uebersetzt 1=1:2		TKW 336.1.00
MOD. MOTORIZZ. ORIENTABILE ±90° MOLTIPL. 1:2 CON NONIO DIGITALE ±90° adjustable angle driven tool geared-up 1=1:2 with digital display Angetriebenes Werkzeug schwenkbar ±90° uebersetzt 1=1:2 mit digital display		TKW 336.1.01
PORTAUTENSILE RADIALE SINGOLO QD=25mm Radial single static tool QD=25mm Radial Single-Werkzeughalter QD=25mm		TKW 423.1.00
PORTAUTENSILE RADIALE DOPPIO QD=25mm Radial double static tool QD=25mm Radial Doppel-Werkzeughalter QD=25mm		TKW 453.1.00
PORTAUTENSILE RADIALE PER LAMA Radial blade holder Radial Abstechhalter		TKW 510.1.00
PORTAUTENSILE ASSIALE SINGOLO QD=25mm Axial single static tool QD=25mm Axial Single-Werkzeughalter QD=25mm		TKW 552.1.00

		PAGINA Page Seite
<p>PORTAUTENSILE ASSIALE PER BARENO \varnothing32mm H=90mm Axial single boring bar holder \varnothing32mm H=90mm Axial Bohrhalter \varnothing32mm H=90mm</p>		TKW 660.1.10

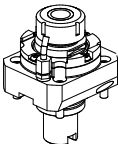
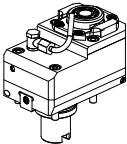
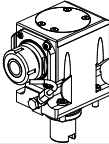
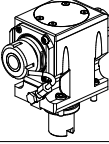
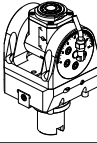
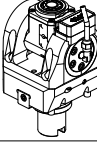
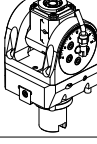
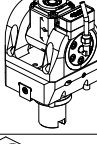
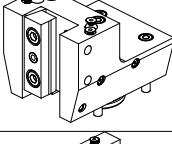
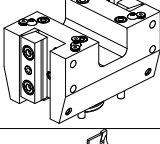
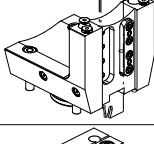
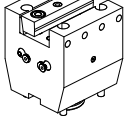
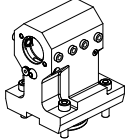
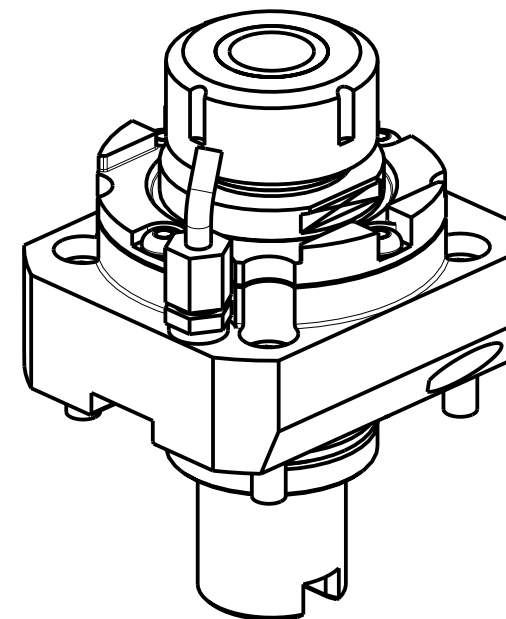
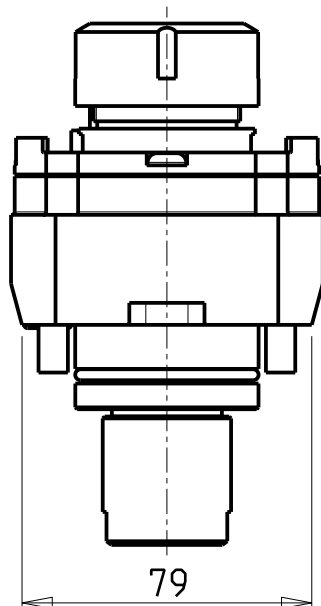
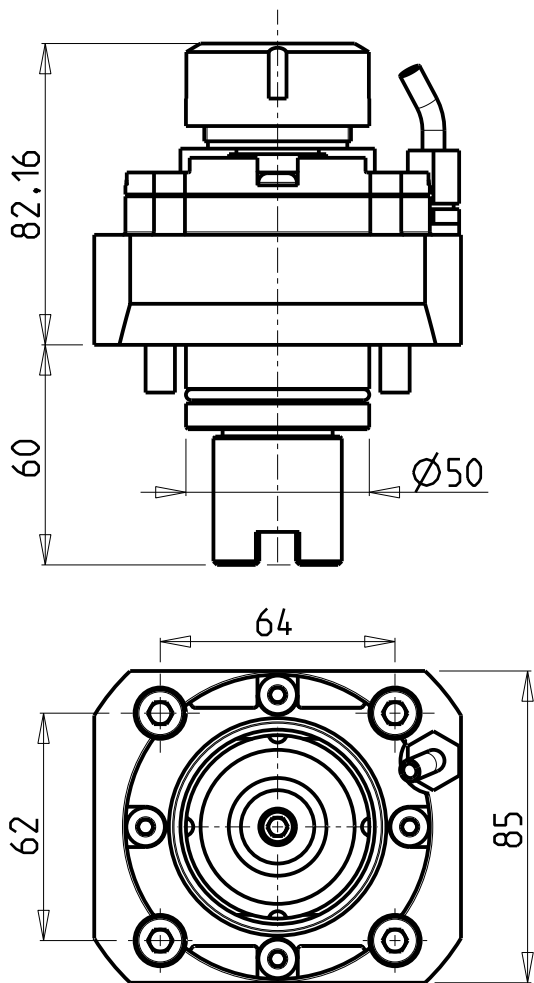

Cod. MT	Mandrino Spindle Spindel	I	RPM	Coppia Max Max Torque Max Drehmoment	Lubrificazione est. Ext. coolant Aussenkuehlung	CHIAVI NON INCLUSE Keys not included Schlüssel nicht einbegriffen
TKW 0020132	ER32	1:1	6000	65Nm	X	CHSTER32 OKU0650004 ■

- Chiave inclusa
- Key included
- Schlüssel inbegriffen

TAKISAWA
MOD: TCY160/200

MODULO MOTORIZZATO RADIALE
Radial driven tool
Radial angetriebenes Werkzeug

Subject to change without notice.

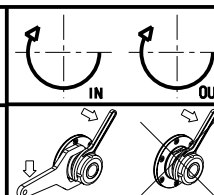

M.T. srl
Via Casino Albini 480
Tel. 0541/956034-957884
Fax 0541/956341
47842 S. GIOVANNI IN M. (RN)
e-mail: mtma@mtmarchetti.com
http://www.mtmarchetti.com

PRODUZIONE MODULI ROTANTI



PAGINA TKW 010-1-00

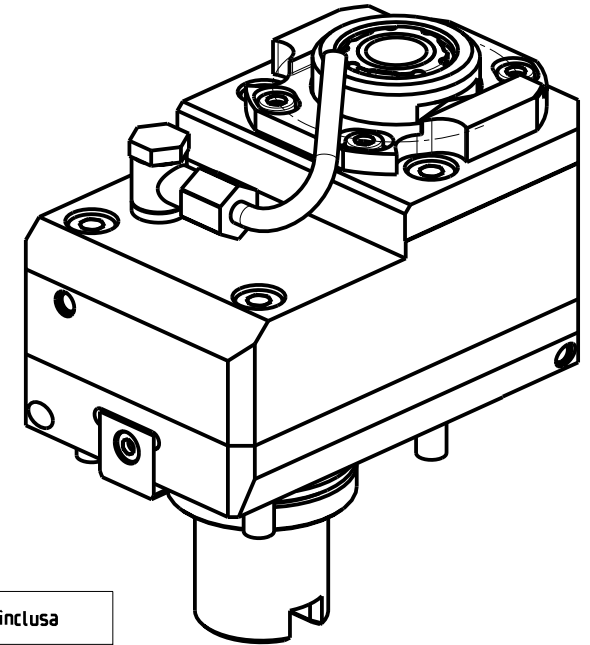
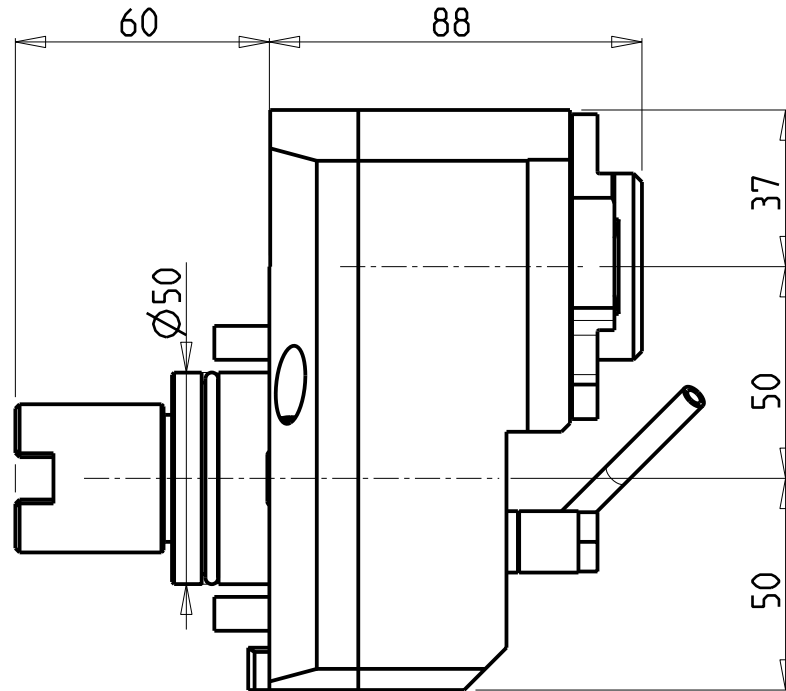
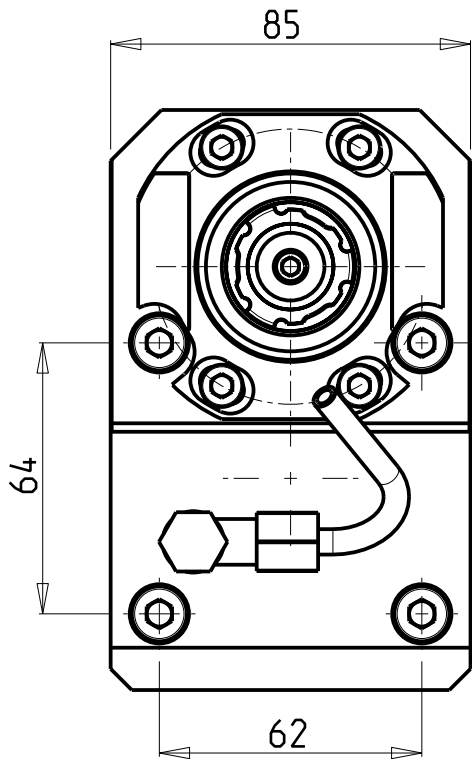

- Chiave inclusa
- Key included
- Schlüssel inbegriffen

Cod. MT	Mandrino Spindle Spindel	i	RPM MAX	Coppia Max Max Torque Max Drehmoment	Reversibile lato mandrino/contromandrino Reversible sub/main spindle side Umkehrbare Spindel-seite/ Gegenspindel-seite	Lubrificazione int. Coolant through Innenkuehlung	Lubrificazione est. Ext. coolant Aussenkuehlung	CHIAVI NON INCLUSE Keys not included Schlüssel nicht einbegriffen		
TKW 0222125	ERA25	1:2	12000	40Nm	X		X	CHUB27	CHTAER25ZC	OKU0290009
TKW 0222225	ERA25	1:2	12000	40Nm	X	P=70bar	X	CHUB27	CHTAER25ZC	OKU0290009

TAKISAWA
MOD: TCY160/200

MODULO MOTORIZZATO RADIALE MOLTIPLICATO I=1:2 DISASSATO IN Z 50mm
Radial geared-up I=1:2 driven tool re-directed in Z by 50mm
Radial angetriebenes Werkzeug uebersetzt I=1:2 achsversetzt in Z um 50mm

Subject to change without notice.

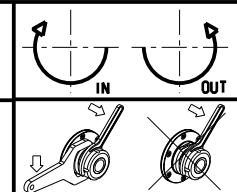

M.T. srl
Via Casino Albini 480
Tel. 0541/956034-957884
Fax 0541/956341
47842 S. GIOVANNI IN M. (RN)
e-mail: mtma@mtmarchetti.com
http://www.mtmarchetti.com

PRODUZIONE MODULI ROTANTI



PAGINA TKW 030-1-30

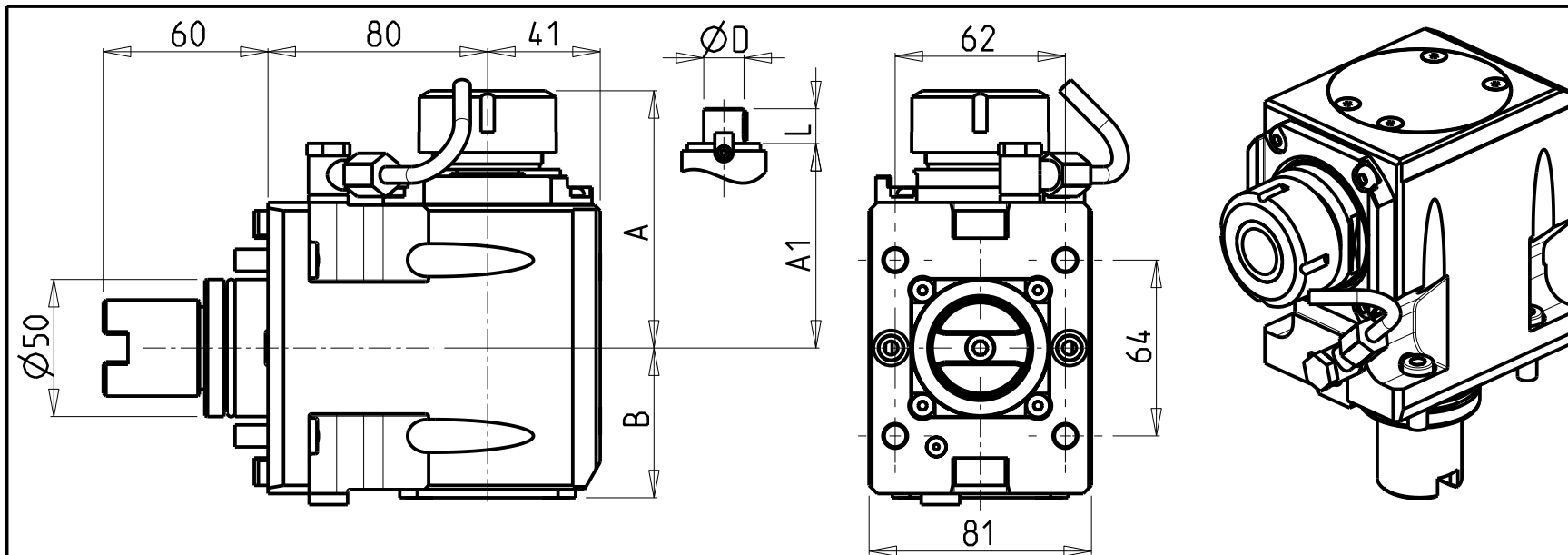

ATTENZIONE - ATTENTION - ACHTUNG

- Per lo smontaggio degli utensili utilizzare sempre la chiave di contrasto come indicato nel manuale d'uso.
- For disassembly of the tools use always the contrast key as mentioned in the user instructions.
- Fuer das Abmontieren der Werkzeuge immer den Gegenschlüssel benutzen wie in der Bedienungsanleitung erwaeht.

- Chiave inclusa
- Key included
- Schlüssel inbegriffen

Cod. MT	Mandrino Spindle Spindel	I	RPM	Coppia Max Max Torque Max Drehmoment	Reversibile lato mandrino/contromandrino Reversible sub/main spindle side Umkehrbare Spindel-seite/ Gegenspindel-seite	Lubr.interna Coolant through Innenkuehlung	Lubr.esterna Ext. coolant Aussenkuehlung	A	A1	B	D	L	CHIAVI NON INCLUSE Keys not included Schlüssel nicht einbegriffen		
TKW 0010125	ER25	1:1	6000	65Nm	X	-	X	91.16	-	57	-	-	-	CHSTER25	OKU0650004 *
TKW 0010132	ER32	1:1	6000	65Nm	X	-	X	93.66	-	57	-	-	-	CHSTER32	OKU0650004 *
TKW 0010140	ER40	1:1	6000	65Nm	X	-	X	98.16	-	57	-	-	-	CHSTER40	OKU0650004 *
TKW 0010325	ERA25	1:1	6000	65Nm	X	-	X	65	-	57	-	-	CHUB27	CHTAER25ZC *	OKU0650004 *
TKW 0010225	ER25	1:1	6000	65Nm	X	P=70bar	X	91.16	-	67	-	-	-	CHSTER25	OKU0650004 *
TKW 0010232	ER32	1:1	6000	65Nm	X	P=70bar	X	93.66	-	67	-	-	-	CHSTER32	OKU0650004 *
TKW 0010240	ER40	1:1	6000	65Nm	X	P=70bar	X	98.16	-	67	-	-	-	CHSTER40	OKU0650004 *
TKW 0010425	ERA25	1:1	6000	65Nm	X	P=70bar	X	65	-	67	-	-	CHUB27	CHTAER25ZC *	OKU0650004 *
TKW 0010516	Ø16x17	1:1	6000	65Nm	X	-	X	-	67.5	-	16	17	-	CH_VTCROCE_M08 *	OKU0650004 *
TKW 0010522	Ø22x19	1:1	6000	65Nm	X	-	X	-	67.5	-	22	19	-	CH_VTCROCE_M10 *	OKU0650004 *
TKW 0010527	Ø27x21	1:1	6000	65Nm	X	-	X	-	70	-	27	21	-	CH_VTCROCE_M12 *	OKU0650004 *

TAKISAWA
MOD: TCY160/200

MODULO MOTORIZZATO ASSIALE
Axial driven tool
Axial angetriebenes Werkzeug

Subject to change without notice.

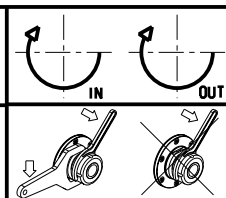

M.T. srl
Via Casino Albini 480
Tel. 0541/956034-957884
Fax 0541/956341
47842 S. GIOVANNI IN M. (RN)
e-mail: mtma@tmarchetti.com
http://www.tmmarchetti.com

PRODUZIONE MODULI ROTANTI



PAGINA TKW 150-1-10

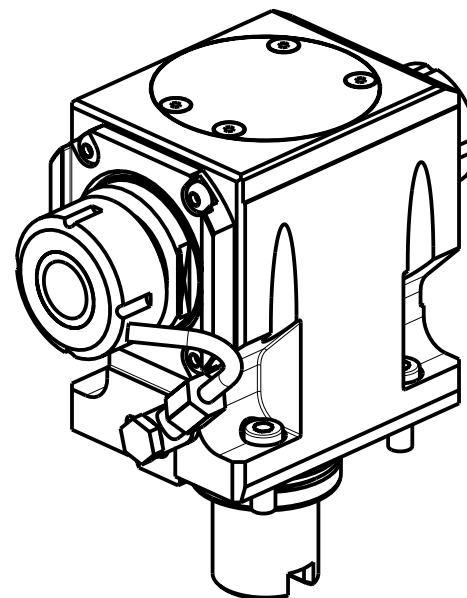
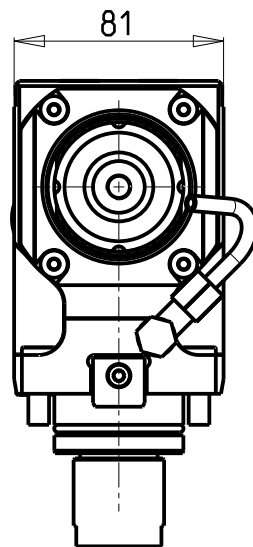
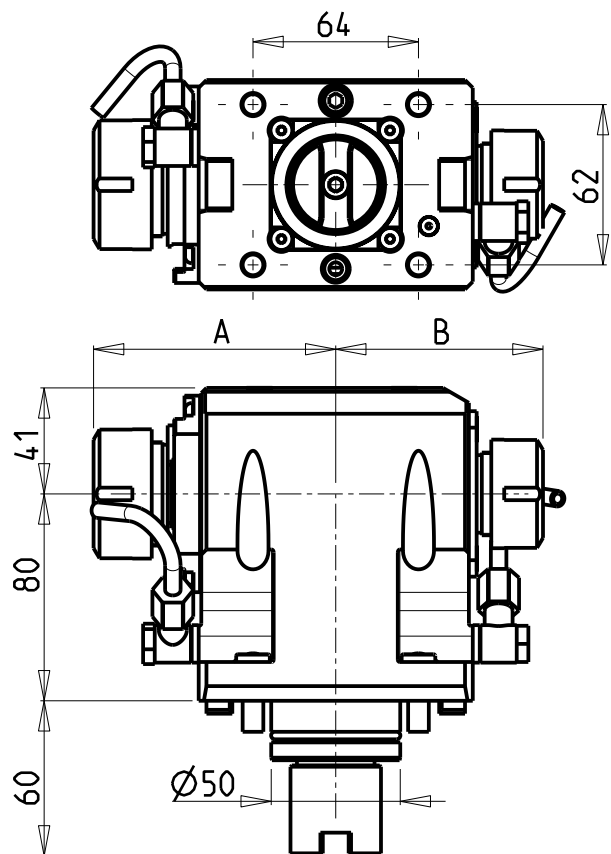

ATTENZIONE - ATTENTION - ACHTUNG

- Per lo smontaggio degli utensili utilizzare sempre la chiave di contrasto come indicato nel manuale d'uso.
- For disassembly of the tools use always the contrast key as mentioned in the user instructions.
- Fuer das Abmontieren der Werkzeuge immer den Gegenschlüssel benutzen wie in der Bedienungsanleitung erwaeht.

- Chiave inclusa
- Key included
- Schluessel inbegriffen

CHIAVI NON INCLUSE
Keys not included
Schluessel nicht einbegriffen

Cod. MT	Mandrino Spindle Spindel	I	RPM	Coppia Max Max Torque Max Drehmoment	Reversibile lato mandrino/contromandrino Reversible sub/main spindle side Umkehrbare Spindel-seite/ Gegenspindel-seite	Lubrificazione est. Ext. coolant Aussenkuehlung	A	B						
TKW 0033225	ER32+ER25	1:1	6000	65Nm	X	X	93.66	80.16	CHSTER32	CHSTER25	OKU0650004	-	-	-
TKW 0032520	ERA25+ERA20	1:1	6000	65Nm	X	X	65	55.5	CHUB22	CHUB27	OKU0650004	CHTAER20ZC	CHTAER25ZC	

TAKISAWA
MOD: TCY160/200
MODULO MOTORIZZATO ASSIALE BISPORGENTE
 Axial opposite face driven tool
 Axial angetriebenes Werkzeug halb vorspringend
 Subject to change without notice.

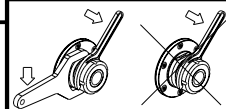

M.T. srl
 Via Casino Albini 480
 Tel. 0541/956034-957884
 Fax 0541/956341
 47842 S. GIOVANNI IN M. (RN)
 e-mail: mtma@mtmarchetti.com
 http://www.mtmarchetti.com

PRODUZIONE MODULI ROTANTI



PAGINA TKW 240-1-10

ATTENZIONE - ATTENTION - ACHTUNG

- Per lo smontaggio degli utensili utilizzare sempre la chiave di contrasto come indicato nel manuale d'uso.
- For disassembly of the tools use always the contrast key as mentioned in the user instructions.
- Fuer das Abmontieren der Werkzeuge immer den Gegenschlüssel benutzen wie in der Bedienungsanleitung erwäohnt.

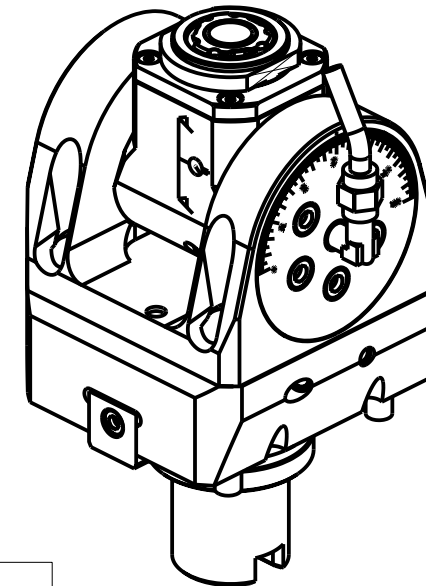
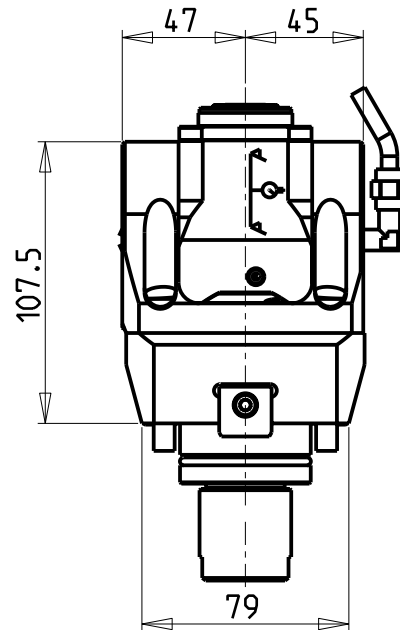
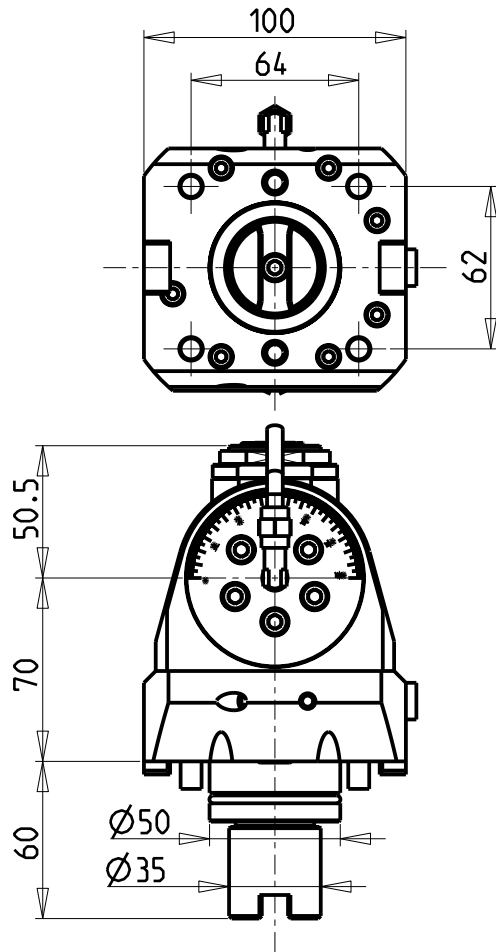

Cod. MT	Mandrino Spindle Spindel	I	RPM	Coppia Max Max Torque Max Drehmoment	Lubrificazione int. Coolant through Innenkuehlung	Lubrificazione est. Ext. coolant Aussenkuehlung	CHIAVI INCLUSE Keys included Schluesssel inbegriffen			
TKW 0500120	ERA20	1:1	6000	30Nm	-	X	CHUB36	CHUB22	CHESL06	CHTAER20ZC
TKW 0500220	ERA20	1:1	6000	30Nm	P=70bar	X	CHUB36	CHUB22	CHESL06	CHTAER20ZC

TAKISAWA
MOD: TCY160/200

MODULO MOTORIZZATO ORIENTABILE +/-90° H=70mm
+/-90° adjustable angle driven tool H=70mm
Angetriebenes Werkzeug schwenkbar +/-90° H=70mm

Subject to change without notice.

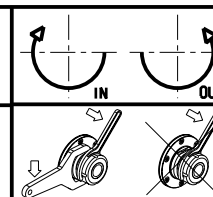

M.T. srl
Via Casino Albini 480
Tel. 0541/956034-957884
Fax 0541/956341
47842 S. GIOVANNI IN M. (RN)
e-mail: mtma@mtmarchetti.com
http://www.mtmarchetti.com

PRODUZIONE MODULI ROTANTI



PAGINA TKW 335-1-00

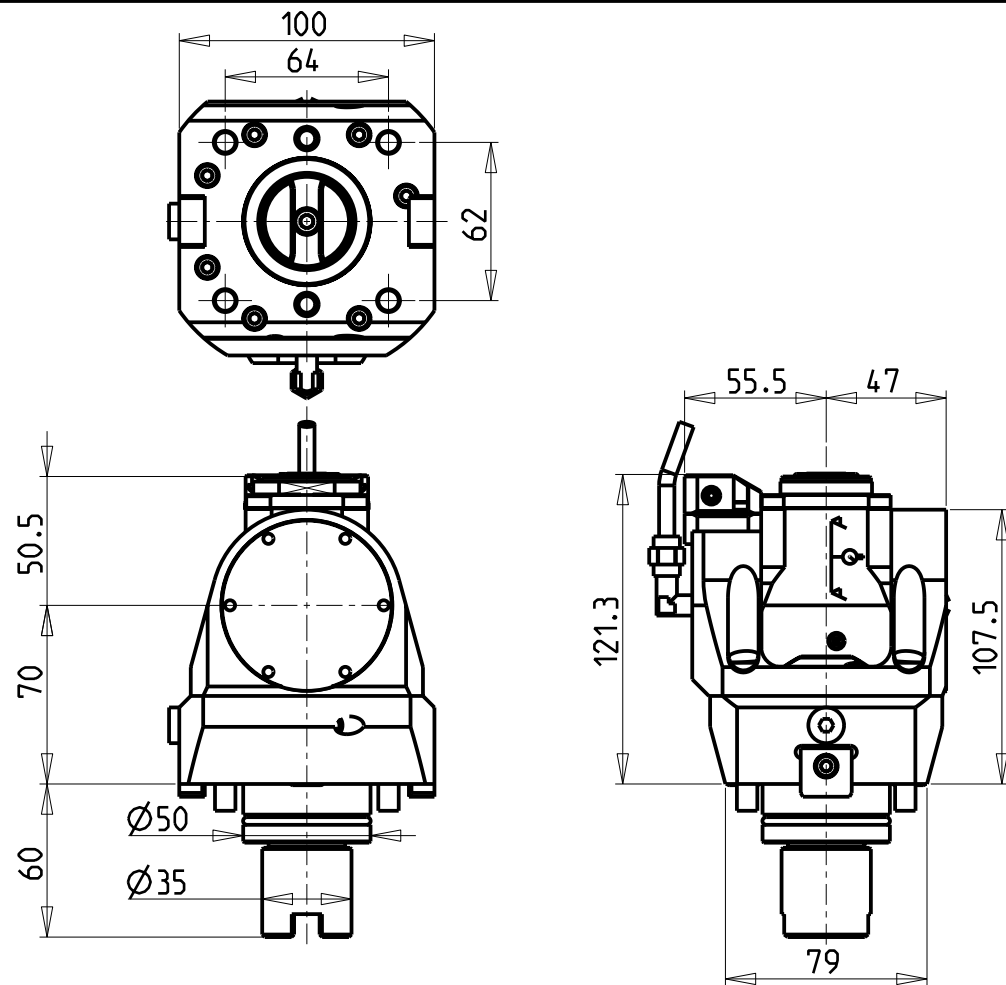

ATTENZIONE - ATTENTION - ACHTUNG

- Per lo smontaggio degli utensili utilizzare sempre la chiave di contrasto come indicato nel manuale d'uso.
- For disassembly of the tools use always the contrast key as mentioned in the user instructions.
- Fuer das Abmontieren der Werkzeuge immer den Gegenschuessel benutzen wie in der Bedienungsanleitung erwaehnt.

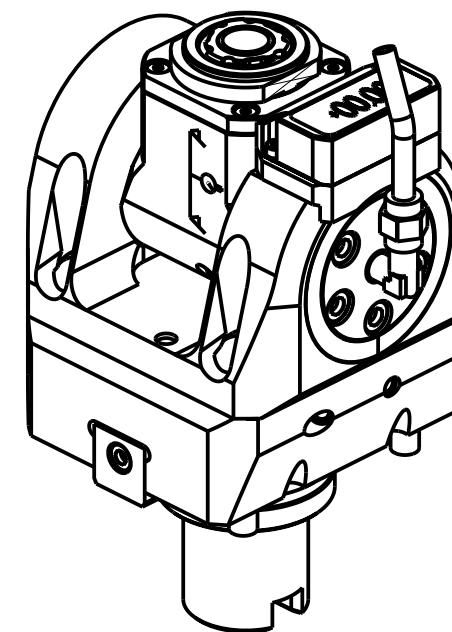

Cod. MT	Mandrino Spindle Spindel	I	RPM	Coppia Max Max Torque Max Drehmoment	Lubrificazione int. Coolant through Innenkuehlung	Lubrificazione est. Ext. coolant Aussenkuehlung	CHIAVI INCLUSE Keys included Schluessel inbegriffen			
TKW 0505120	ERA20	1:1	6000	30Nm	-	X	CHUB36	CHUB22	CHESL06	CHTAER20ZC
TKW 0505220	ERA20	1:1	6000	30Nm	P=70bar	X	CHUB36	CHUB22	CHESL06	CHTAER20ZC

TAKISAWA
MOD: TCY160/200

MODULO MOTORIZZATO ORIENTABILE +/-90° CON NONIO DIGITALE H=70mm
 +/-90° adjustable angle driven tool with digital display H=70mm
 Angetriebenes Werkzeug schwenkbar +/-90° mit digital display H=70mm

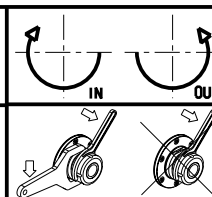

M.T. srl

Via Casino Albini 480
 Tel. 0541/956034-957884
 Fax 0541/956341
 47842 S. GIOVANNI IN M. (RN)
 e-mail: mtma@mtmarchetti.com
 http://www.mtmarchetti.com

PRODUZIONE MODULI ROTANTI



PAGINA TKW 335-1-01

Subject to change without notice.

10/2018

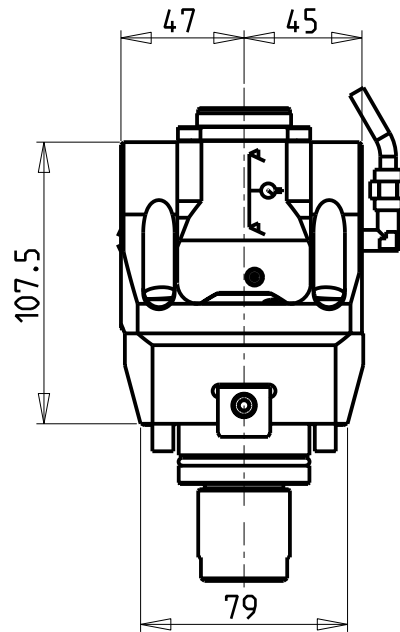
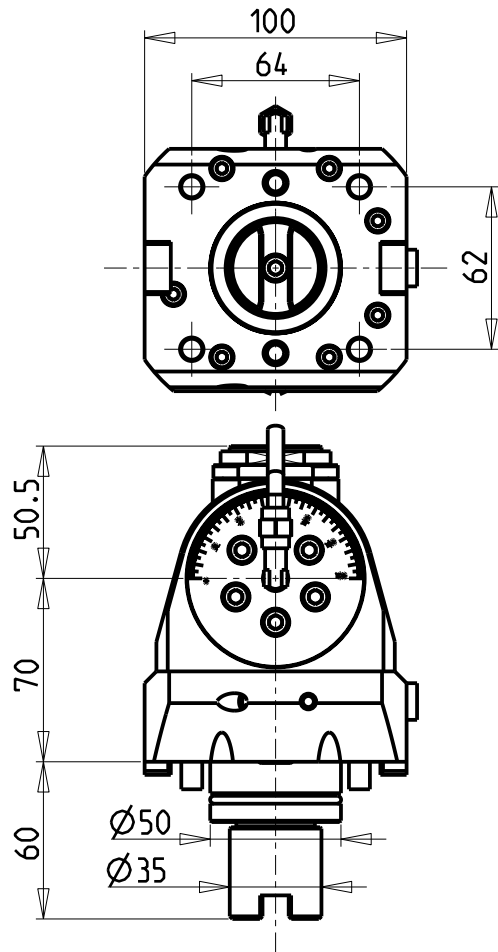

ATTENZIONE - ATTENTION - ACHTUNG

- Per lo smontaggio degli utensili utilizzare sempre la chiave di contrasto come indicato nel manuale d'uso.
- For disassembly of the tools use always the contrast key as mentioned in the user instructions.
- Fuer das Abmontieren der Werkzeuge immer den Gegenschlüssel benutzen wie in der Bedienungsanleitung erwäehnt.

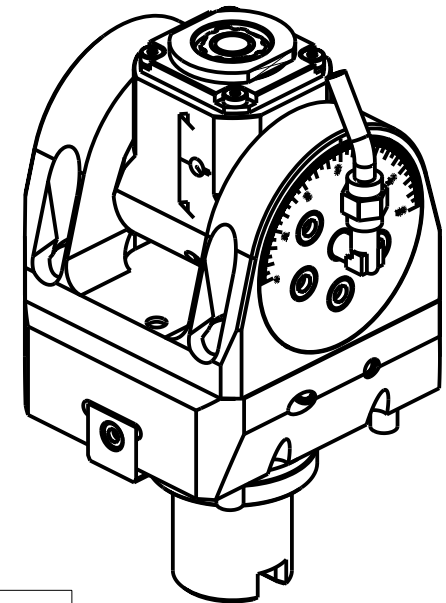

Cod. MT	Mandrino Spindle Spindel	I	RPM	Coppia Max Max Torque Max Drehmoment	Lubrificazione int. Coolant through Innenkuehlung	Lubrificazione est. Ext. coolant Aussenkuehlung	CHIAVI INCLUSE Keys included Schluessel inbegriffen			
							C HUB19_SP3	C HUB32	C HTAER16ZC	C HESL06
TKW 0500316	ERA16	1:2	12000	8Nm	-	X	C HUB19_SP3	C HUB32	C HTAER16ZC	C HESL06
TKW 0500416	ERA16	1:2	12000	8Nm	P=70bar	X	C HUB19_SP3	C HUB32	C HTAER16ZC	C HESL06

TAKISAWA
MOD: TCY160/200

MODULO MOTORIZZATO ORIENTABILE +/-90° MOLTIPLICATO I=1:2 H=70mm
 +/-90° adjustable angle driven tool geared-up I=1:2 H=70mm
 Angetriebenes Werkzeug schwenkbar +/-90° uebersetzt I=1:2 H=70mm

Subject to change without notice.

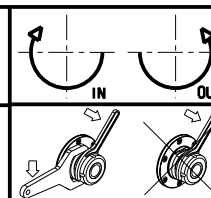

M.T. srl
 Via Casino Albini 480
 Tel. 0541/956034-957884
 Fax 0541/956341
 47842 S. GIOVANNI IN M. (RN)
 e-mail: mtma@mtmarchetti.com
 http://www.mtmarchetti.com

PRODUZIONE MODULI ROTANTI



PAGINA TKW 336-1-00

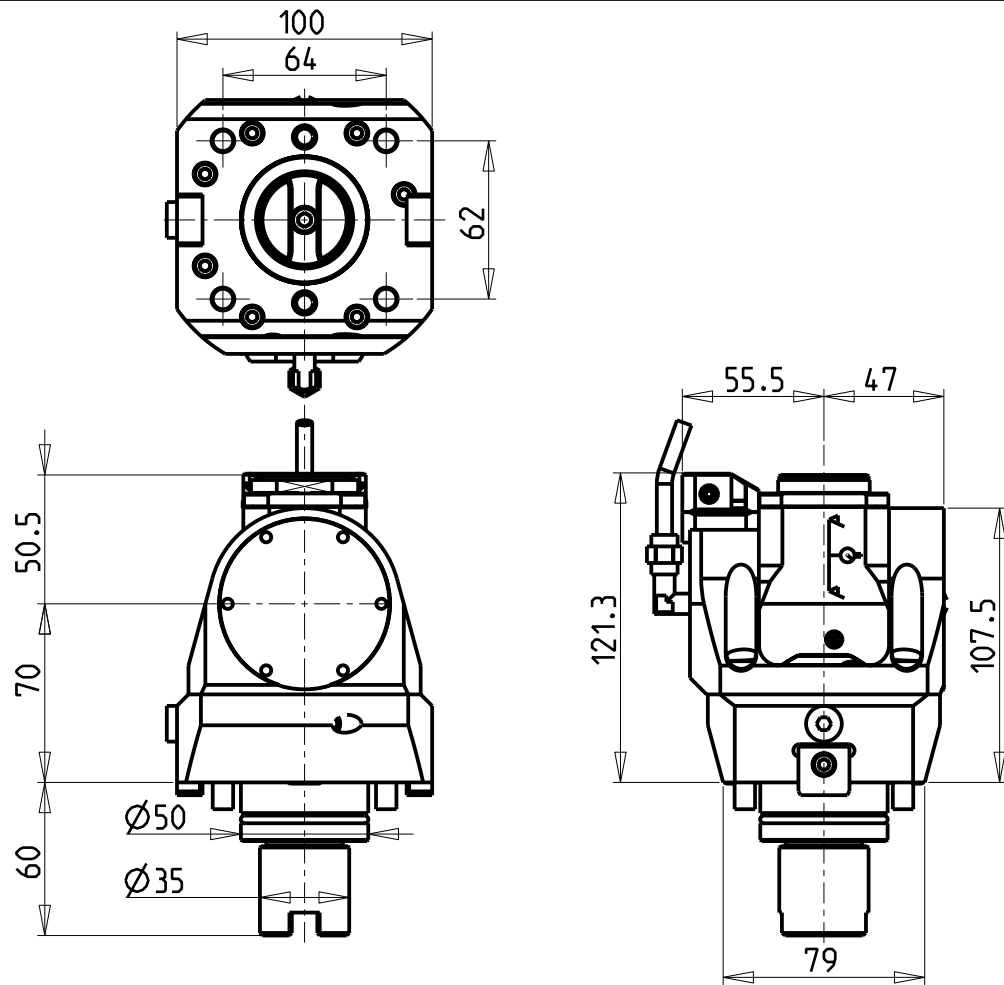

ATTENZIONE - ATTENTION - ACHTUNG

- Per lo smontaggio degli utensili utilizzare sempre la chiave di contrasto come indicato nel manuale d'uso.
- For disassembly of the tools use always the contrast key as mentioned in the user instructions.
- Fuer das Abmontieren der Werkzeuge immer den Gegenschlüssel benutzen wie in der Bedienungsanleitung erwäehnt.

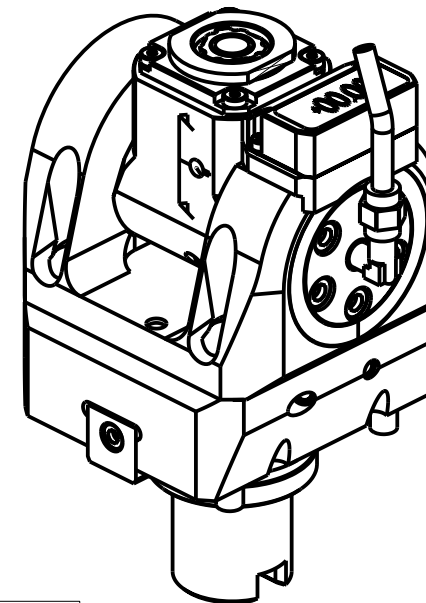

Cod. MT	Mandrino Spindle Spindel	I	RPM	Coppia Max Max Torque Max Drehmoment	Lubrificazione int. Coolant through Innenkuehlung	Lubrificazione est. Ext. coolant Aussenkuehlung	CHIAVI INCLUSE Keys included Schluessel inbegriffen			
TKW 0505316	ERA16	1:2	12000	8Nm	-	X	CHUB19_SP3	CHUB32	CHTAER16ZC	CHESL06
TKW 0505416	ERA16	1:2	12000	8Nm	P=70bar	X	CHUB19_SP3	CHUB32	CHTAER16ZC	CHESL06

TAKISAWA
MOD: TCY160/200

MODULO MOTORIZZATO ORIENTABILE +/-90° MOLTIPLICATO I=1:2 CON NONIO DIGITALE H=70mm
 +/-90° adjustable angle driven tool geared-up I=1:2 with digital display H=70mm
 Angetriebenes Werkzeug schwenkbar +/-90° uebersetzt I=1:2 mit digital display H=70mm

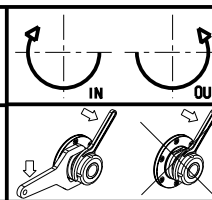

M.T. srl
 Via Casino Albini 480
 Tel. 0541/956034-957884
 Fax 0541/956341
 47842 S. GIOVANNI IN M. (RN)
 e-mail: mtma@mtmarchetti.com
 http://www.mtmarchetti.com

PRODUZIONE MODULI ROTANTI



PAGINA TKW 336-1-01

Subject to change without notice.

10/2018

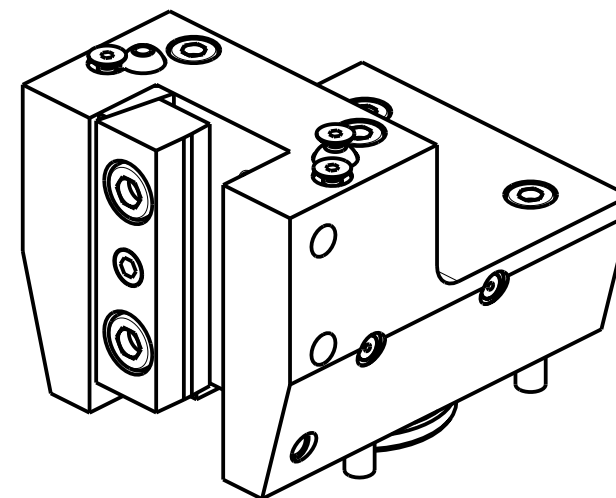
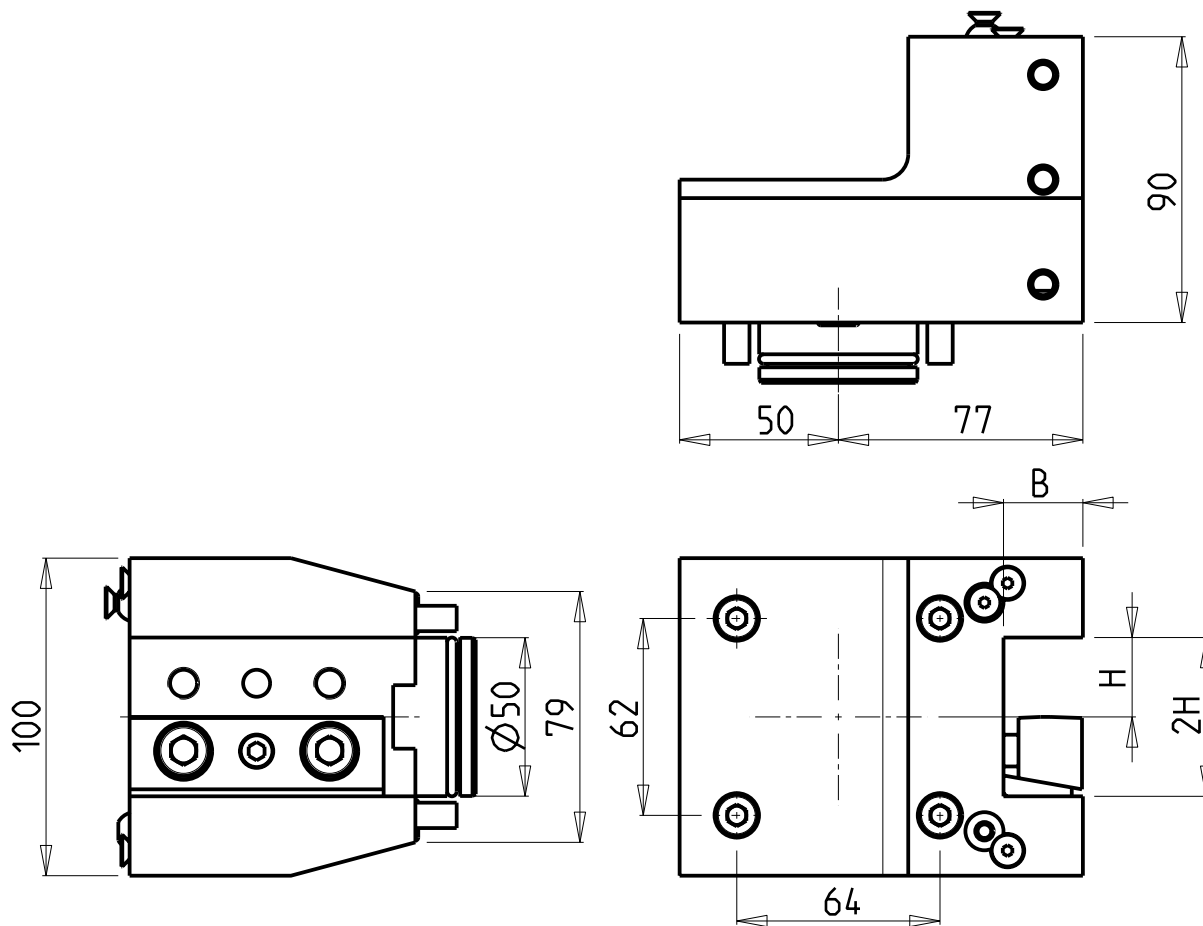

Cod. MT	Cod. TAKISAWA	N°Utensili N° Tools N° Werkzeuge	Reversibile lato mandrino/contromandrino Reversible sub/main spindle side Umkehrbare Spindel-seite/ Gegenspindel-seite	Misure Dimensions Masse	B	H
TKW 0042500	XL22027_001	1/2	X	mm	25	25

TAKISAWA
 MOD: TCY160/200
 PORTAUTENSILE RADIALE SINGOLO QD=25mm
 Radial single static tool QD=25mm
 Radial Single-Werkzeughalter QD=25mm

Subject to change without notice.

M.T. srl
 Via Casino Albini 480
 Tel. 0541/956034-957884
 Fax 0541/956341
 47842 S. GIOVANNI IN M. (RN)
 e-mail: mtma@mtmarchetti.com
 http://www.mtmarchetti.com

PRODUZIONE MODULI ROTANTI



PAGINA TKW 423-1-00

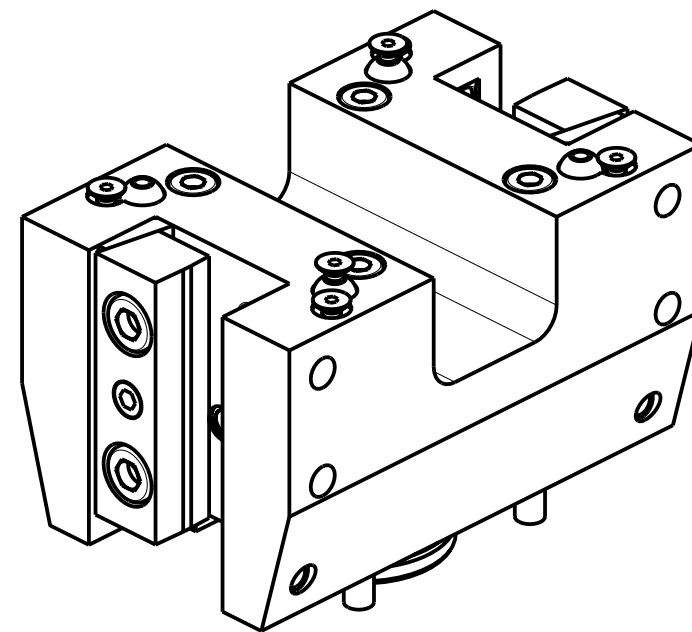
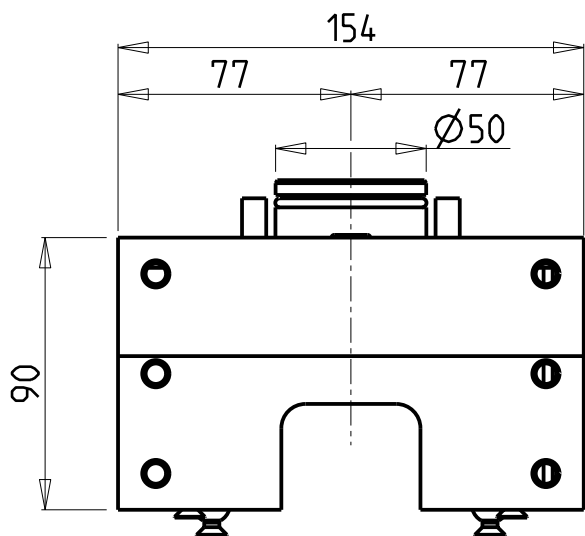
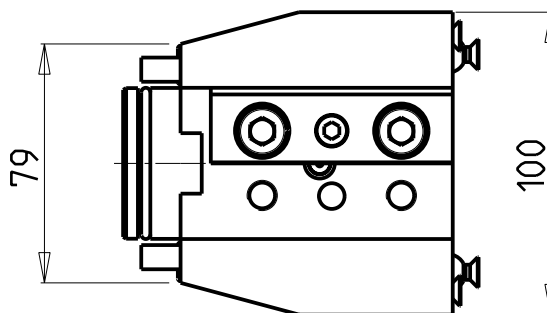
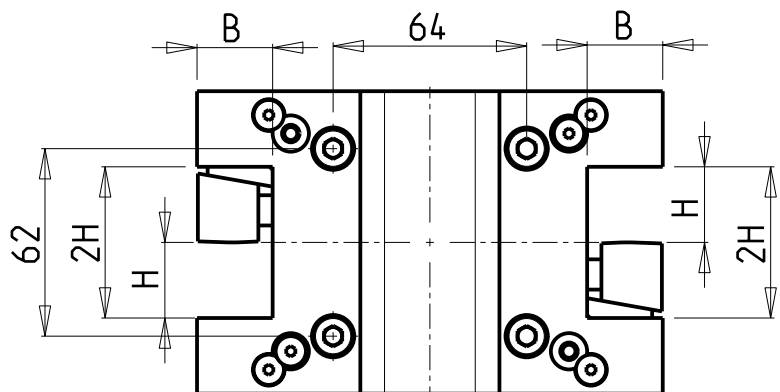

Cod. MT	Cod. TAKISAWA	N°Utensili N°Tools N°Werkzeuge	Reversibile lato mandrino/contromandrino Reversible sub/main spindle side Umkehrbare Spindelseite/ Gegenspindelseite	Misure Dimensions Masse	B	H
TKW 0082500	XL22030_001	2/4	X	mm	25	25

TAKISAWA

MOD: TCY160/200

PORTAUTENSILE RADIALE DOPPIO QD=25mm

Radial double static tool QD=25mm

Radial Doppel-Werkzeughalter QD=25mm

Subject to change without notice.



M.T. srl
Via Casino Albini 480
Tel. 0541/956034-957884
Fax 0541/956341
47842 S. GIOVANNI IN M. (RN)
e-mail: mtma@mtmarchetti.com
<http://www.mtmarchetti.com>

PRODUZIONE MODULI ROTANTI



PAGINA TKW 453-1-00

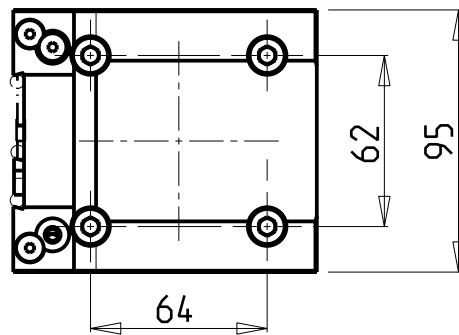
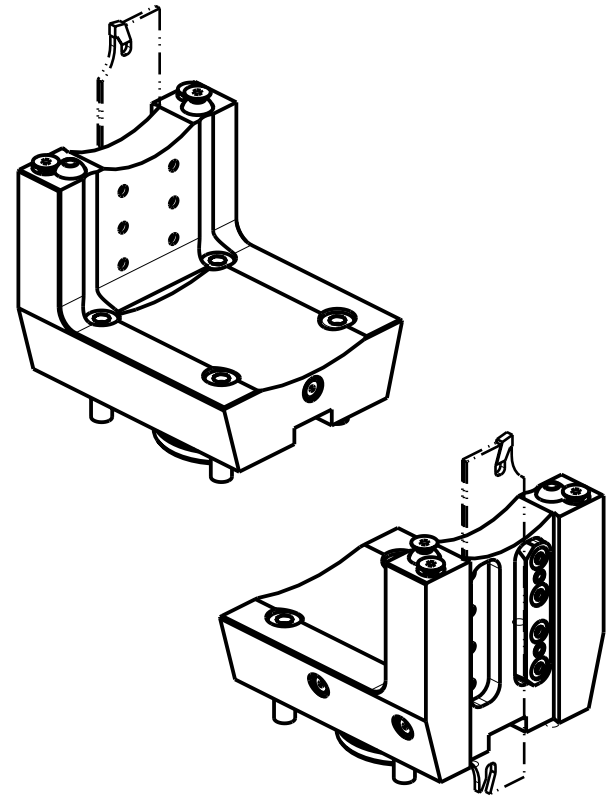
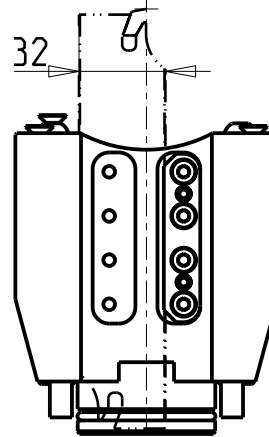
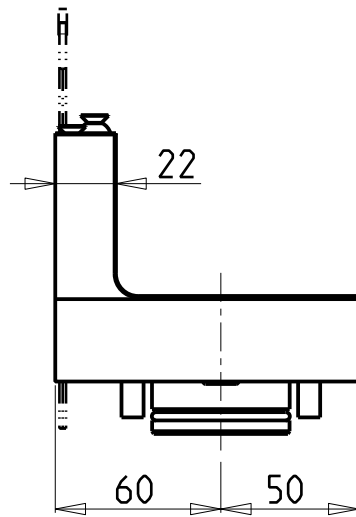
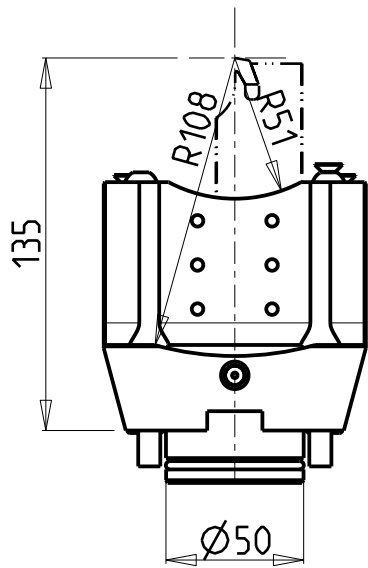

DOTAZIONI - SUPPLIED WITH - AUSSTATTUNG

N°1 - LAMA - BLADE - KLINGE ISCAR H-32 Sp. 3/4mm
(KENNAMETAL OPTIONAL)

N°10 - INSERTI - INSERTS - EINLAGEN

N°1 - CHIAVE A T PER MONTAGGIO INSERTI
- T-WRENCH FOR INSERT SET UP
- T-SCHLUESSEL FUER EINSATZSTUECK-MONTAGE

Cod. MT	Cod. TAKISAWA	N°Utensili N°Tools N°Werkzeuge	Lubr.esterna Ext. coolant Aussenkuehlung	Reversibile lato mandrino/contromandrino Reversible sub/main spindle side Umkehrbare Spindel-seite/ Gegenspindel-seite
TKW0070232	XL22037_001	1	X	X

TAKISAWA
MOD: TCY160/200
PORTAUTENSILE RADIALE PER LAMA
Radial blade holder
Radial Abstechhalter

M.T. srl
Via Casino Albini 480
Tel. 0541/956034-957884
Fax 0541/956341
47842 S. GIOVANNI IN M. (RN)
e-mail: mtma@mtmarchetti.com
http://www.mtmarchetti.com

PRODUZIONE MODULI ROTANTI



PAGINA TKW510-1-00

Subject to change without notice.

10/2018

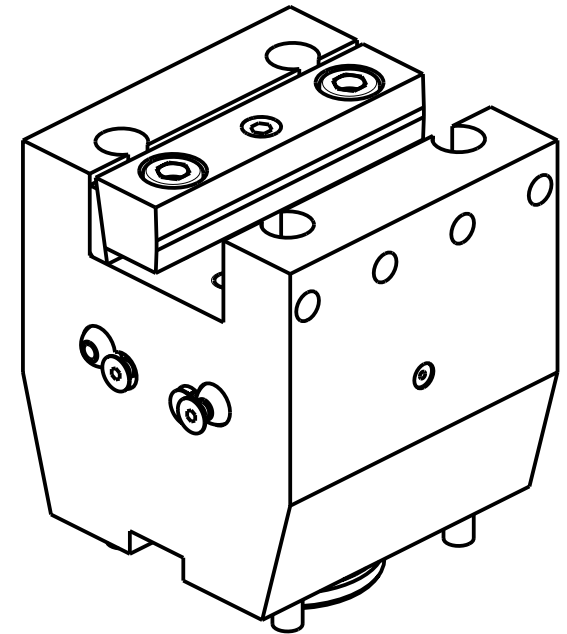
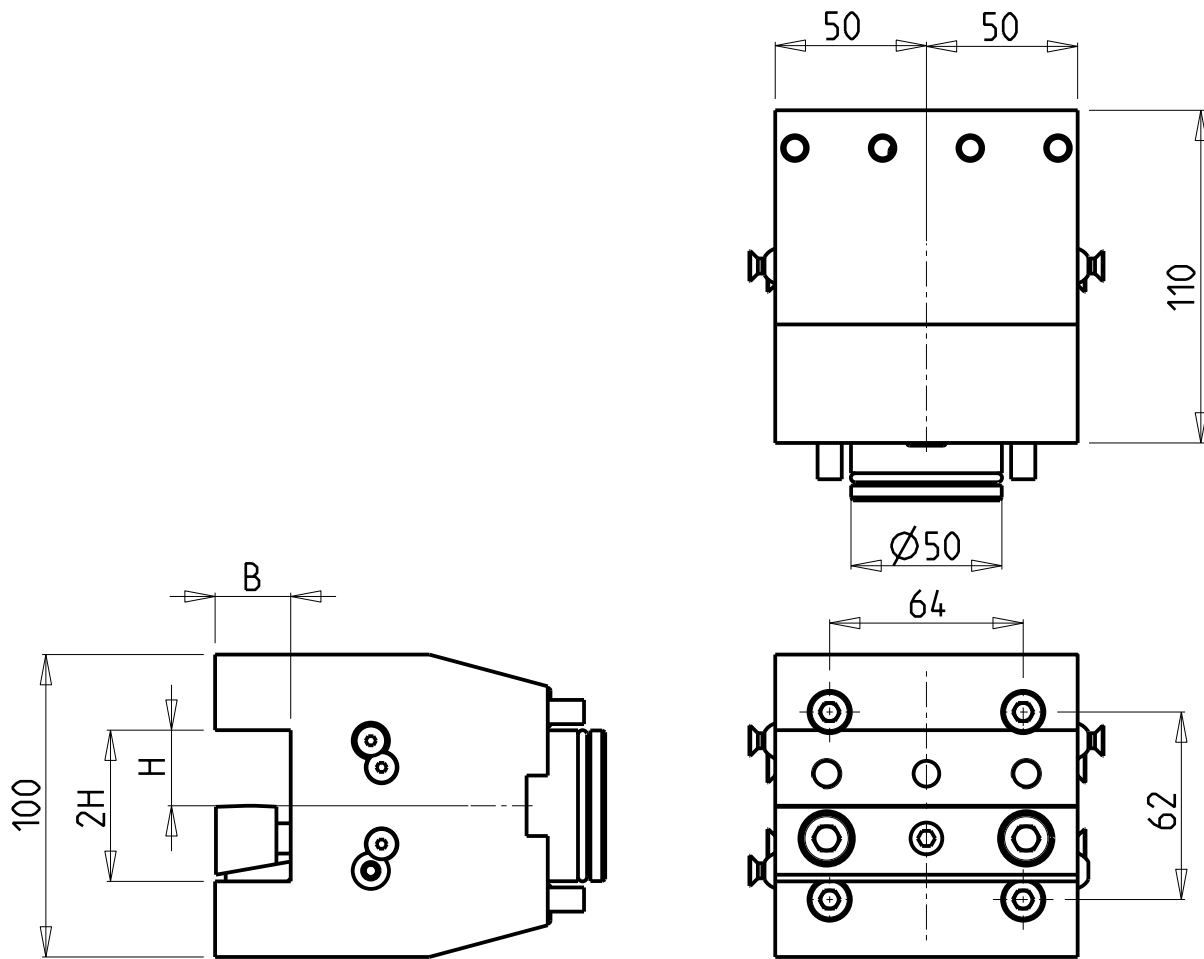

Cod. MT	Cod. TAKISAWA	N°Utensili N°Tools N°Werkzeuge	Reversibile lato mandrino/contromandrino Reversible sub/main spindle side Umkehrbare Spindelseite/ Gegenspindelseite	Misure Dimensions Masse	B	H
TKW 0052500	XL22029_001	1/2	X	mm	25	25

TAKISAWA
 MOD: TCY160/200
 PORTAUTENSILE ASSIALE SINGOLO QD=25mm
 Axial single static tool QD=25mm
 Axial Single-Werkzeughalter QD=25mm

Subject to change without notice.

M.T. srl
 Via Casino Albini 480
 Tel. 0541/956034-957884
 Fax 0541/956341
 47842 S. GIOVANNI IN M. (RN)
 e-mail: mtma@mtmarchetti.com
 http://www.mtmarchetti.com

PRODUZIONE MODULI ROTANTI



PAGINA TKW552-1-00

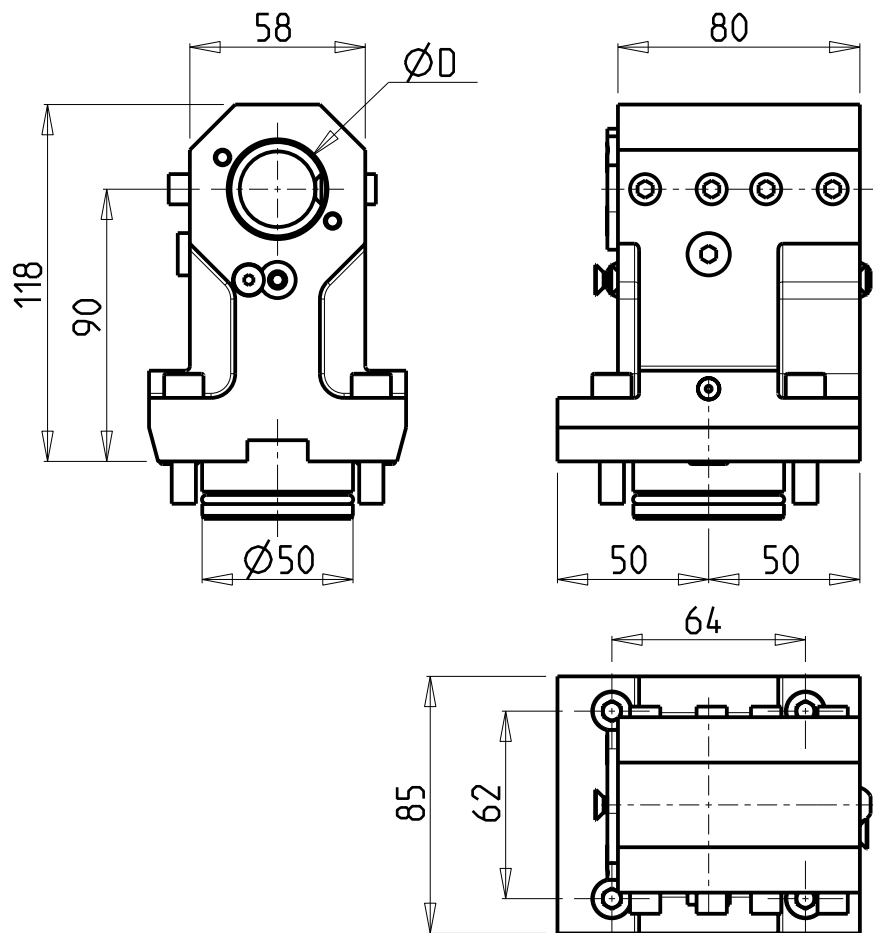

KIT ADDUZIONE INTERNA (OPZIONALE)
 KIT FOR INTERNAL COOLANT (OPTIONAL)
 KIT FUER INTERNE KUEHLMITTELZUFUHR (OPTIONAL)
 Ø32 cod. KIT1000001

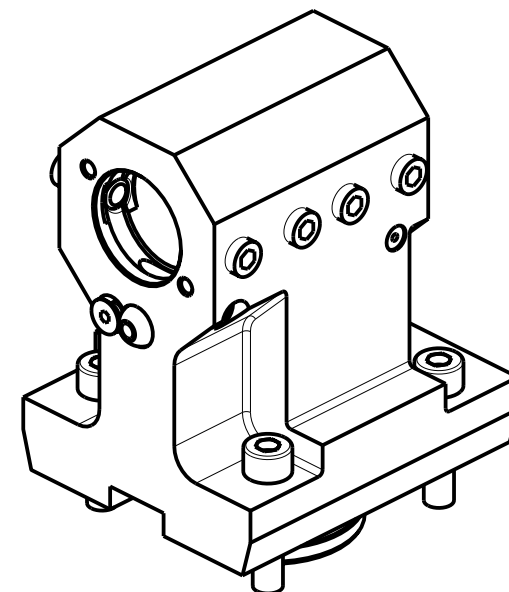
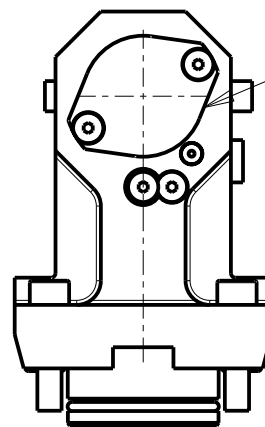

PER BOCCOLE DI RIDUZIONE VEDI PAG. TBL150-1-00
 FOR REDUCING BUSHINGS SEE PAGE TBL150-1-00
 FUER REDUZIERBUCHSE SIEHE SEITE TBL150-1-00

Cod. MT	Cod. TAKISAWA	N°Utensili N°Tools N°Werkzeuge	Lubrificazione int. opzionale Coolant through optional Innenkuehlung Optional	Lubrificazione est. Ext. coolant Aussenkuehlung	Misure Dimensions Masse	D
TKW0063200	XL22032_001 / XL22034_001	1	X	X	mm	32

TAKISAWA
 MOD: TCY160/200
 PORTAUTENSILE ASSIALE PER BARENO Ø32mm H=90mm
 Axial single boring bar holder Ø32mm H=90mm
 Axial Bohrhalter Ø32mm H=90mm

Subject to change without notice.

M.T. srl
 Via Casino Albini 480
 Tel. 0541/956034-957884
 Fax 0541/956341
 47842 S. GIOVANNI IN M. (RN)
 e-mail: mtma@mtmarchetti.com
 http://www.mtmarchetti.com

PRODUZIONE MODULI ROTANTI



PAGINA TKW660-1-10

