

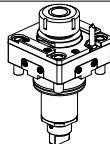

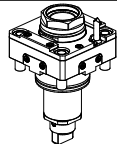

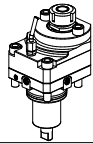

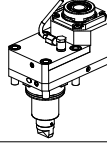

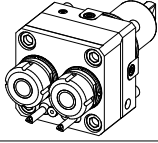
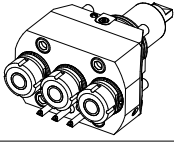
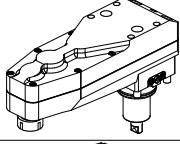

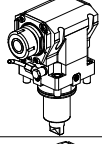
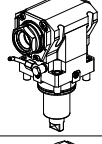
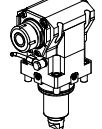
		PAGINA Page Seite
<b>MODULO MOTORIZZATO RADIALE MAGGIORATO</b> Radial reinforced driven tool Radial angetriebenes Werkzeug vergrößert		SPN020.2.01
<b>MODULO MOTORIZZATO RADIALE MAGGIORATO MTSK</b> Radial MTSK reinforced driven tool Radial MTSK angetriebenes Werkzeug vergrößert		SPN020.2.01.K
<b>MODULO MOTORIZZATO RADIALE MOLTIPLICATO 1=1:2 DISASSATO IN Z 36mm</b> Radial geared-up 1=1:2 driven tool re-directed in Z by 36mm Radial angetriebenes Werkzeug uebersetzt 1=1:2 achsversetzt in Z um 36mm		SPN030.2.30
<b>MODULO MOTORIZZATO RADIALE RIDOTTO 1=2:1 DISASSATO IN Z 80mm</b> Radial geared-down 1=2:1 driven tool re-directed in Z by 80mm Radial angetriebenes Werkzeug untersetzt 1=2:1 achsversetzt in Z um 80mm		SPN033.2.20
<b>MODULO MOTORIZZATO RADIALE 2 USCITE IN Y</b> Radial single side twin head driven tool in Y Radial angetriebenes Werkzeug 2 Ausgaenge in Y		SPN080.2.00
<b>MODULO MOTORIZZATO RADIALE 3 USCITE IN Y</b> Radial single side 3 outlet driven tool in Y Radial angetriebenes Werkzeug 3 Ausgaenge in Y		SPN095.2.00
<b>MODULO MOTORIZZATO RADIALE ROVESCIATO DISASSATO IN Z 250mm</b> Radial inverted driven tool re-directed in Z by 250mm Radial angetriebenes Werkzeug ungekehrt achsversetzt in Z um 250mm		SPN120.2.10
<b>MODULO MOTORIZZATO ASSIALE H=72mm</b> Axial driven tool H=72mm Axial angetriebenes Werkzeug H=72mm		SPN150.2.11
<b>MODULO MOTORIZZATO ASSIALE MTSK H=72mm</b> Axial MTSK driven tool H=72mm Axial MTSK angetriebenes Werkzeug H=72mm		SPN150.2.11.K
<b>MODULO MOTORIZZATO ASSIALE H=85mm</b> Axial driven tool H=85mm Axial angetriebenes Werkzeug H=85mm		SPN150.2.15
<b>MODULO MOTORIZZATO ASSIALE MTSK H=85mm</b> Axial MTSK driven tool H=85mm Axial MTSK angetriebenes Werkzeug H=85mm		SPN150.2.15.K
<b>MODULO MOTORIZZATO ASSIALE H=95mm</b> Axial driven tool H=95mm Axial angetriebenes Werkzeug H=95mm		SPN150.2.18

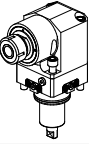

		PAGINA Page Seite
<b>MODULO MOTORIZZATO ASSIALE MTSK H=95mm</b> Axial MTSK driven tool H=95mm Axial MTSK angetriebenes Werkzeug H=95mm		SPN150.2.18.K
<b>MODULO MOTORIZZATO ASSIALE H=100mm</b> Axial driven tool H=100mm Axial angetriebenes Werkzeug H=100mm		SPN150.2.20
<b>MODULO MOTORIZZATO ASSIALE H=100mm</b> Axial driven tool H=100mm Axial angetriebenes Werkzeug H=100mm		SPN150.2.21
<b>MODULO MOTORIZZATO ASSIALE MTSK H=100mm</b> Axial MTSK driven tool H=100mm Axial MTSK angetriebenes Werkzeug H=100mm		SPN150.2.21.K
<b>MODULO MOTORIZZATO ASSIALE MAGGIORATO H=72mm</b> Axial reinforced driven tool H=72mm Axial angetriebenes Werkzeug vergrößert H=72mm		SPN170.2.10
<b>MODULO MOTORIZZATO ASSIALE MAGGIORATO MTSK H=72mm</b> Axial MTSK reinforced driven tool H=72mm Axial MTSK angetriebenes Werkzeug vergrößert H=72mm		SPN170.2.10.K
<b>MODULO MOTORIZZATO ASSIALE MAGGIORATO H=85mm</b> Axial reinforced driven tool H=85mm Axial angetriebenes Werkzeug vergrößert H=85mm		SPN170.2.20
<b>MODULO MOTORIZZATO ASSIALE MAGGIORATO MTSK H=85mm</b> Axial MTSK reinforced driven tool H=85mm Axial MTSK angetriebenes Werkzeug vergrößert H=85mm		SPN170.2.20.K
<b>MODULO MOTORIZZATO ASSIALE MAGGIORATO H=95mm</b> Axial reinforced driven tool H=95mm Axial angetriebenes Werkzeug vergrößert H=95mm		SPN170.2.25
<b>MODULO MOTORIZZATO ASSIALE MAGGIORATO MTSK H=95mm</b> Axial MTSK reinforced driven tool H=95mm Axial MTSK angetriebenes Werkzeug vergrößert H=95mm		SPN170.2.25.K
<b>MODULO MOTORIZZATO ASSIALE MAGGIORATO H=100mm</b> Axial reinforced driven tool H=100mm Axial angetriebenes Werkzeug vergrößert H=100mm		SPN170.2.30
<b>MODULO MOTORIZZATO ASSIALE MAGGIORATO MTSK H=100mm</b> Axial MTSK reinforced driven tool H=100mm Axial MTSK angetriebenes Werkzeug vergrößert H=100mm		SPN170.2.30.K

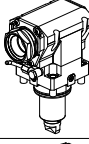
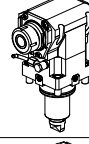
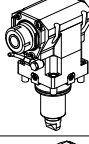
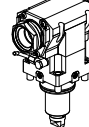
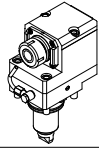
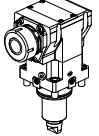
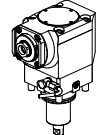
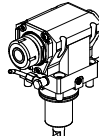
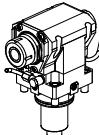
		PAGINA Page Seite
<p><b>MODULO MOTORIZZATO ASSIALE ARRETRATO H=95mm</b> Axial rear-set driven tool H=95mm Axial angetriebenes Werkzeug zurueckversetzt H=95mm</p>		<p>SPN180.2.25</p> <p>NEW</p>
<p><b>MODULO MOTORIZZATO ASSIALE RIDOTTO I=2:1 H=100mm</b> Axial geared-down I=2:1 driven tool H=100mm Axial angetriebenes Werkzeug untersetzt I=2:1 H=100mm</p>		SPN190.2.30
<p><b>MODULO MOTORIZZATO ASSIALE MOLTIPLICATO I=1:2</b> Axial geared-up I=1:2 driven tool Axial angetriebenes Werkzeug uebersetzt I=1:2</p>		SPN200.2.20
<p><b>MODULO MOTORIZZATO ASSIALE BISPORGENTE H=72mm</b> Axial opposite face driven tool H=72mm Axial angetriebenes Werkzeug halb vorspringend H=72mm</p>		SPN240.2.10
<p><b>MODULO MOTORIZZATO ASSIALE BISPORGENTE H=85mm</b> Axial opposite face driven tool H=85mm Axial angetriebenes Werkzeug halb vorspringend H=85mm</p>		SPN240.2.15
<p><b>MODULO MOTORIZZATO ASSIALE BISPORGENTE H=95mm</b> Axial opposite face driven tool H=95mm Axial angetriebenes Werkzeug halb vorspringend H=95mm</p>		SPN240.2.18
<p><b>MODULO MOTORIZZATO ASSIALE BISPORGENTE H=100mm</b> Axial opposite face twin driven tool H=100mm Axial angetriebenes Werkzeug halb vorspringend H=100mm</p>		SPN240.2.20
<p><b>MODULO MOTORIZZATO ASSIALE BISPORGENTE H=100mm</b> Axial opposite face driven tool H=100mm Axial angetriebenes Werkzeug halb vorspringend H=100mm</p>		SPN240.2.21
<p><b>MODULO MOTORIZZATO ASSIALE 2 USCITE IN Y H=100mm</b> Axial single side twin head driven tool in Y H=100mm Axial angetriebenes Werkzeug 2 Ausgaenge in Y H=100mm</p>		SPN260.2.30
<p><b>MODULO MOTORIZZATO ORIENTABILE ±90° H=54mm</b> ±90° adjustable angle driven tool H=54mm Angetriebenes Werkzeug schwenkbar ±90° H=54mm</p>		SPN333.2.00
<p><b>MODULO MOTORIZZ. ORIENTABILE ±90° CON NONIO DIGITALE H=54mm</b> ±90° adjustable angle driven tool with digital display H=54mm Angetriebenes Werkzeug schwenkbar ±90° mit digital display H=54mm</p>		SPN333.2.01
<p><b>MODULO MOTORIZZATO ORIENTABILE ±90° H=100mm</b> ±90° adjustable angle driven tool H=100mm Angetriebenes Werkzeug schwenkbar ±90° H=100mm</p>		SPN333.2.10

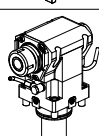
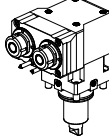
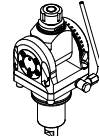
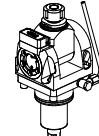
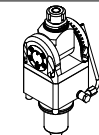
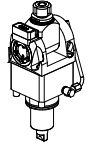
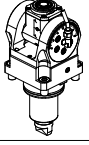
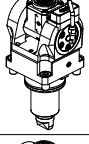
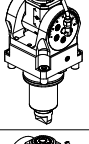
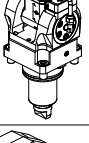
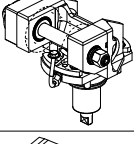
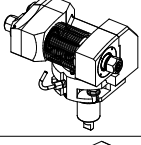
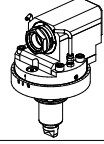
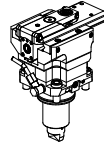
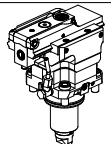
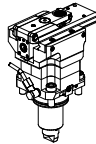
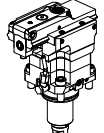
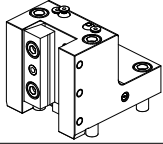
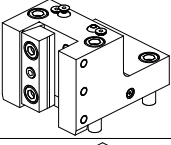
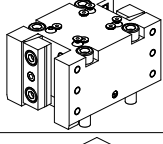
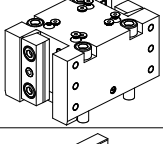
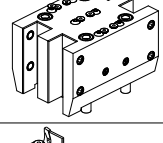
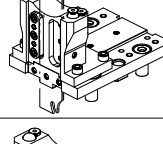
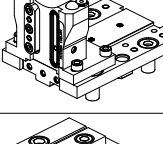
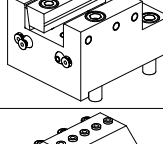
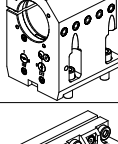
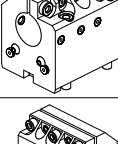
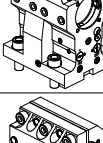
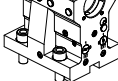
		PAGINA Page Seite
<p><b>MODULO MOTORIZZ ORIENTABILE <math>\pm 90^\circ</math> CON NONIO DIGITALE H=100mm</b>  <math>\pm 90^\circ</math> adjustable angle driven tool with digital display H=100mm  Angetriebenes Werkzeug schwenkbar <math>\pm 90^\circ</math> mit digital display H=100mm</p>		SPN333.2.11
<p><b>MODULO MOTORIZZATO ORIENTABILE <math>\pm 90^\circ</math> H=72mm</b>  <math>\pm 90^\circ</math> adjustable angle driven tool H=72mm  Angetriebenes Werkzeug schwenkbar <math>\pm 90^\circ</math> H=72mm</p>		SPN335.2.00
<p><b>MODULO MOTORIZZ ORIENTABILE <math>\pm 90^\circ</math> CON NONIO DIGITALE H=72mm</b>  <math>\pm 90^\circ</math> adjustable angle driven tool with digital display H=72mm  Angetriebenes Werkzeug schwenkbar <math>\pm 90^\circ</math> mit digital display H=72mm</p>		SPN335.2.01
<p><b>MODULO MOTORIZZATO ORIENTABILE <math>\pm 90^\circ</math> MOLTIPLICATO I=1:2 H=72mm</b>  <math>\pm 90^\circ</math> adjustable angle driven tool geared-up I=1:2 H=72mm  Angetriebenes Werkzeug schwenkbar <math>\pm 90^\circ</math> uebersetzt I=1:2 H=72mm</p>		SPN336.2.00
<p><b>MOD. MOT. ORIENTABILE <math>\pm 90^\circ</math> MOLTIPL. I=1:2 CON NONIO DIGIT. H=72mm</b>  <math>\pm 90^\circ</math> adjustable angle driven tool geared-up I=1:2 with digital display H=72mm  Angetr. Werkzeug schwenkbar <math>\pm 90^\circ</math> uebersetzt I=1:2 mit digital display H=72mm</p>		SPN336.2.01
<p><b>MODULO MOTORIZZATO PORTACREATORE</b>  Driven gear hobber  Angetriebenes Zahnradwaelzfraes-Werkzeug</p>		SPN340.2.00
<p><b>MODULO MOTORIZZATO PORTACREATORE MAGGIORATO</b>  Reinforced driven gear hobber  Angetriebenes Zahnradwaelzfraes-Werkzeug vergroessert</p>		SPN340.2.60
<p><b>MODULO MOTORIZZATO ASSIALE MTSK PER POWER SKIVING H=100mm</b>  Axial MTSK driven tool for Power Skiving H=100mm  Axial MTSK angetriebenes Werkzeug fuer Power Skiving H=100mm</p>		SPN350.2.00.K
<p><b>MODULO MOTORIZZATO STOZZATORE CORSA 50mm H=85mm</b>  Slotting driven tool 50mm stroke H=85mm  Keilnutenstossmaschine 50mm Hub H=85mm</p>		SPN360.2.00
<p><b>MODULO MOTORIZZATO STOZZATORE CORSA 25mm H=85mm</b>  Slotting driven tool 25mm stroke H=85mm  Keilnutenstossmaschine 25mm Hub H=85mm</p>		SPN360.2.01
<p><b>MODULO MOTORIZZATO STOZZATORE CORSA 50mm H=100mm</b>  Slotting driven tool 50mm stroke H=100mm  Keilnutenstossmaschine 50mm Hub H=100mm</p>		SPN360.2.10
<p><b>MODULO MOTORIZZATO STOZZATORE CORSA 25mm H=100mm</b>  Slotting driven tool 25mm stroke H=100mm  Keilnutenstossmaschine 25mm Hub H=100mm</p>		SPN360.2.11

		PAGINA Page Seite
<p><b>PORTAUTENSILE RADIALE SINGOLO QD=25mm / QD=1" H=90mm</b> Radial single static tool QD=25mm / QD=1" H=90mm Radial Single-Werkzeughalter QD=25mm / QD=1" H=90mm</p>		SPN423.2.00
<p><b>PORTAUTENSILE RADIALE SINGOLO QD=25mm / QD=1" H=75mm</b> Radial single static tool QD=25mm / QD=1" H=75mm Radial Single-Werkzeughalter QD=25mm / QD=1" H=75mm</p>		SPN423.2.10
<p><b>PORTAUTENSILE RADIALE DOPPIO QD=25mm / QD=1" H=90mm</b> Radial double static tool QD=25mm / QD=1" H=90mm Radial Doppel-Werkzeughalter QD=25mm / QD=1" H=90mm</p>		SPN453.2.00
<p><b>PORTAUTENSILE RADIALE DOPPIO QD=25mm H=75mm</b> Radial double static tool QD=25mm H=75mm Radial Doppel-Werkzeughalter QD=25mm H=75mm</p>		SPN453.2.10
<p><b>PORTAUTENSILE RADIALE DOPPIO SOVRAPPOSTO QD=25mm / QD=1"</b> Radial double side twin static tool QD=25mm / QD=1" Radial Doppel-Werkzeughalter ueberlagert QD=25mm / QD=1"</p>		SPN463.2.00
<p><b>PORTAUTENSILE RADIALE PER LAMA</b> Radial blade holder Radial Abstechhalter</p>		SPN520.2.01
<p><b>PORTAUTENSILE RADIALE PER LAMA CON LUBRIFICAZIONE INTERNA</b> Radial blade holder with internal coolant Radial Abstechhalter mit Innenkuehlung</p>		SPN520.2.05
<p><b>PORTAUTENSILE ASSIALE SINGOLO QD=25mm / QD=1"</b> Axial single static tool QD=25mm / QD=1" Axial Single-Werkzeughalter QD=25mm / QD=1"</p>		SPN552.2.00
<p><b>PORTAUTENSILE ASSIALE PER BARENO Ø60mm H=100mm</b> Axial single boring bar holder Ø60mm H=100mm Axial Bohrhalter Ø60mm H=100mm</p>		SPN590.2.20
<p><b>PORTAUTENSILE ASSIALE PER BARENO Ø40mm/Ø1 1/2"/Ø50mm/Ø2" H=72mm</b> Axial single boring bar holder Ø40mm/Ø1 1/2"/Ø50mm/Ø2" H=72mm Axial Bohrhalter Ø40mm/Ø1 1/2"/Ø50mm/Ø2" H=72mm</p>		SPN610.2.20
<p><b>PORTAUTENSILE ASSIALE PER BARENO Ø50mm H=100mm</b> Axial single boring bar holder Ø50mm H=100mm Axial Bohrhalter Ø50mm H=100mm</p>		SPN620.2.20
<p><b>PORTAUTENSILE ASSIALE PER BARENO Ø40mm H=100mm</b> Axial single boring bar holder Ø40mm H=100mm Axial Bohrhalter Ø40mm H=100mm</p>		SPN640.2.20

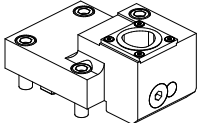
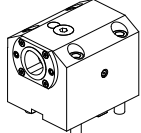
		PAGINA Page Seite
<p><b>PORTAUTENSILE ASSIALE PER BARENO Ø60mm H=100mm</b> Axial single boring bar holder Ø60mm H=100mm Axial Bohrhalter Ø60mm H=100mm</p>		SPN720.2.20
<p><b>PORTAUTENSILE ASSIALE PER BARENO 2 POSIZIONI Ø32mm</b> Axial double boring bar holder Ø32mm Axial Bohrhalter 2 Positionen Ø32mm</p>		SPN862.2.00
<p><b>CONTROPUNTA PER CONTROMANDRINO</b> Tailstock for subspindle Gegenspitz fuer Gegenspindel</p>		SPN950.2.00

<p><b>PORTAUTENSILE RADIALE SINGOLO ARRETRATO MT CAPTO</b> Radial single rear-set static tool MT CAPTO Radial Single-Werkzeughalter zurueckversetzt MT CAPTO</p>		SPN430.B.40
<p><b>PORTAUTENSILE ASSIALE SINGOLO MT CAPTO</b> Axial single static tool MT CAPTO Axial Single-Werkzeughalter MT CAPTO</p>		SPN550.B.40 

## CUSCINETTI MAGGIORATI PER LAVORAZIONI PESANTI

Reinforced bearings for  
heavy machining

Vergroesserte Lager fuer  
schwerere Bearbeitungen

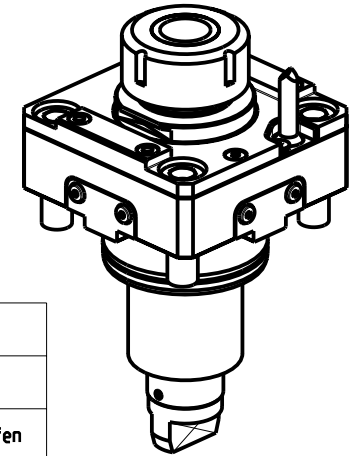
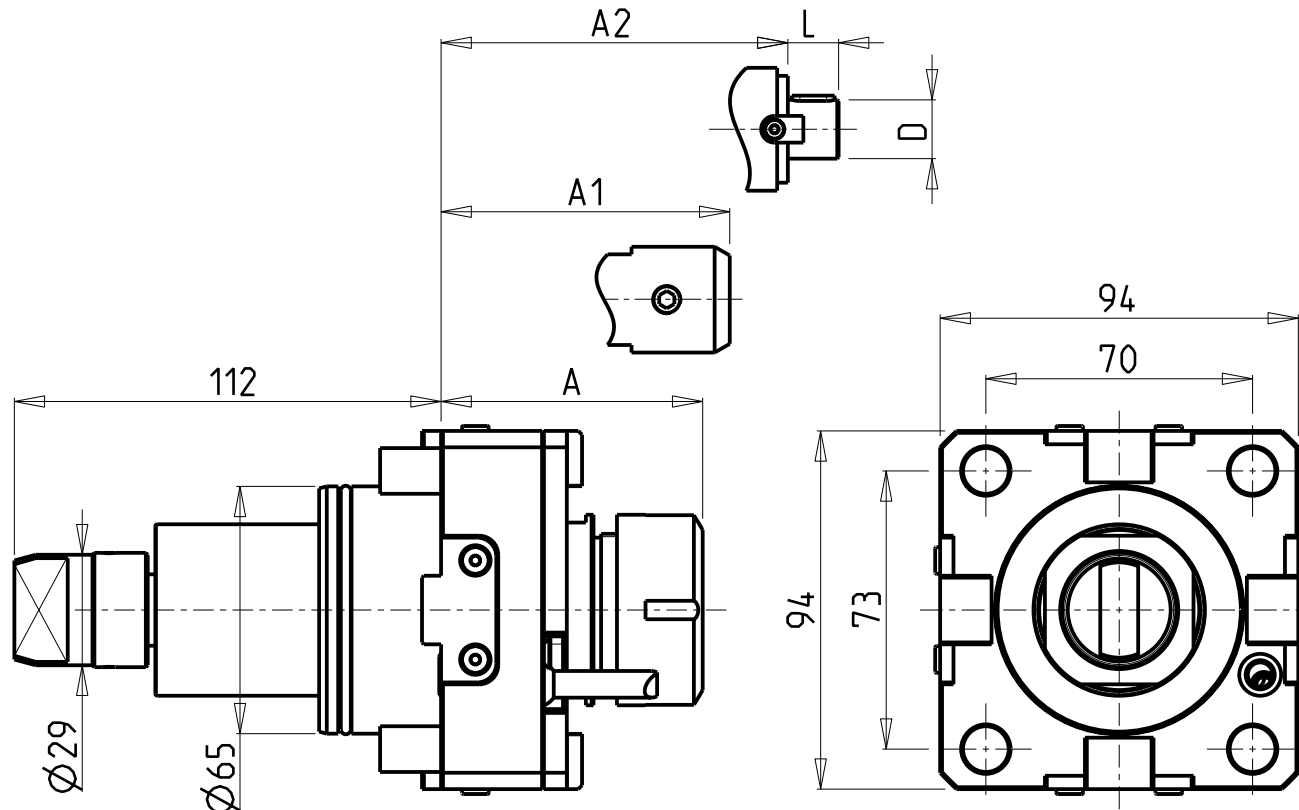

- Chiave inclusa
- Key included
- Schluessel inbegriffen

Cod. MT	Mandrino Spindle Spindel	I	RPM	Coppia Max Max Torque Max Drehmoment	Lubrificazione int. Coolant through Innenkuehlung	Lubrificazione est. Ext. coolant Aussenkuehlung	A	A1	A2	D	L	CHIAVI NON INCLUSE Keys not included Schluessel nicht einbegriffen	
DW 01540132	ER32	1:1	6000	100Nm	-	X	68.7	-	-	-	-	CHSTER32	OKU0650004 ▪
DW 01540232	ER32	1:1	6000	100Nm	P=30bar	X	79.2	-	-	-	-	CHSTER32	OKU0650004 ▪
DW 01540140	ER40	1:1	6000	100Nm	-	X	71.7	-	-	-	-	CHSTER40	OKU0650004 ▪
DW 01540240	ER40	1:1	6000	100Nm	P=30bar	X	82.2	-	-	-	-	CHSTER40	OKU0650004 ▪
DW 01540625	WELDON 25	1:1	6000	100Nm	P=30bar	X	-	72.5	-	-	-	-	OKU0650004 ▪
DW 01540827	Ø27x21	1:1	6000	100Nm	P=30bar	X	-	-	56.5	27	21	CH_VTCROCE_M12 ▪	OKU0650004 ▪

SPINNER

MOD: TC800 SMCY (BMT65)

MODULO MOTORIZZATO RADIALE MAGGIORATO

Radial reinforced driven tool

Radial angetriebenes Werkzeug vergroessert

Subject to change without notice.

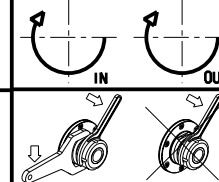

**M.T. srl**

Via Casino Albini 480  
Tel. 0541/956034-957884  
Fax 0541/956341  
47842 S. GIOVANNI IN M. (RN)  
e-mail: mtma@mtmarchetti.com  
http://www.mtmarchetti.com

PRODUZIONE MODULI ROTANTI



PAGINA SPN020-2-01

## CUSCINETTI MAGGIORATI PER LAVORAZIONI PESANTI

Reinforced bearings for  
heavy machining

Vergroesserte Lager fuer  
schwerere Bearbeitungen

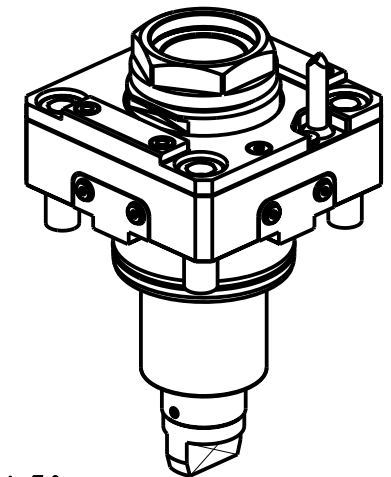
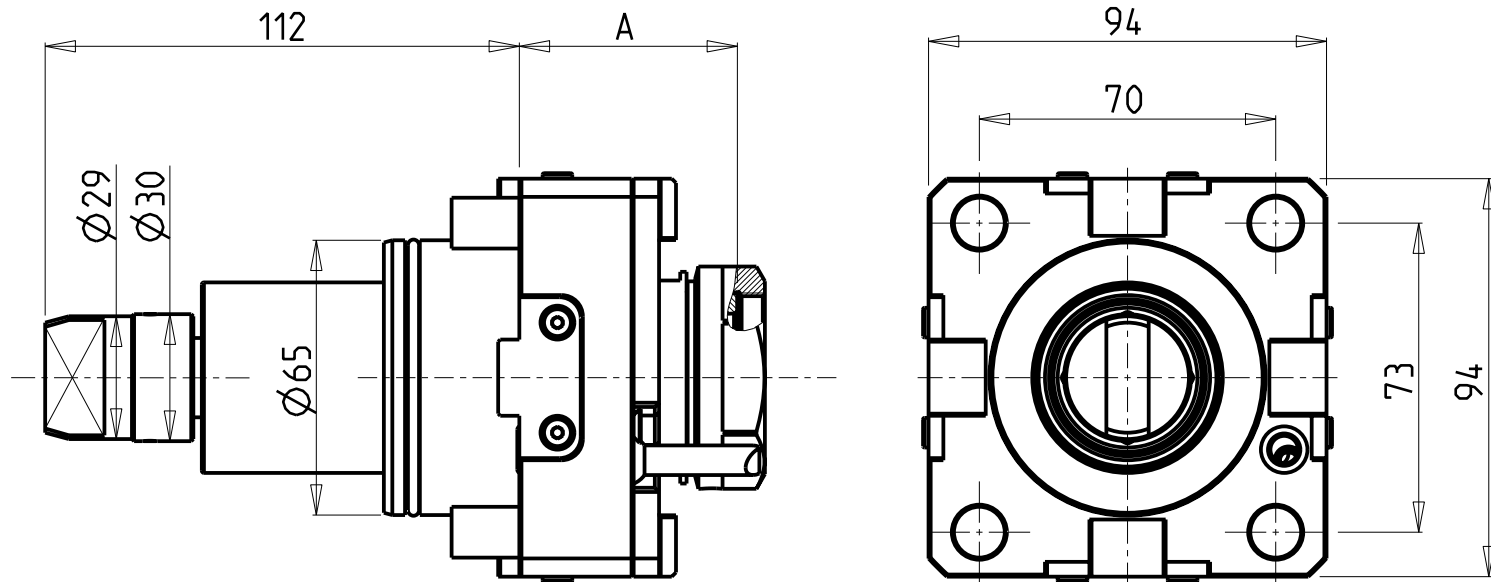

PER PORTAUTENSILI MODULARI MTSK-40 VEDI PAG. TBL300-1-40 E PER MTSK-50 VEDI PAG. TBL300-1-50  
FOR MTSK-40 QUICK CHANGE TOOLHOLDERS CLAMPINGS SEE PAGE TBL300-1-40 AND FOR MTSK-50 SEE PAGE TBL300-1-50  
FUER MTSK-40 MODULARE WERKZEUGAUFNAHMEN SIEHE SEITE TBL300-1-40 UND FUER MTSK-50 SIEHE SEITE TBL300-1-50

Cod. MT	Mandrino Spindle Spindel	I	RPM	Coppia Max Max Torque Max Drehmoment	Lubrificazione int. Coolant through Innenkuehlung	Lubrificazione est. Ext. coolant Aussenkuehlung	A	CHIAVI NON INCLUSE Keys not included Schlüssel nicht einbegriffen	
DW 01550140	MTSK-40	1:1	6000	100Nm	-	X	51.5	CHUB46	OKU0650004 ■
DW 01550240	MTSK-40	1:1	6000	100Nm	P=30bar	X	62.5	CHUB46	OKU0650004 ■
DW 01550150	MTSK-50	1:1	6000	100Nm	-	X	51.5	CHUB55	OKU0650004 ■
DW 01550250	MTSK-50	1:1	6000	100Nm	P=30bar	X	62.5	CHUB55	OKU0650004 ■

- Chiave inclusa
- Key included
- Schlüssel inbegriffen

### SPINNER

MOD: TC800 SMCY (BMT65)

MODULO MOTORIZZATO RADIALE MAGGIORATO MTSK

Radial MTSK reinforced driven tool

Radial MTSK angetriebenes Werkzeug vergroessert

Subject to change without notice.

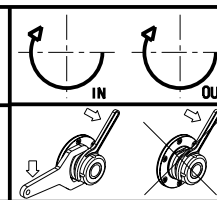

### M.T. srl

Via Casino Albini 480  
Tel. 0541/956034-957884  
Fax 0541/956341  
47842 S. GIOVANNI IN M. (RN)  
e-mail: mtma@mtmarchetti.com  
http://www.mtmarchetti.com

PRODUZIONE MODULI ROTANTI



PAGINA SPN020-2-01-K



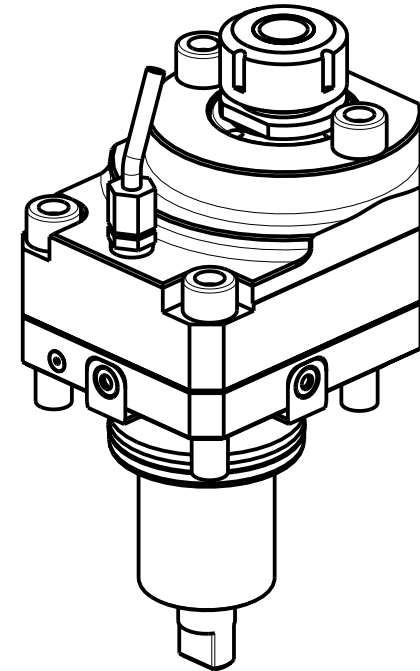
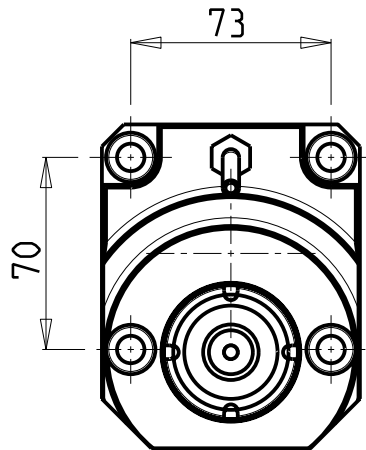
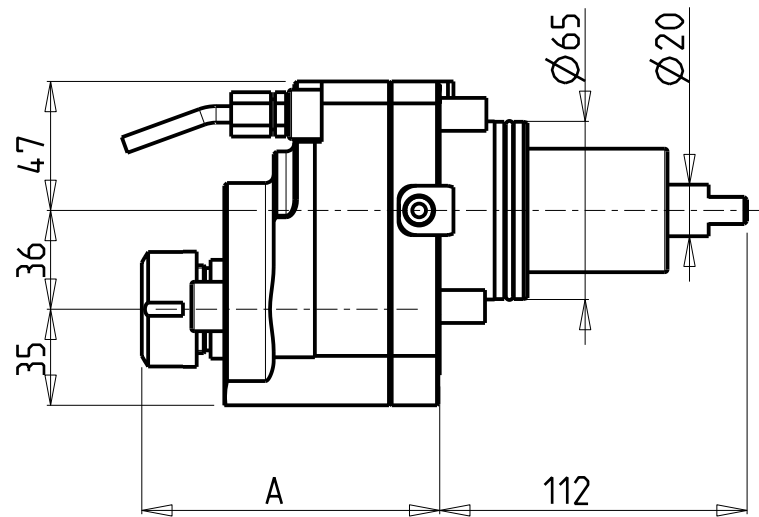
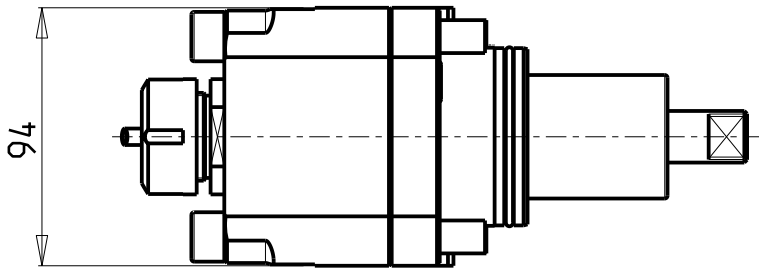

Cod. MT	Mandrino Spindle Spindel	I	RPM	Coppia Max Max Torque Max Drehmoment	Reversibile lato mandrino/contromandrino Reversible sub/main spindle side Umkehrbare Spindel-seite/ Gegenspindel-seite	Lubrificazione est. Ext. coolant Aussenkuehlung	A	CHIAVI NON INCLUSE Keys not included Schluessel nicht einbegriffen
DW00140125	ER25	1:2	12000	30Nm	X	X	108.56	CHSTER25 MNL0210007

**SPINNER**  
MOD: TC800 SMCY (BMT65)

MODULO MOTORIZZATO RADIALE MOLTIPLICATO I=1:2 DISASSATO IN Z 36mm  
Radial geared-up I=1:2 driven tool re-directed in Z by 36mm  
Radial angetriebenes Werkzeug uebersetzt I=1:2 achsversetzt in Z um 36mm

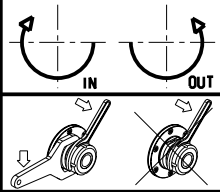

**M.T. srl**  
Via Casino Albini 480  
Tel. 0541/956034-957884  
Fax 0541/956341  
47842 S. GIOVANNI IN M. (RN)  
e-mail: mtma@mtmarchetti.com  
http://www.mtmarchetti.com

PRODUZIONE MODULI ROTANTI



PAGINA SPN030-2-30

Subject to change without notice.

10/2018

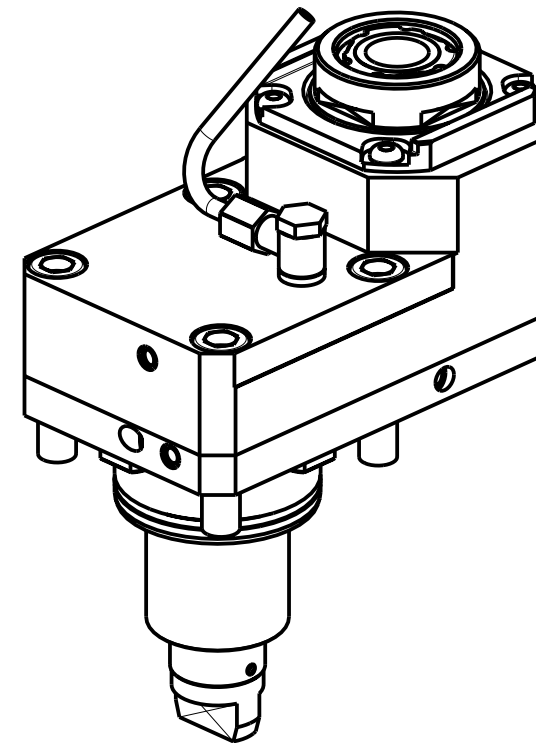
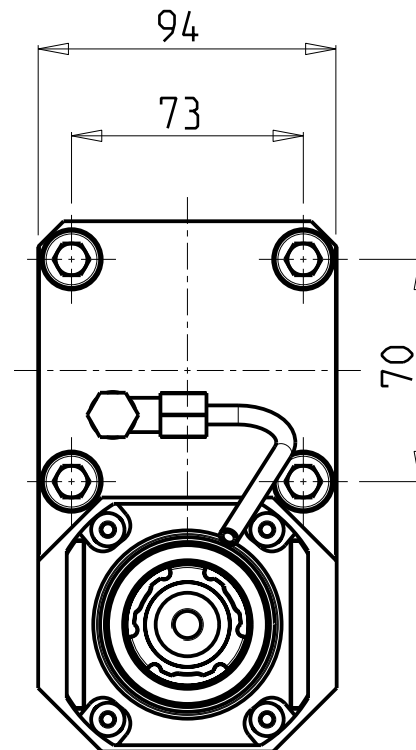
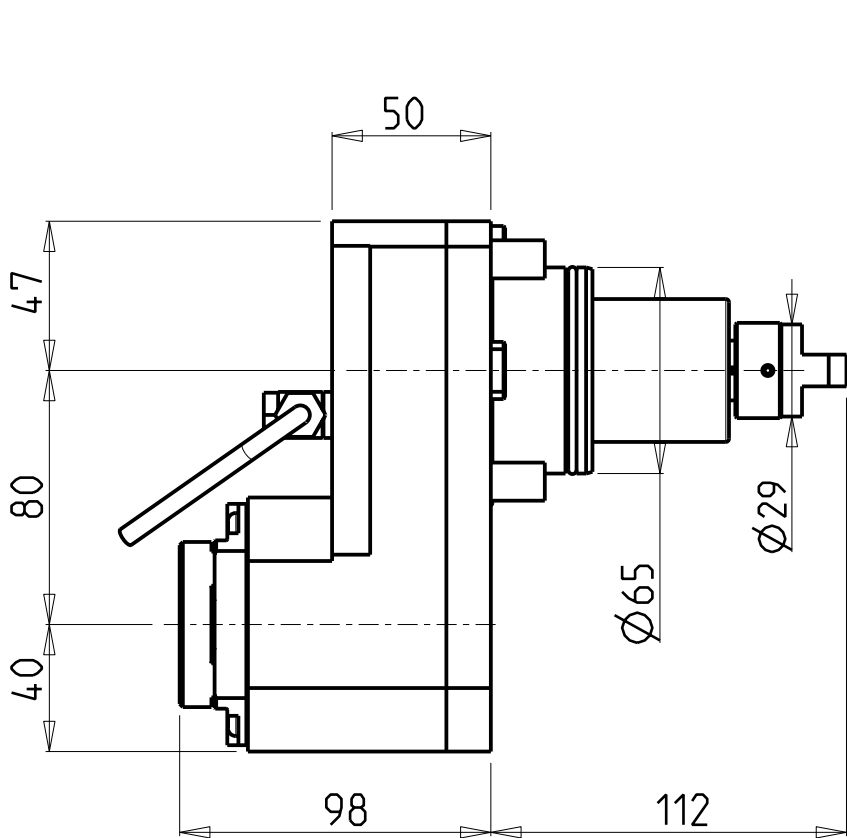

Cod. MT	Mandrino Spindle Spindel	I	RPM	Coppia Max Max Torque Max Drehmoment	Reversibile lato mandrino/contromandrino Reversible sub/main spindle side Umkehrbare Spindel-seite/ Gegenspindel-seite	Lubrificazione est. Ext. coolant Aussenkuehlung	CHIAVI NON INCLUSE Keys not included Schlüssel nicht einbegriffen		
DW01580332	ERA32	2:1	3000	90Nm	X	X	CHUB30	OKU0650004	CHTAER32ZC

- Chiave inclusa
- Key included
- Schlüssel inbegriffen

**SPINNER**  
MOD: TC800 SMCY (BMT65)

MODULO MOTORIZZATO RADIALE RIDOTTO I=2:1 DISASSATO IN Z 80mm  
Radial geared-down I=2:1 driven tool re-directed in Z by 80mm  
Radial angetriebenes Werkzeug untersetzt I=2:1 achsversetzt in Z um 80mm

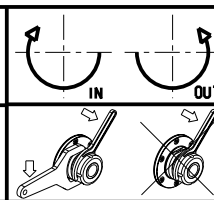

**M.T. srl**  
Via Casino Albini 480  
Tel. 0541/956034-957884  
Fax 0541/956341  
47842 S. GIOVANNI IN M. (RN)  
e-mail: mtma@mtmarchetti.com  
http://www.mtmarchetti.com

PRODUZIONE MODULI ROTANTI



PAGINA SPN033-2-20

Subject to change without notice.

10/2018

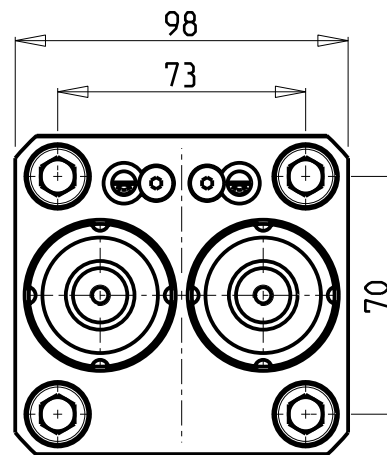
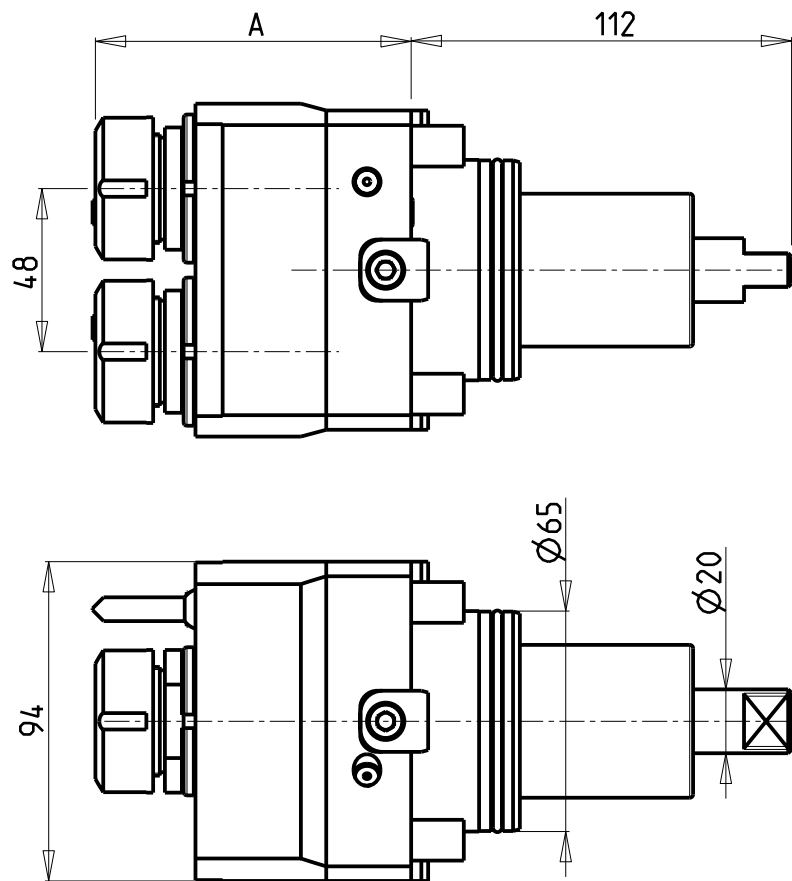

### ATTENZIONE - ATTENTION - ACHTUNG

- Per lo smontaggio degli utensili utilizzare sempre la chiave di contrasto come indicato nel manuale d'uso.
- For disassembly of the tools use always the contrast key as mentioned in the user instructions.
- Fuer das Abmontieren der Werkzeuge immer den Gegenschlüssel benutzen wie in der Bedienungsanleitung erwäehnt.

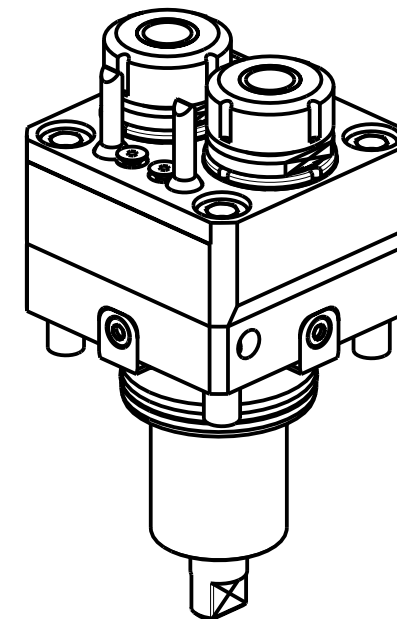

Cod. MT	Mandrino Spindle Spindel	I	RPM	Coppia Max Max Torque Max Drehmoment	Lubrificazione est. Ext. coolant Aussenkuehlung	A	CHIAVI NON INCLUSE Keys not included Schluesssel nicht einbegriffen	
DW 00540216	ER16	1:1	6000	30Nm	X	84.5	CHMNER16	CHUB17
DW 00540225	ER25	1:1	6000	30Nm	X	85	CHSTER25	MNLO210007

**SPINNER**  
MOD: TC800 SMCY (BMT65)

MODULO MOTORIZZATO RADIALE 2 USCITE IN Y  
Radial single side twin head driven tool in Y  
Radial angetriebenes Werkzeug 2 Ausgaenge in Y

Subject to change without notice.

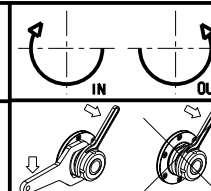

**M.T. srl**  
Via Casino Albini 480  
Tel. 0541/956034-957884  
Fax 0541/956341  
47842 S. GIOVANNI IN M. (RN)  
e-mail: mtma@mtmarchetti.com  
http://www.mtmarchetti.com

PRODUZIONE MODULI ROTANTI



PAGINA SPN080-2-00

**ATTENZIONE - ATTENTION - ACHTUNG**

- Per lo smontaggio degli utensili utilizzare sempre la chiave di contrasto come indicato nel manuale d'uso.
- For disassembly of the tools use always the contrast key as mentioned in the user instructions.
- Fuer das Abmontieren der Werkzeuge immer den Gegenschlüssel benutzen wie in der Bedienungsanleitung erwaeht.

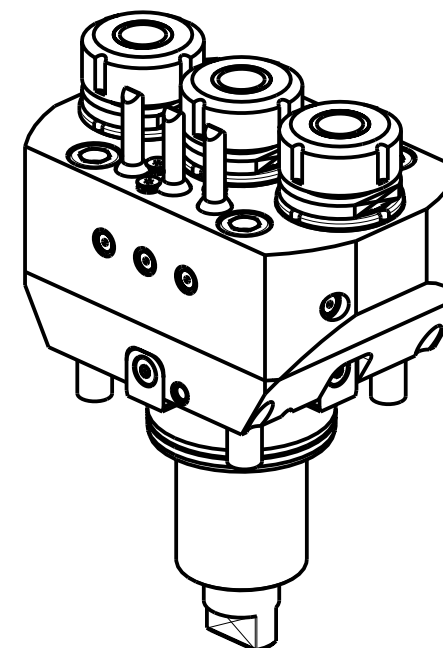
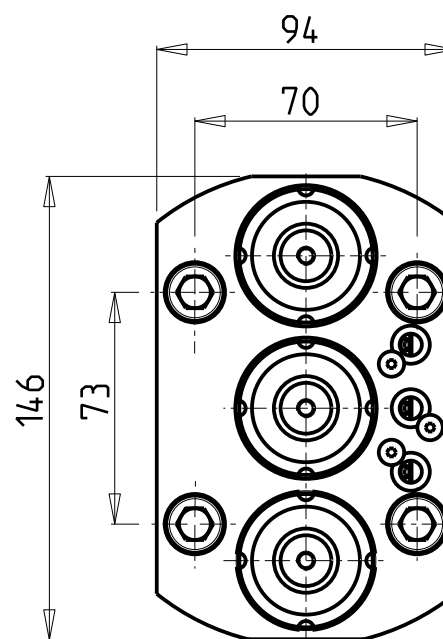
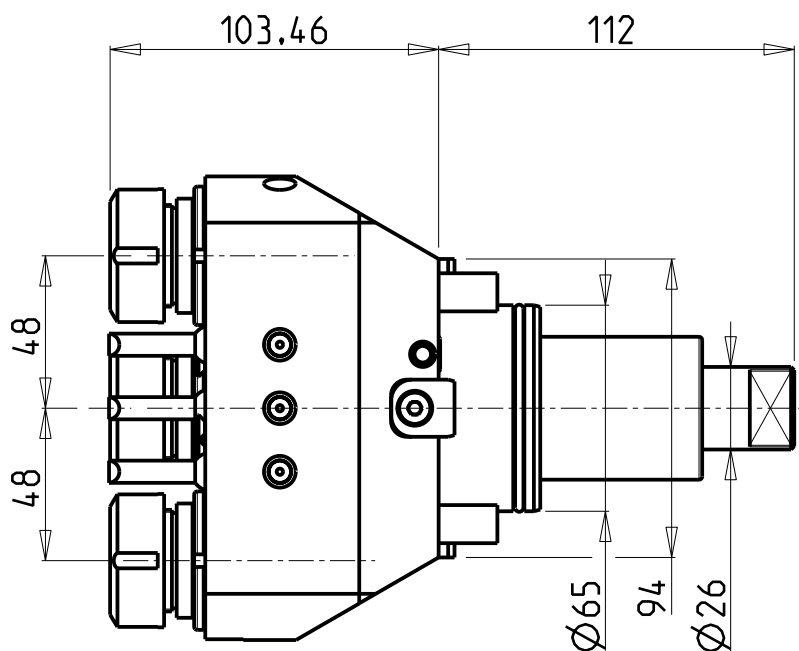

Cod. MT	Mandrino Spindle Spindel	I	RPM	Coppia Max Max Torque Max Drehmoment	Lubrificazione est. Ext. coolant Aussenkuehlung	CHIAVI INCLUSE Keys included Schluessel inbegriffen	
DW 01350325	ER25	1:1	6000	30Nm	X	MNL0210007	MNL0210008

**SPINNER**  
MOD: TC800 SMCY (BMT65)

MODULO MOTORIZZATO RADIALE 3 USCITE IN Y  
Radial single side 3 outlet driven tool in Y  
Radial angetriebenes Werkzeug 3 Ausgaenge in Y

Subject to change without notice.

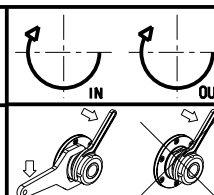

**M.T. srl**  
Via Casino Albini 480  
Tel. 0541/956034-957884  
Fax 0541/956341  
47842 S. GIOVANNI IN M. (RN)  
e-mail: mtma@mtmarchetti.com  
http://www.mtmarchetti.com

PRODUZIONE MODULI ROTANTI



PAGINA SPN095-2-00

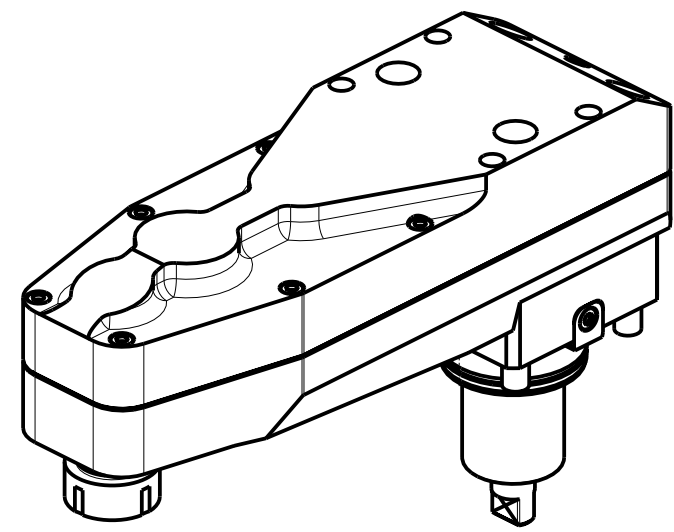
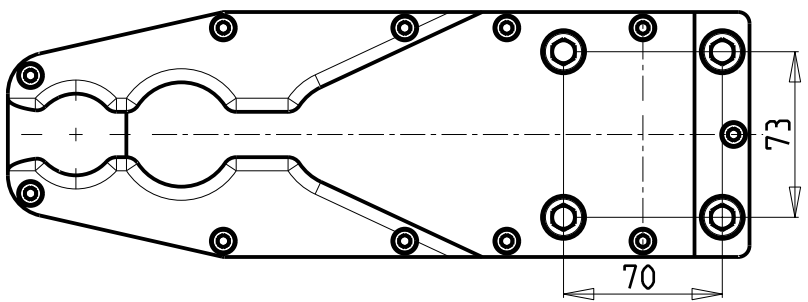
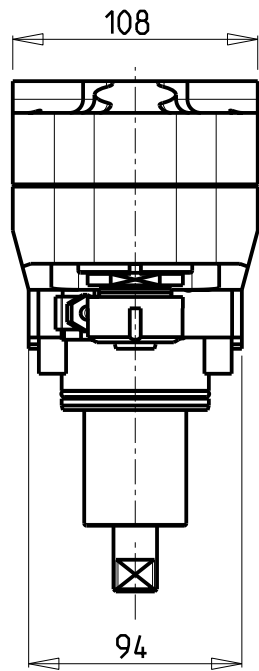
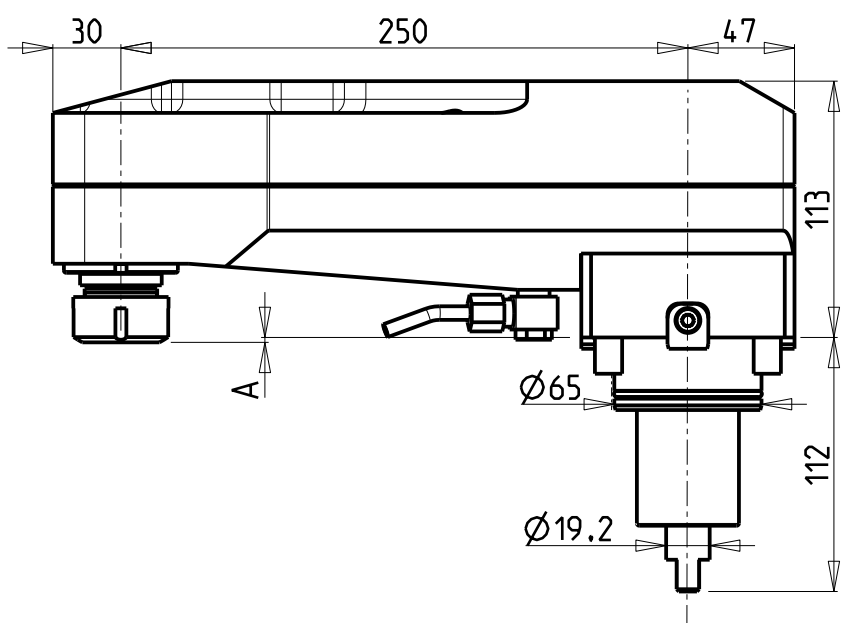

Cod. MT	Mandrino Spindle Spindel	I	RPM	Coppia Max Max Torque Max Drehmoment	Lubrificazione est. Ext. coolant Aussenkuehlung	A	CHIAVI NON INCLUSE Keys not included Schlüssel nicht einbegriffen	
0700025	ER25	1:2	12000	30Nm	X	2.16	CHSTER25	CHUB36
0700032	ER32	1:2	12000	30Nm	X	14.66	CHSTER32	CHUB36

**SPINNER**  
MOD: TC800 SMCY (BMT65)

MODULO MOTORIZZATO RADIALE ROVESCiato DISASSATO IN Z 250mm  
Radial inverted driven tool re-directed in Z by 250mm  
Radial angetriebenes Werkzeug ungekehrt achsversetzt in Z um 250mm

Subject to change without notice.

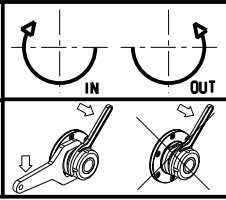

**M.T. srl**  
Via Casino Albini 480  
Tel. 0541/956034-957884  
Fax 0541/956341  
47842 S. GIOVANNI IN M. (RN)  
e-mail: mtma@mtmarchetti.com  
http://www.mtmarchetti.com

PRODUZIONE MODULI ROTANTI



PAGINA SPN120-2-10

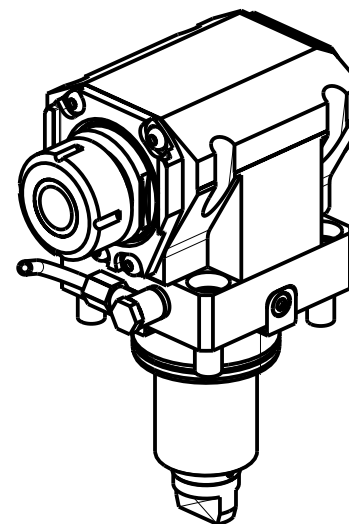
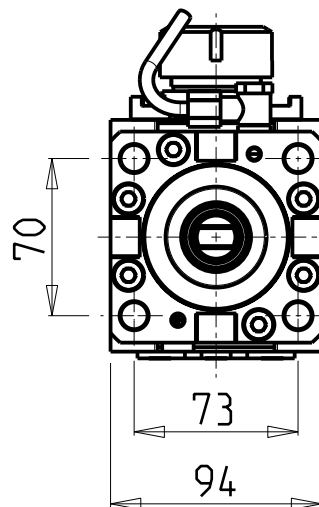
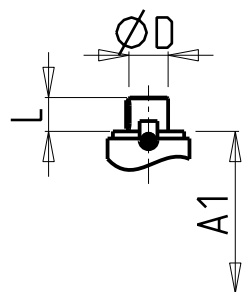
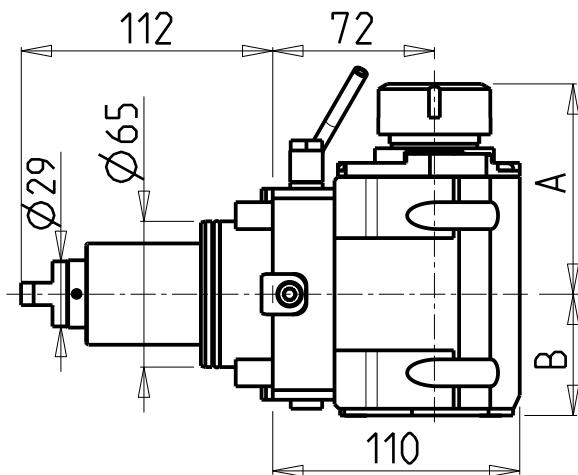

- Chiave inclusa
- Key included
- Schluessel inbegriffen

Cod. MT	Mandrino Spindle Spindel	I	RPM	Coppia Max Max Torque Max Drehmoment	Reversibile lato mandrino/contromandrino Reversible sub/main spindle side Umkehrbare Spindelseite/ Gegenspindelseite	Lubr.interna Coolant through Innenkuehlung	Lubr.esterna Ext. coolant Aussenkuehlung	A	A1	B	D	L	CHIAVI NON INCLUDE Keys not included Schluessel nicht einbegriffen		
DW 00700125	ER25	1:1	6000	100Nm	X	-	X	91.16	-	54	-	-	-	CHSTER25	OKU0650004 ■
DW 00700225	ER25	1:1	6000	100Nm	X	P=70bar	X	91.16	-	65	-	-	-	CHSTER25	OKU0650004 ■
DW 00700132	ER32	1:1	6000	100Nm	X	-	X	93.66	-	54	-	-	-	CHSTER32	OKU0650004 ■
DW 00700232	ER32	1:1	6000	100Nm	X	P=70bar	X	93.66	-	65	-	-	-	CHSTER32	OKU0650004 ■
DW 00700140	ER40	1:1	6000	100Nm	X	-	X	98.16	-	54	-	-	-	CHSTER40	OKU0650004 ■
DW 00700240	ER40	1:1	6000	100Nm	X	P=70bar	X	98.16	-	65	-	-	-	CHSTER40	OKU0650004 ■
DW 00700325	ERA25	1:1	6000	100Nm	X	-	X	65	-	54	-	-	CHUB27	CHTAER25ZC ■	OKU0650004 ■
DW 00700425	ERA25	1:1	6000	100Nm	X	P=70bar	X	65	-	65	-	-	CHUB27	CHTAER25ZC ■	OKU0650004 ■
DW 00700516	Ø16x17	1:1	6000	100Nm	X	-	X	-	67.5	54	16	17	-	CH_VTCROCE_M08 ■	OKU0650004 ■
DW 00700522	Ø22x19	1:1	6000	100Nm	X	-	X	-	67.5	54	22	19	-	CH_VTCROCE_M10 ■	OKU0650004 ■
DW 00700527	Ø27x21	1:1	6000	100Nm	X	-	X	-	70	54	27	21	-	CH_VTCROCE_M12 ■	OKU0650004 ■

## SPINNER

MOD: TC800 SMCY (BMT65)

MODULO MOTORIZZATO ASSIALE H=72mm

Axial driven tool H=72mm

Axial angetriebenes Werkzeug H=72mm

Subject to change without notice.

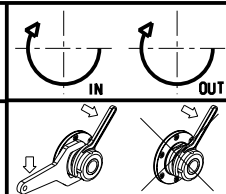

## M.T. srl

Via Casino Albini 480  
Tel. 0541/956034-957884  
Fax 0541/956341

47842 S. GIOVANNI IN M. (RN)  
e-mail: mtma@mtmarchetti.com  
http://www.mtmarchetti.com

PRODUZIONE MODULI ROTANTI



PAGINA SPN150-2-11

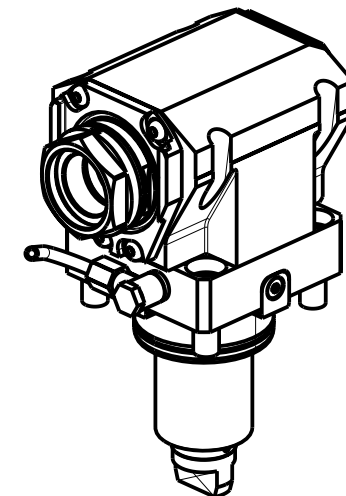
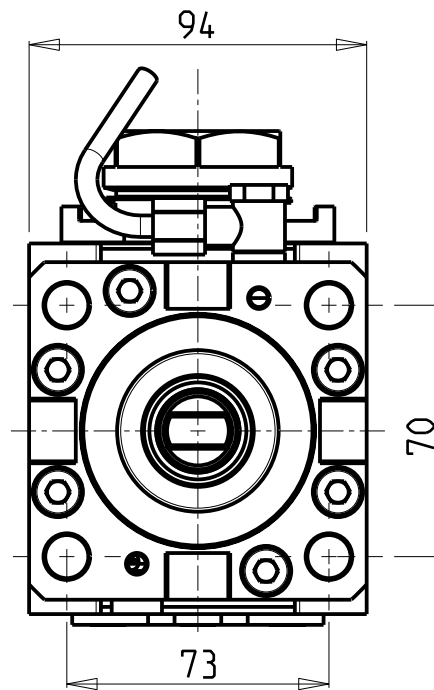
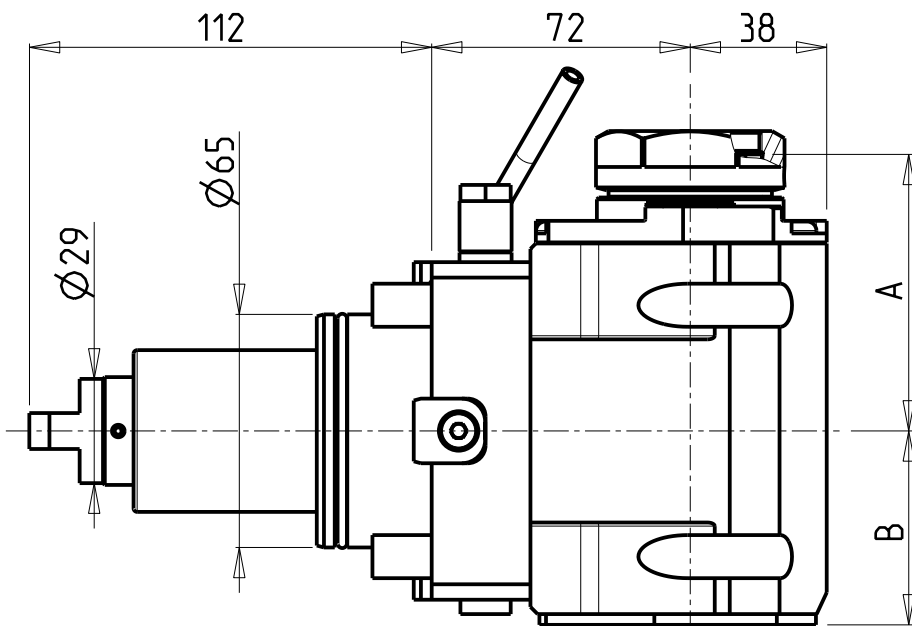

PER PORTAUTENSILI MODULARI MTSK-40 VEDI PAG. TBL300-1-40 E PER MTSK-50 VEDI PAG. TBL300-1-50  
 FOR MTSK-40 QUICK CHANGE TOOLHOLDERS CLAMPINGS SEE PAGE TBL300-1-40 AND FOR MTSK-50 SEE PAGE TBL300-1-50  
 FUER MTSK-40 MODULARE WERKZEUGAUFNAHMEN SIEHE SEITE TBL300-1-40 UND FUER MTSK-50 SIEHE SEITE TBL300-1-50

Cod. MT	Mandrino Spindle Spindel	I	RPM	Coppia Max Max Torque Max Drehmoment	Reversibile lato mandrino/contromandrino Reversible sub/main spindle side Umkehrbare Spindel-seite/ Gegenspindel-seite	Lubr.interna Coolant through Innenkuehlung	Lubr.esterna Ext. coolant Aussenkuehlung	A	B	CHIAVI NON INCLUSE Keys not included Schlüssel nicht einbegriffen	
DW 01170140	MTSK-40	1:1	6000	100Nm	X	-	X	77	54	CHUB46	OKU0650004 •
DW 01170240	MTSK-40	1:1	6000	100Nm	X	P=70bar	X	77	65	CHUB46	OKU0650004 •
DW 01170150	MTSK-50	1:1	6000	100Nm	X	-	X	79	54	CHUB55	OKU0650004 •
DW 01170250	MTSK-50	1:1	6000	100Nm	X	P=70bar	X	79	65	CHUB55	OKU0650004 •

- Chiave inclusa
- Key included
- Schlüssel inbegriffen

### SPINNER

MOD: TC800 SMCY (BMT65)

MODULO MOTORIZZATO ASSIALE MTSK H=72mm

Axial MTSK driven tool H=72mm

Axial MTSK angetriebenes Werkzeug H=72mm

Subject to change without notice.

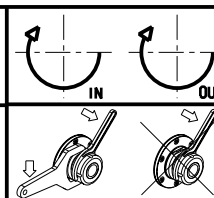

### M.T. srl

Via Casino Albini 480  
 Tel. 0541/956034-957884  
 Fax 0541/956341  
 47842 S. GIOVANNI IN M. (RN)  
 e-mail: mtma@tmarchetti.com  
 http://www.tmmarchetti.com

PRODUZIONE MODULI ROTANTI



PAGINA SPN150-2-11-K

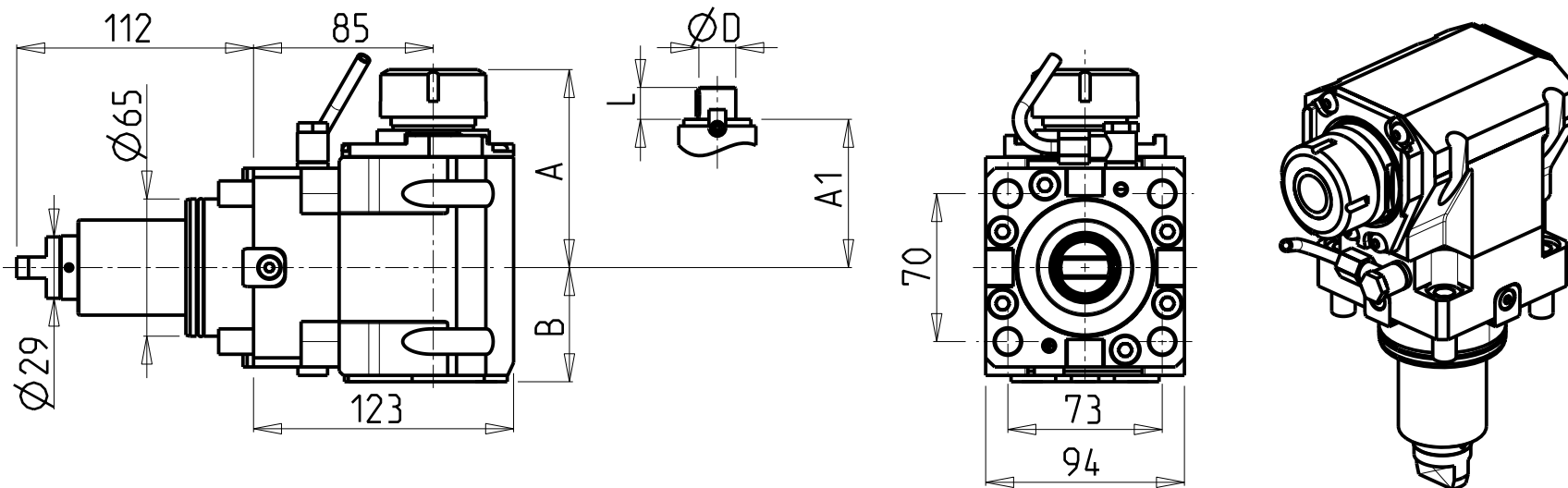

- Chiave inclusa
- Key included
- Schluessel inbegriffen

Cod. MT	Mandrino Spindle Spindel	I	RPM	Coppia Max Max Torque Max Drehmoment	Reversibile lato mandrino/contromandrino Reversible sub/main spindle side Umkehrbare Spindel-seite/ Gegenspindel-seite	Lubr.interna Coolant through Innenkuehlung	Lubr.esterna Ext. coolant Aussenkuehlung	A	A1	B	D	L	CHIAVI NON INCLUDE Keys not included Schluessel nicht einbegriffen		
DW 01130125	ER25	1:1	6000	100Nm	X	-	X	91.16	-	54	-	-	CHSTER25	OKU0650004	
DW 01130225	ER25	1:1	6000	100Nm	X	P=70bar	X	91.16	-	65	-	-	CHSTER25	OKU0650004	
DW 01130132	ER32	1:1	6000	100Nm	X	-	X	93.66	-	54	-	-	CHSTER32	OKU0650004	
DW 01130232	ER32	1:1	6000	100Nm	X	P=70bar	X	93.66	-	65	-	-	CHSTER32	OKU0650004	
DW 01130140	ER40	1:1	6000	100Nm	X	-	X	98.16	-	54	-	-	CHSTER40	OKU0650004	
DW 01130240	ER40	1:1	6000	100Nm	X	P=70bar	X	98.16	-	65	-	-	CHSTER40	OKU0650004	
DW 01130325	ERA25	1:1	6000	100Nm	X	-	X	65	-	54	-	-	CHUB27	CHTAER25ZC	OKU0650004
DW 01130425	ERA25	1:1	6000	100Nm	X	P=70bar	X	65	-	65	-	-	CHUB27	CHTAER25ZC	OKU0650004
DW 01130516	Ø16x17	1:1	6000	100Nm	X	-	X	-	67.5	54	16	17	CH_VTCROCE_M08	OKU0650004	
DW 01130522	Ø22x19	1:1	6000	100Nm	X	-	X	-	67.5	54	22	19	CH_VTCROCE_M10	OKU0650004	
DW 01130527	Ø27x21	1:1	6000	100Nm	X	-	X	-	70	54	27	21	CH_VTCROCE_M12	OKU0650004	

**SPINNER**

MOD: TC800 SMCY (BMT65)

MODULO MOTORIZZATO ASSIALE H=85mm

Axial driven tool H=85mm

Axial angetriebenes Werkzeug H=85mm

Subject to change without notice.

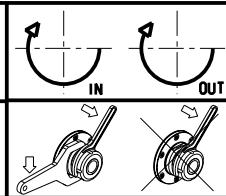

**M.T. srl**  
 Via Casino Albini 480  
 Tel. 0541/956034-957884  
 Fax 0541/956341  
 47842 S. GIOVANNI IN M. (RN)  
 e-mail: mtma@mtmarchetti.com  
 http://www.mtmarchetti.com

PRODUZIONE MODULI ROTANTI



PAGINA SPN150-2-15



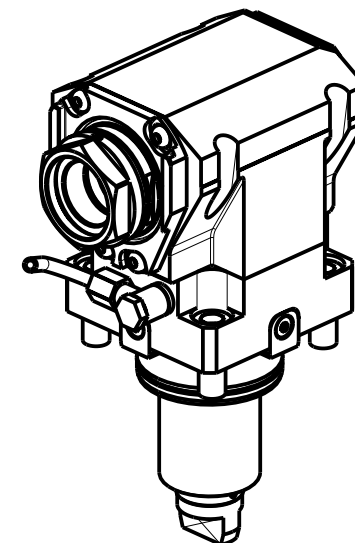
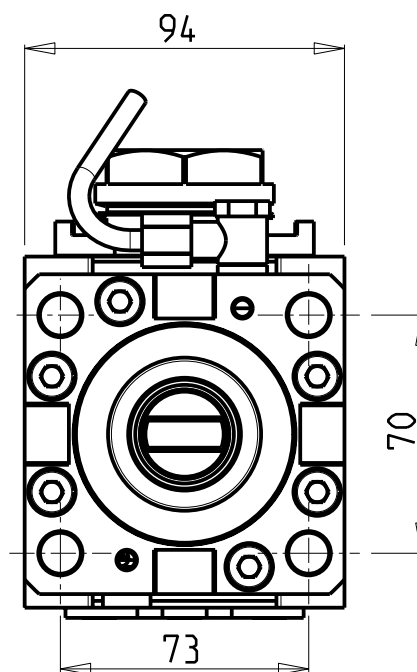
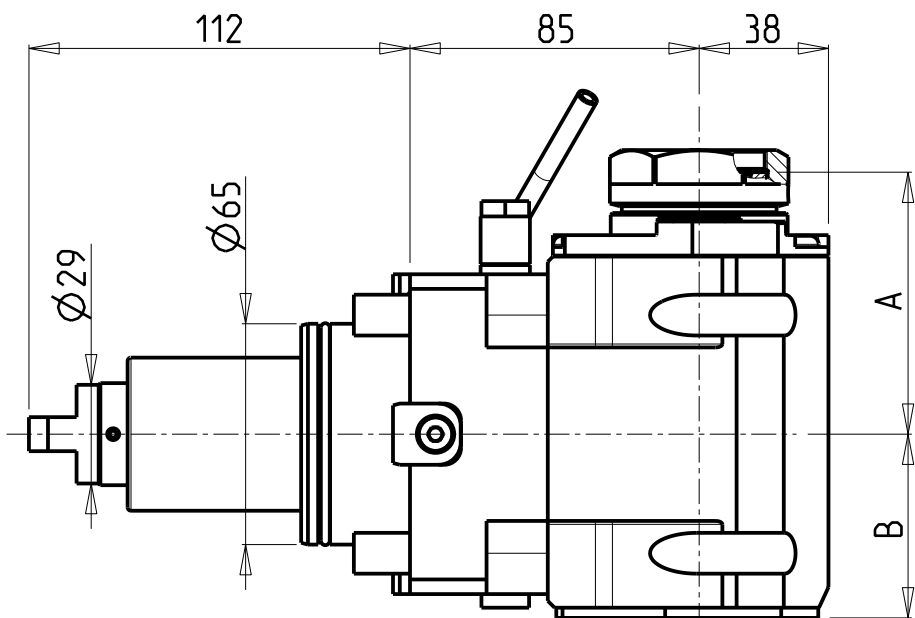

PER PORTAUTENSILI MODULARI MTSK-40 VEDI PAG. TBL300-1-40 E PER MTSK-50 VEDI PAG. TBL300-1-50  
 FOR MTSK-40 QUICK CHANGE TOOLHOLDERS CLAMPINGS SEE PAGE TBL300-1-40 AND FOR MTSK-50 SEE PAGE TBL300-1-50  
 FUER MTSK-40 MODULARE WERKZEUGAUFNAHMEN SIEHE SEITE TBL300-1-40 UND FUER MTSK-50 SIEHE SEITE TBL300-1-50

Cod. MT	Mandrino Spindle Spindel	I	RPM	Coppia Max Max Torque Max Drehmoment	Reversibile lato mandrino/contromandrino Reversible sub/main spindle side Umkehrbare Spindel-seite/Gegenspindel-seite	Lubr.interna Coolant through Innenkuehlung	Lubr.esterna Ext. coolant Aussenkuehlung	A	B	CHIAVI NON INCLUSE Keys not included Schluessel nicht einbegriffen	
DW 01180140	MTSK-40	1:1	6000	100Nm	X	-	X	77	54	CHUB46	OKU0650004 •
DW 01180240	MTSK-40	1:1	6000	100Nm	X	P=70bar	X	77	65	CHUB46	OKU0650004 •
DW 01180150	MTSK-50	1:1	6000	100Nm	X	-	X	79	54	CHUB55	OKU0650004 •
DW 01180250	MTSK-50	1:1	6000	100Nm	X	P=70bar	X	79	65	CHUB55	OKU0650004 •

- Chiave inclusa
- Key included
- Schluessel inbegriffen

### SPINNER

MOD: TC800 SMCY (BMT65)

MODULO MOTORIZZATO ASSIALE MTSK H=85mm

Axial MTSK driven tool H=85mm

Axial MTSK angetriebenes Werkzeug H=85mm

Subject to change without notice.

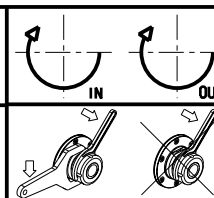

### M.T. srl

Via Casino Albini 480  
 Tel. 0541/956034-957884  
 Fax 0541/956341  
 47842 S. GIOVANNI IN M. (RN)  
 e-mail: mtma@mtmarchetti.com  
 http://www.mtmarchetti.com

PRODUZIONE MODULI ROTANTI



PAGINA SPN150-2-15-K

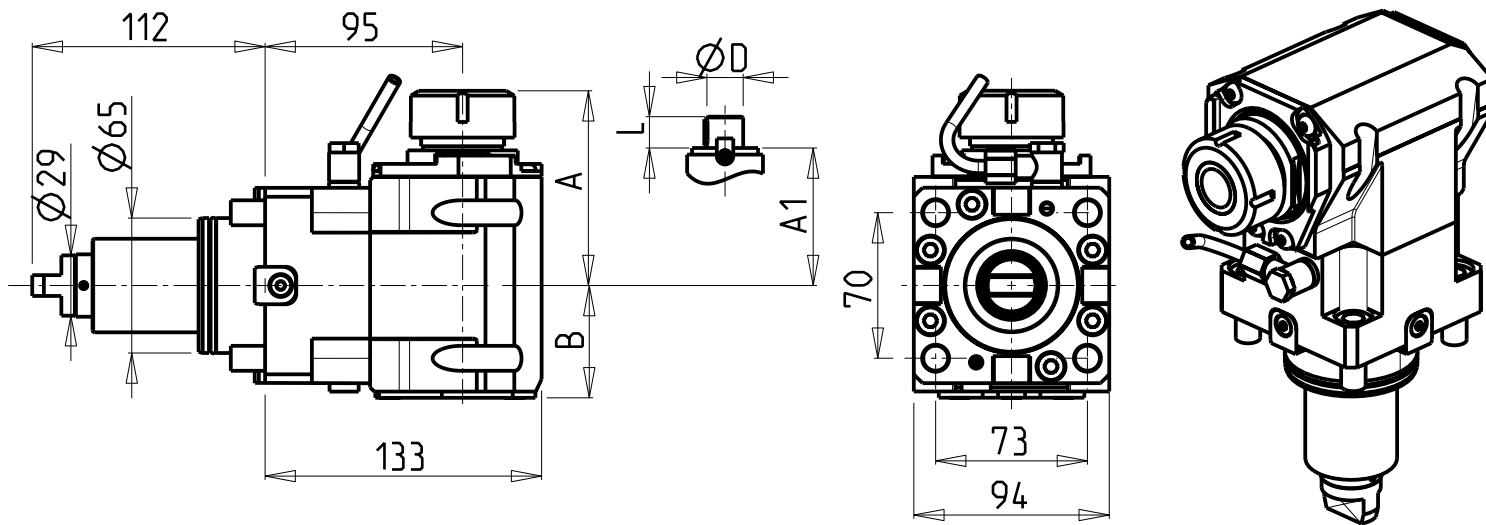

### ATTENZIONE - ATTENTION - ACHTUNG

- VERIFICARE LE MISURE DI INGOMBRO PER POSSIBILE INTERFERENZA SU ALCUNI MODELLI DI MACCHINE
- Please check the overall sizes for possible interferences on some machine models
- Bitte überprüfen sie das ausmass um mögliche interferenzen auf einigen maschinen modellen zu vermeiden

- Chiave inclusa
- Key included
- Schluessel inbegriffen

Cod. MT	Mandrino Spindle Spindel	I	RPM	Coppia Max Max Torque Max Drehmoment	Reversibile lato mandrino/contromandrino Reversible sub/main spindle side Umkehrbare Spindel-seite/Gegenspindel-seite	Lubr.interna Coolant through Innenkuehlung	Lubr.esterna Ext. coolant Aussenkuehlung	A	A1	B	D	L	CHIAVI NON INCLUDE Keys not included Schluessel nicht einbegriffen		
DW 02510125	ER25	1:1	6000	100Nm	X	-	X	91.2	-	54	-	-	-	CHSTER25	OKU0650004
DW 02510225	ER25	1:1	6000	100Nm	X	P=70bar	X	91.2	-	65	-	-	-	CHSTER25	OKU0650004
DW 02510132	ER32	1:1	6000	100Nm	X	-	X	93.7	-	54	-	-	-	CHSTER32	OKU0650004
DW 02510232	ER32	1:1	6000	100Nm	X	P=70bar	X	93.7	-	65	-	-	-	CHSTER32	OKU0650004
DW 02510140	ER40	1:1	6000	100Nm	X	-	X	98.2	-	54	-	-	-	CHSTER40	OKU0650004
DW 02510240	ER40	1:1	6000	100Nm	X	P=70bar	X	98.2	-	65	-	-	-	CHSTER40	OKU0650004
DW 02510325	ERA25	1:1	6000	100Nm	X	-	X	65	-	54	-	-	CHUB27	CHTAER25ZC	OKU0650004
DW 02510425	ERA25	1:1	6000	100Nm	X	P=70bar	X	65	-	65	-	-	CHUB27	CHTAER25ZC	OKU0650004
DW 02510516	Ø16x17	1:1	6000	100Nm	X	-	X	-	67.5	54	16	17	-	CH_VTCROCE_M08	OKU0650004
DW 02510522	Ø22x19	1:1	6000	100Nm	X	-	X	-	67.5	54	22	19	-	CH_VTCROCE_M10	OKU0650004
DW 02510527	Ø27x21	1:1	6000	100Nm	X	-	X	-	70	54	27	21	-	CH_VTCROCE_M12	OKU0650004

### SPINNER

MOD: TC800 SMCY (BMT65)

MODULO MOTORIZZATO ASSIALE H=95mm

Axial driven tool H=95mm

Axial angetriebenes Werkzeug H=95mm

Subject to change without notice.

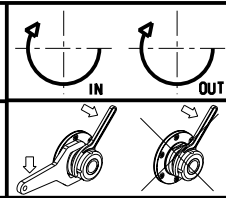

### M.T. srl

Via Casino Albini 480  
Tel. 0541/956034-957884  
Fax 0541/956341  
47842 S. GIOVANNI IN M. (RN)  
e-mail: mtma@mtmarchetti.com  
http://www.mtmarchetti.com

PRODUZIONE MODULI ROTANTI



PAGINA SPN150-2-18

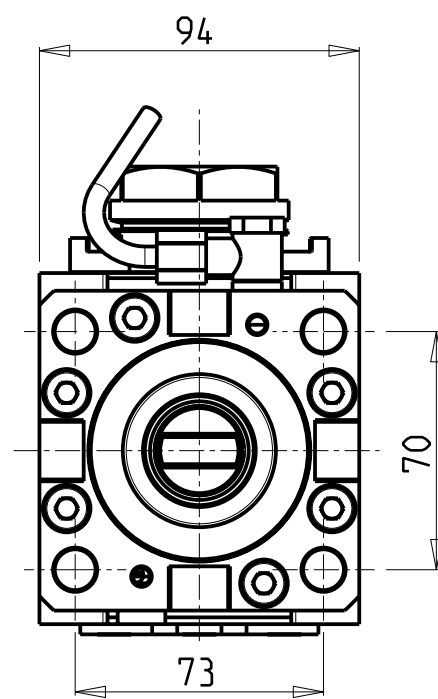
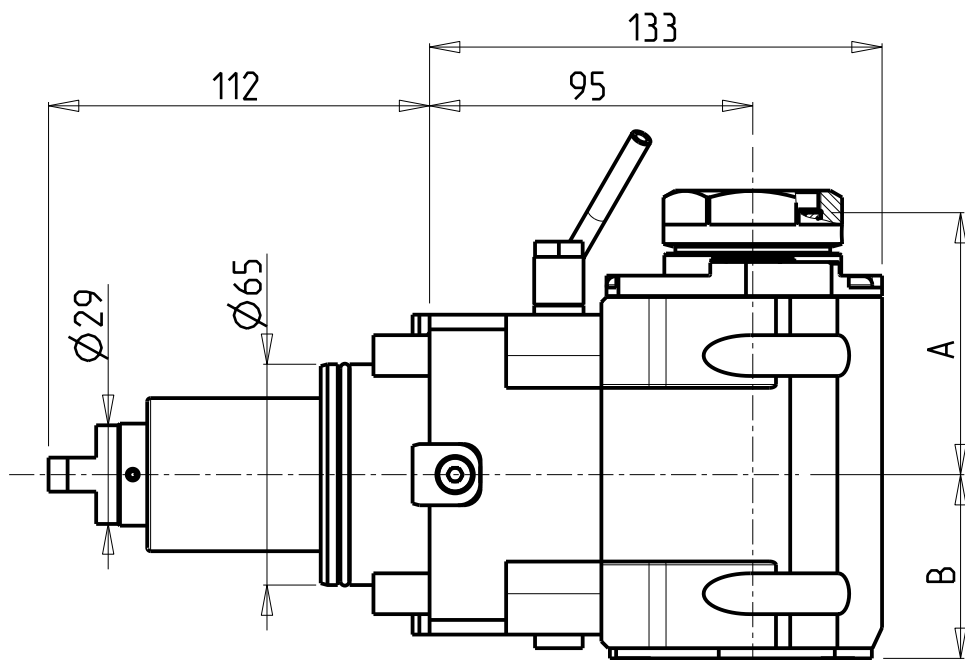

**ATTENZIONE - ATTENTION - ACHTUNG**

- VERIFICARE LE MISURE DI INGOMBRO PER POSSIBILE INTERFERENZA SU ALCUNI MODELLI DI MACCHINE
- Please check the overall sizes for possible interferences on some machine models
- Bitte überprüfen sie das ausmass um mögliche interferenzen auf einigen maschinen modellen zu vermeiden

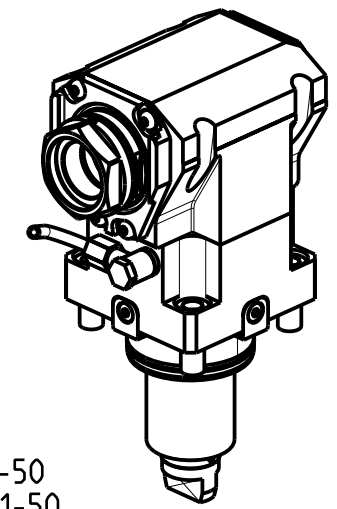

PER PORTAUTENSILI MODULARI MTSK-40 VEDI PAG. TBL300-1-40 E PER MTSK-50 VEDI PAG. TBL300-1-50  
 FOR MTSK-40 QUICK CHANGE TOOLHOLDERS CLAMPINGS SEE PAGE TBL300-1-40 AND FOR MTSK-50 SEE PAGE TBL300-1-50  
 FUER MTSK-40 MODULARE WERKZEUGAUFNAHMEN SIEHE SEITE TBL300-1-40 UND FUER MTSK-50 SIEHE SEITE TBL300-1-50

Cod. MT	Mandrino Spindle Spindel	I	RPM	Coppia Max Max Torque Max Drehmoment	Reversibile lato mandrino/contromandrino	Lubr.interna Coolant through Innenkuehlung	Lubr.esterna Ext. coolant Aussenkuehlung	A	B	CHIAVI NON INCLUSE	
					Reversible sub/main spindle side Umkehrbare Spindel-seite/Gegenspindel-seite					Keys not included	Schlüssel nicht einbegriffen
DW 02530140	MTSK-40	1:1	6000	100Nm	X	-	X	77	54	CHUB46	OKU0650004
DW 02530240	MTSK-40	1:1	6000	100Nm	X	P=70bar	X	77	65	CHUB46	OKU0650004
DW 02530150	MTSK-50	1:1	6000	100Nm	X	-	X	79	54	CHUB55	OKU0650004
DW 02530250	MTSK-50	1:1	6000	100Nm	X	P=70bar	X	79	65	CHUB55	OKU0650004

- Chiave inclusa
- Key included
- Schlüssel inbegriffen

**SPINNER**  
 MOD: TC800 SMCY (BMT65)

MODULO MOTORIZZATO ASSIALE MTSK H=95mm  
 Axial MTSK driven tool H=95mm  
 Axial MTSK angetriebenes Werkzeug H=95mm

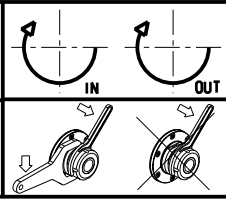

**M.T. srl**  
 Via Casino Albini 480  
 Tel. 0541/956034-957884  
 Fax 0541/956341  
 47842 S. GIOVANNI IN M. (RN)  
 e-mail: mtma@mtmarchetti.com  
 http://www.mtmarchetti.com

PRODUZIONE MODULI ROTANTI  
  
 PAGINA SPN150-2-18-K

Subject to change without notice.

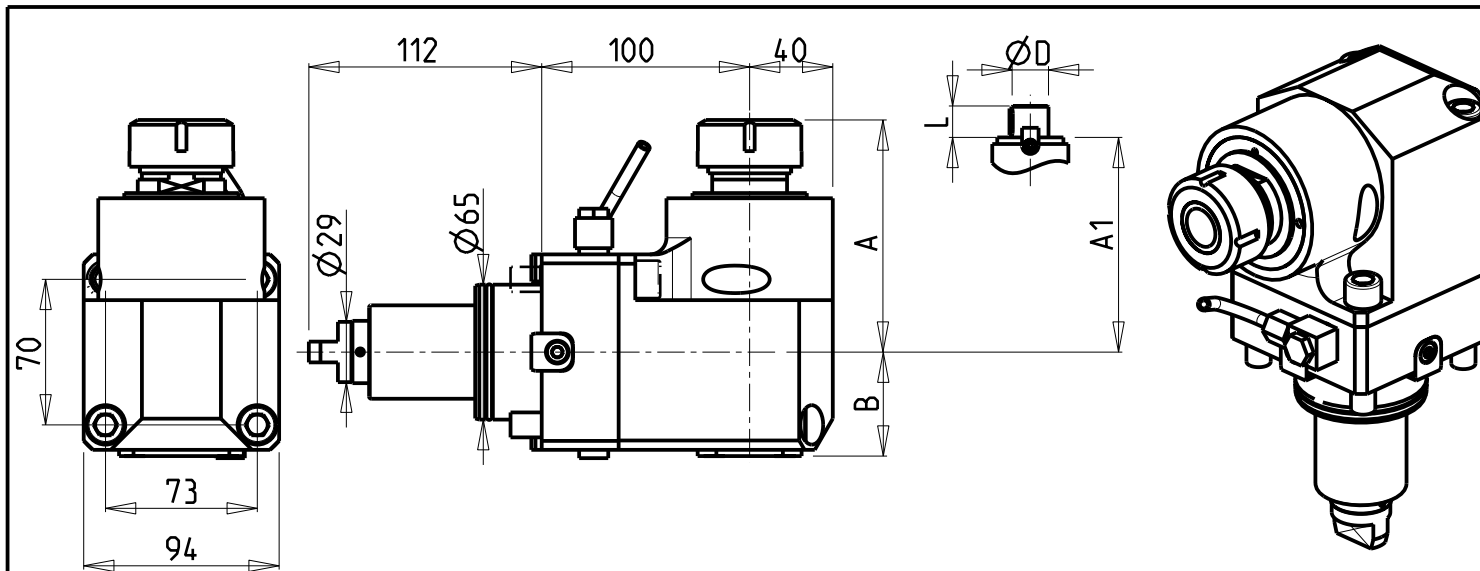

### ATTENZIONE - ATTENTION - ACHTUNG

- VERIFICARE LE MISURE DI INGOMBRO PER POSSIBILE INTERFERENZA SU ALCUNI MODELLI DI MACCHINE
- Please check the overall sizes for possible interferences on some machine models
- Bitte überprüfen sie das ausmass um mögliche interferenzen auf einigen maschinen modellen zu vermeiden

- Chiave inclusa
- Key included
- Schlüssel inbegriffen

Cod. MT	Mandrino Spindle Spindel	I	RPM	Coppia Max Max Drehmoment	Reversibile lato mandrino/contromandrino Reversible sub/main spindle side Umkehrbare Spindel-seite/ Gegenspindel-seite	Lubr.interna Coolant through Innenkuehlung	Lubr.esterna Ext. coolant Aussenkuehlung	A	A1	B	D	L	CHIAVI NON INCLUDE Keys not included Schluessel nicht einbegriffen	
0711432	ER32	1:1	6000	100Nm	X		X	111.56	-	47	-	-	CHSTER32	CHUB36
0711032	ER32	1:1	6000	100Nm	X	P=70bar	X	111.56	-	72	-	-	CHSTER32	CHUB36
0711532	ER A 32	1:1	6000	100Nm	X		X	102.03	-	47	-	-	CHUB50	CHUB32
0712640	ER40	1:1	6000	100Nm	X		X	115	-	47	-	-	CHSTER40	CHUB46
0712540	ER40	1:1	6000	100Nm	X	P=70bar	X	115	-	72	-	-	CHSTER40	CHUB46
0711617	Ø16x17	1:1	6000	100Nm	X		X	-	86	47	16	17	CH_VTCROCE_M08	CHUB36
0712219	Ø22x19	1:1	6000	100Nm	X		X	-	88	47	22	19	CH_VTCROCE_M10	CHUB36
0712240	Ø22x40	1:1	6000	100Nm	X		X	-	86	47	22	40	CH_VTCROCE_M10	CHUB36
0712721	Ø27x21	1:1	6000	100Nm	X		X	-	87.5	47	27	21	CH_VTCROCE_M12	CHUB36
0712733	Ø27x33	1:1	6000	100Nm	X		X	-	86	47	27	33	CH_VTCROCE_M12	CHUB36
0712750	Ø27x50	1:1	6000	100Nm	X		X	-	86	47	27	50	CH_VTCROCE_M12	CHUB36

### SPINNER

MOD: TC800 SMCY (BMT65)

MODULO MOTORIZZATO ASSIALE H=100mm

Axial driven tool H=100mm

Axial angetriebenes Werkzeug H=100mm

Subject to change without notice.

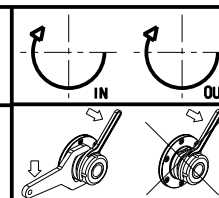

### M.T. srl

Via Casino Albini 480  
Tel. 0541/956034-957884  
Fax 0541/956341  
47842 S. GIOVANNI IN M. (RN)  
e-mail: mtma@mtmarchetti.com  
http://www.mtmarchetti.com

PRODUZIONE MODULI ROTANTI



PAGINA SPN150-2-20

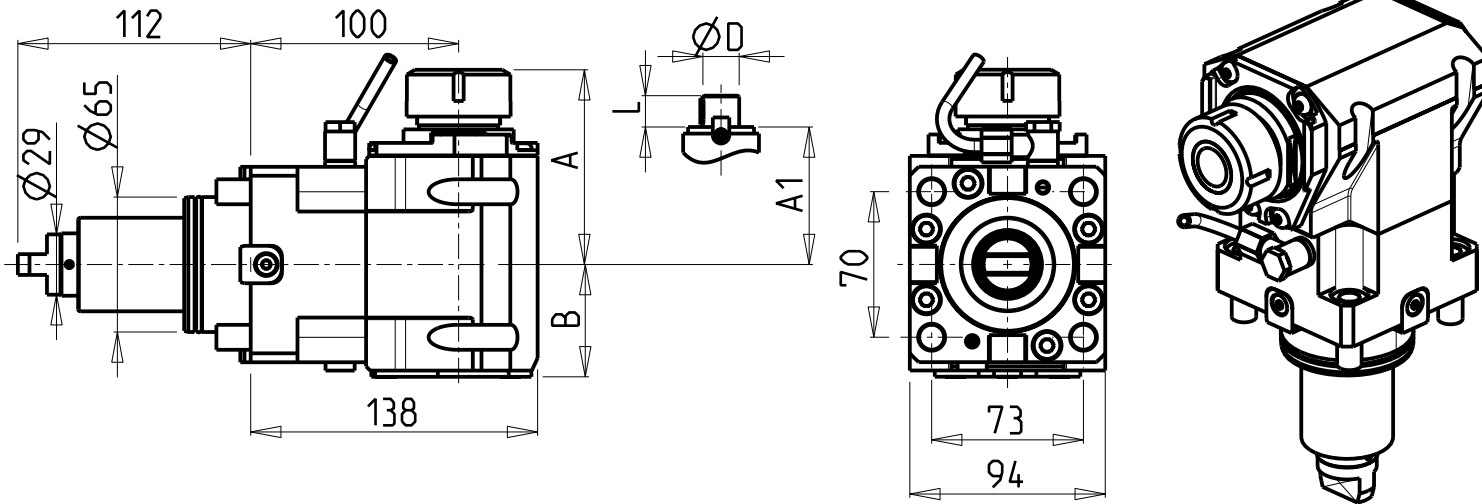

### ATTENZIONE - ATTENTION - ACHTUNG

- VERIFICARE LE MISURE DI INGOMBRO PER POSSIBILE INTERFERENZA SU ALCUNI MODELLI DI MACCHINE
- Please check the overall sizes for possible interferences on some machine models
- Bitte überprüfen sie das ausmass um mögliche interferenzen auf einigen maschinen modellen zu vermeiden

- Chiave inclusa
- Key included
- Schluessel inbegriffen

Cod. MT	Mandrino Spindle Spindel	I	RPM	Coppia Max Max Torque Max Drehmoment	Reversibile lato mandrino/contromandrino Reversible sub/main spindle side Umkehrbare Spindel-seite/Gegenspindel-seite	Lubr.interna Coolant through Innenkuehlung	Lubr.esterna Ext. coolant Aussenkuehlung	A	A1	B	D	L	CHIAVI NON INCLUDE Keys not included Schluessel nicht einbegriffen	
DW 0114 0125	ER25	1:1	6000	100Nm	X	-	X	91.16	-	54	-	-	CHSTER25	OKU0650004
DW 0114 0225	ER25	1:1	6000	100Nm	X	P=70bar	X	91.16	-	65	-	-	CHSTER25	OKU0650004
DW 0114 0132	ER32	1:1	6000	100Nm	X	-	X	93.66	-	54	-	-	CHSTER32	OKU0650004
DW 0114 0232	ER32	1:1	6000	100Nm	X	P=70bar	X	93.66	-	65	-	-	CHSTER32	OKU0650004
DW 0114 0140	ER40	1:1	6000	100Nm	X	-	X	98.16	-	54	-	-	CHSTER40	OKU0650004
DW 0114 0240	ER40	1:1	6000	100Nm	X	P=70bar	X	98.16	-	65	-	-	CHSTER40	OKU0650004
DW 0114 0325	ERA25	1:1	6000	100Nm	X	-	X	65	-	54	-	CHUB27	CHTAER25ZC	OKU0650004
DW 0114 0425	ERA25	1:1	6000	100Nm	X	P=70bar	X	65	-	65	-	CHUB27	CHTAER25ZC	OKU0650004
DW 0114 0516	Ø16x17	1:1	6000	100Nm	X	-	X	-	67.5	54	16	17	CH_VTCROCE_M08	OKU0650004
DW 0114 0522	Ø22x19	1:1	6000	100Nm	X	-	X	-	67.5	54	22	19	CH_VTCROCE_M10	OKU0650004
DW 0114 0527	Ø27x21	1:1	6000	100Nm	X	-	X	-	70	54	27	21	CH_VTCROCE_M12	OKU0650004

### SPINNER

MOD: TC800 SMCY (BMT65)

MODULO MOTORIZZATO ASSIALE H=100mm

Axial driven tool H=100mm

Axial angetriebenes Werkzeug H=100mm

Subject to change without notice.

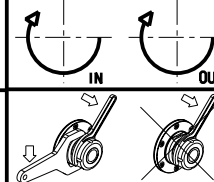

### M.T. srl

Via Casino Albini 480  
Tel. 0541/956034-957884  
Fax 0541/956341  
47842 S. GIOVANNI IN M. (RN)  
e-mail: mtma@mtmarchetti.com  
http://www.mtmarchetti.com

PRODUZIONE MODULI ROTANTI



PAGINA SPN150-2-21

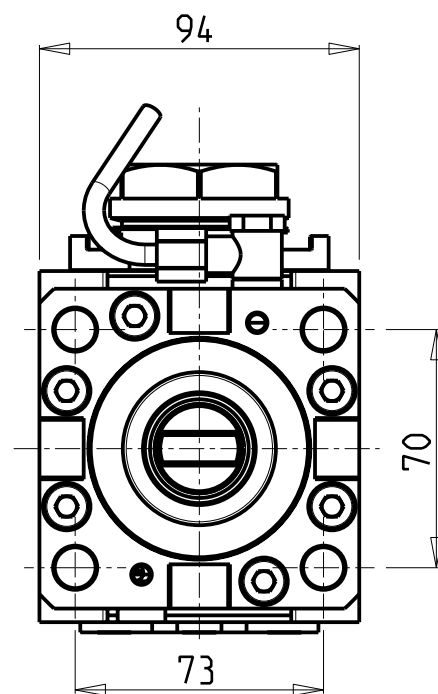
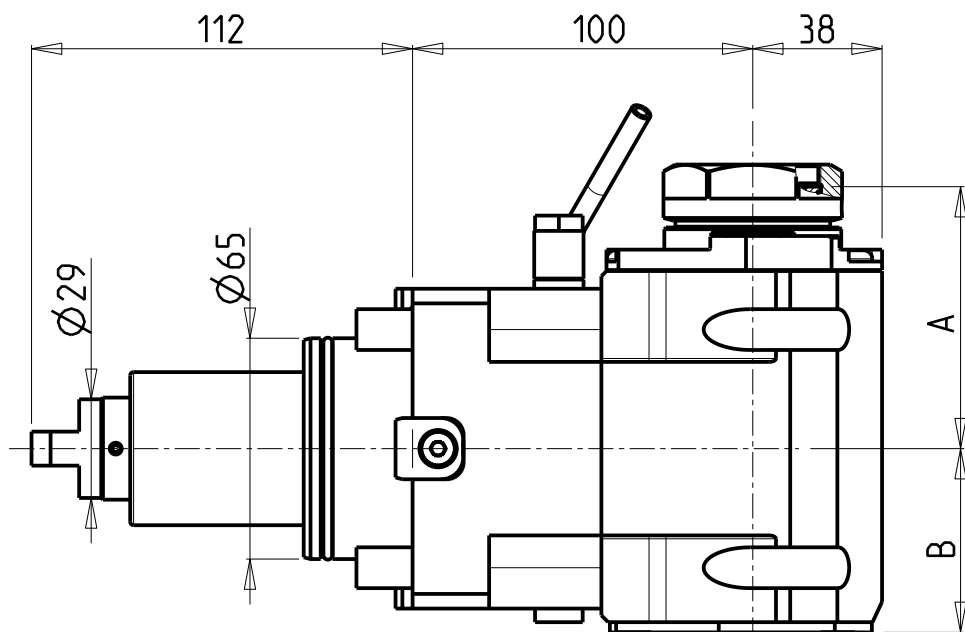

**ATTENZIONE - ATTENTION - ACHTUNG**

- VERIFICARE LE MISURE DI INGOMBRO PER POSSIBILE INTERFERENZA SU ALCUNI MODELLI DI MACCHINE
- Please check the overall sizes for possible interferences on some machine models
- Bitte überprüfen sie das ausmass um mögliche interferenzen auf einigen maschinen modellen zu vermeiden

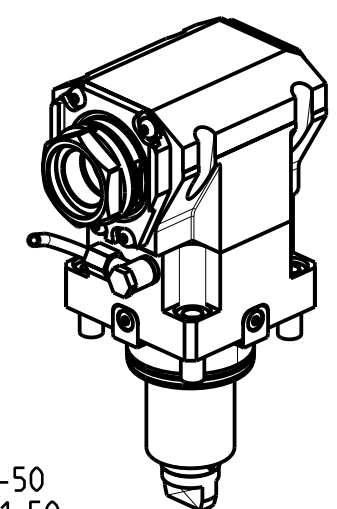

PER PORTAUTENSILI MODULARI MTSK-40 VEDI PAG. TBL300-1-40 E PER MTSK-50 VEDI PAG. TBL300-1-50  
 FOR MTSK-40 QUICK CHANGE TOOLHOLDERS CLAMPINGS SEE PAGE TBL300-1-40 AND FOR MTSK-50 SEE PAGE TBL300-1-50  
 FUER MTSK-40 MODULARE WERKZEUGAUFNAHMEN SIEHE SEITE TBL300-1-40 UND FUER MTSK-50 SIEHE SEITE TBL300-1-50

Cod. MT	Mandrino Spindle Spindel	I	RPM	Coppia Max Max Torque Max Drehmoment	Reversibile lato mandrino/contromandrino Reversible sub/main spindle side Umkehrbare Spindel-seite/ Gegenspindel-seite	Lubr.interna Coolant through Innenkuehlung	Lubr.esterna Ext. coolant Aussenkuehlung	A	B	CHIAVI NON INCLUSE Keys not included Schluessel nicht einbegriffen	
DW 01190140	MTSK-40	1:1	6000	100Nm	X	-	X	77	54	CHUB46	OKU0650004 •
DW 01190240	MTSK-40	1:1	6000	100Nm	X	P=70bar	X	77	65	CHUB46	OKU0650004 •
DW 01190150	MTSK-50	1:1	6000	100Nm	X	-	X	79	54	CHUB55	OKU0650004 •
DW 01190250	MTSK-50	1:1	6000	100Nm	X	P=70bar	X	79	65	CHUB55	OKU0650004 •

- Chiave inclusa
- Key included
- Schluessel inbegriffen

**SPINNER**

MOD: TC800 SMCY (BMT65)

MODULO MOTORIZZATO ASSIALE MTSK H=100mm

Axial MTSK driven tool H=100mm

Axial MTSK angetriebenes Werkzeug H=100mm

Subject to change without notice.

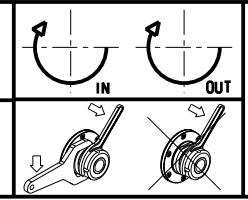

**M.T. srl**  
 Via Casino Albini 480  
 Tel. 0541/956034-957884  
 Fax 0541/956341  
 47842 S. GIOVANNI IN M. (RN)  
 e-mail: mtma@tmarchetti.com  
 http://www.tmmarchetti.com

PRODUZIONE MODULI ROTANTI



PAGINA SPN150-2-21-K

## CUSCINETTI MAGGIORATI PER LAVORAZIONI PESANTI

Reinforced bearings for  
heavy machining

Vergroesserte Lager fuer  
schwerere Bearbeitungen

### ATTENZIONE - ATTENTION - ACHTUNG

- VERIFICARE LE MISURE DI INGOMBRO PER POSSIBILE INTERFERENZA SU ALCUNI MODELLI DI MACCHINE
- Please check the overall sizes for possible interferences on some machine models
- Bitte überprüfen sie das ausmass um mögliche interferenzen auf einigen maschinen modellen zu vermeiden

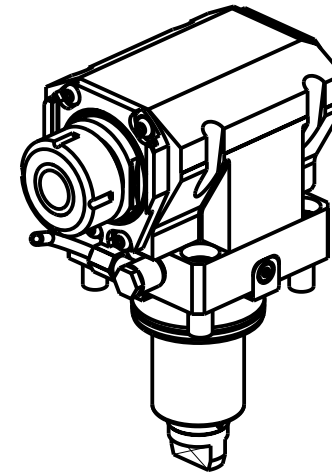
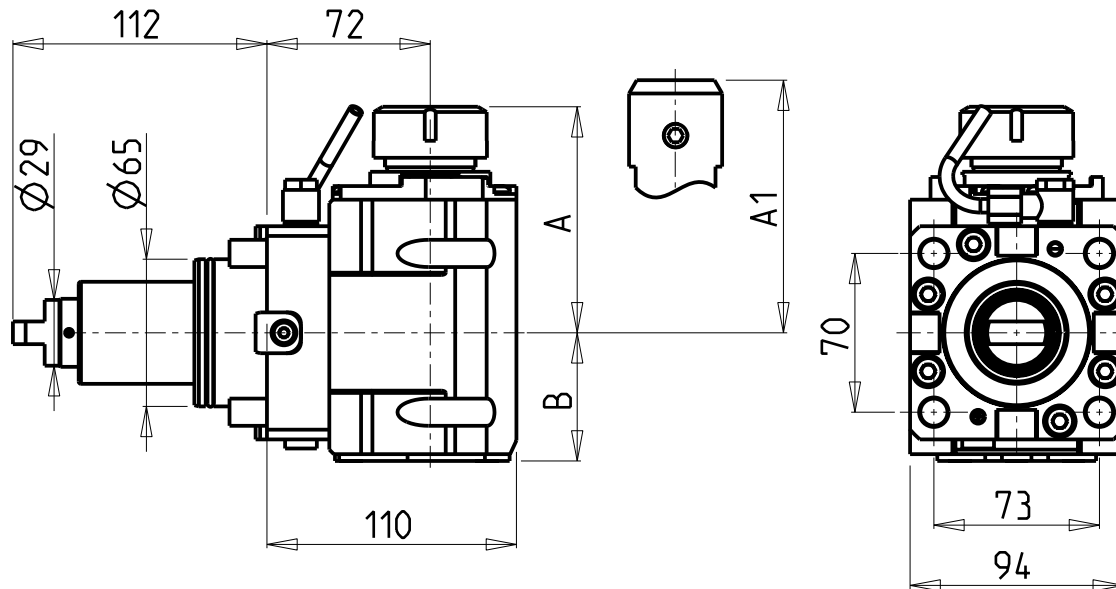

• Chiave inclusa

• Key included

• Schlüssel inbegriffen

Cod. MT	Mandrino Spindle Spindel	I	RPM	Coppia Max Max Torque Max Drehmoment	Reversibile lato mandrino/contromandrino Reversible sub/main spindle side Umkehrbare Spindel-seite/ Gegenspindel-seite	Lu-br.interna Coolant through Innenkuehlung	Lu-br.esterna Ext. coolant Aussenkuehlung	A	A1	B	CHIAVI NON INCLUDE Keys not included Schlüssel nicht einbegriffen	
DW02470132	ER32	1:1	6000	110Nm	X	-	X	99.7	-	56.5	CHSTER32	OKU0650004 ▪
DW02470232	ER32	1:1	6000	110Nm	X	P=70bar	X	99.7	-	67.5	CHSTER32	OKU0650004 ▪
DW02470725	WELDON25	1:1	6000	110Nm	X	-	X	-	106	56.5	-	-
DW02470825	WELDON25	1:1	6000	110Nm	X	P=70bar	X	-	106	67.5	-	-

SPINNER

MOD: TC800 SMCY (BMT65)

MODULO MOTORIZZATO ASSIALE MAGGIORATO H=72mm

Axial reinforced driven tool H=72mm

Axial angetriebenes Werkzeug vergroessert H=72mm

Subject to change without notice.

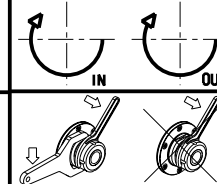

**M.T. srl**

Via Casino Albini 480  
Tel. 0541/956034-957884  
Fax 0541/956341  
47842 S. GIOVANNI IN M. (RN)  
e-mail: mtma@mtmarchetti.com  
http://www.mtmarchetti.com

PRODUZIONE MODULI ROTANTI



PAGINA SPN170-2-10

## CUSCINETTI MAGGIORATI PER LAVORAZIONI PESANTI

Reinforced bearings for  
heavy machining

Vergroesserte Lager fuer  
schwerere Bearbeitungen

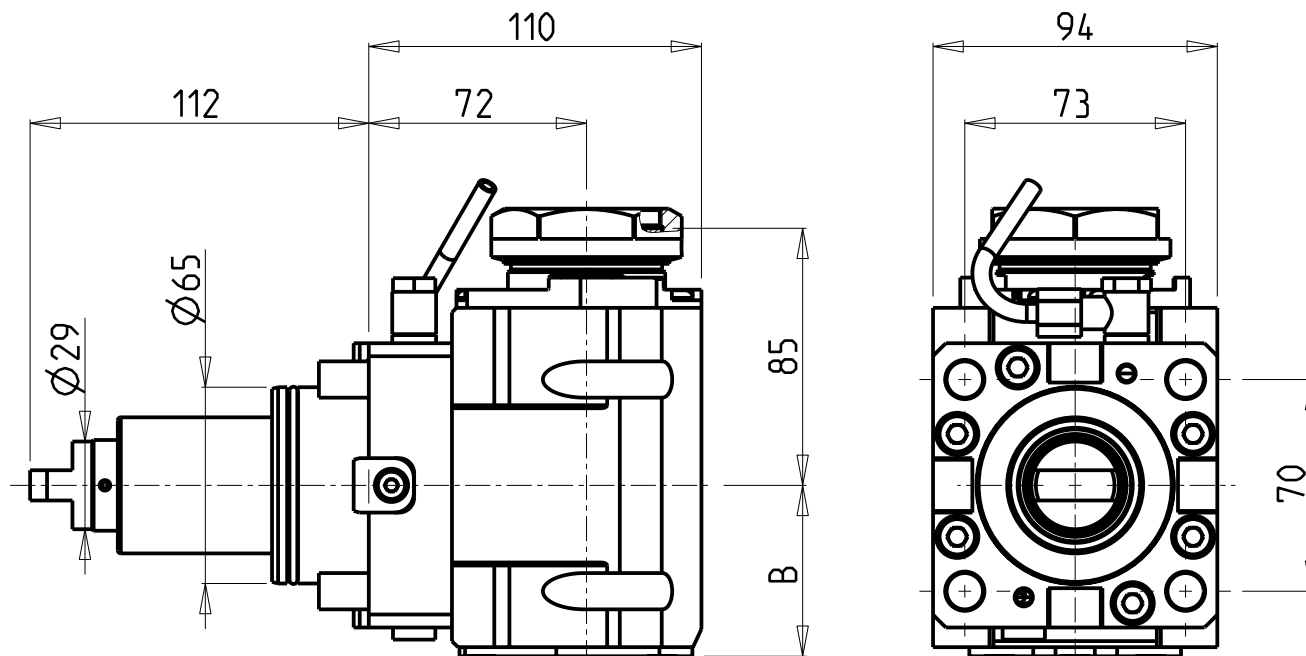
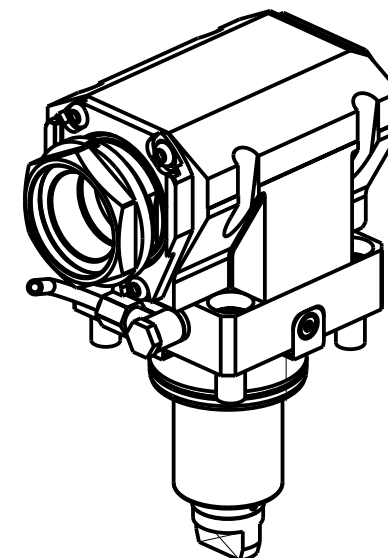

PER PORTAUTENSILI MODULARI MTSK-50 VEDI PAG. TBL300-1-50  
FOR MTSK-50 QUICK CHANGE TOOLHOLDERS CLAMPINGS SEE PAGE TBL300-1-50  
FUER MTSK-50 MODULARE WERKZEUGAUFNAHMEN SIEHE SEITE TBL300-1-50

Cod. MT	Mandrino Spindel Spindel	I	RPM	Coppia Max Max Torque Max Drehmoment	Reversibile lato mandrino/contromandrino Reversible sub/main spindle side Umkehrbare Spindel-seite/Gegenspindel-seite	Lubr.interna Coolant through Innenkuehlung	Lubr.esterna Ext. coolant Aussenkuehlung	B	CHIAVI NON INCLUSE Keys not included Schluessel nicht einbegriffen
DW02180150	MTSK-50	1:1	6000	110Nm	X	-	X	56.5	CHUB55 OKU0650004 *
DW02180250	MTSK-50	1:1	6000	110Nm	X	P=70bar	X	67.5	CHUB55 OKU0650004 *

- Chiave inclusa
- Key included
- Schluessel einbegriffen

SPINNER  
MOD: TC800 SMCY (BMT65)

MODULO MOTORIZZATO ASSIALE MAGGIORATO MTSK H=72mm  
Axial MTSK reinforced driven tool H=72mm  
Axial MTSK angetriebenes Werkzeug vergroessert H=72mm

Subject to change without notice.

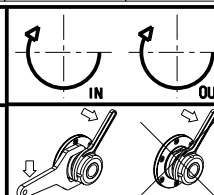

**M.T. srl**  
Via Casino Albini 480  
Tel. 0541/956034-957884  
Fax 0541/956341  
47842 S. GIOVANNI IN M. (RN)  
e-mail: mtma@mtmarchetti.com  
http://www.mtmarchetti.com

PRODUZIONE MODULI ROTANTI



PAGINA SPN170-2-10-K



## CUSCINETTI MAGGIORATI PER LAVORAZIONI PESANTI

Reinforced bearings for  
heavy machining

Vergroesserte Lager fuer  
schwerere Bearbeitungen

### ATTENZIONE - ATTENTION - ACHTUNG

- VERIFICARE LE MISURE DI INGOMBRO PER POSSIBILE INTERFERENZA SU ALCUNI MODELLI DI MACCHINE
- Please check the overall sizes for possible interferences on some machine models
- Bitte überprüfen sie das ausmass um mögliche interferenzen auf einigen maschinen modellen zu vermeiden

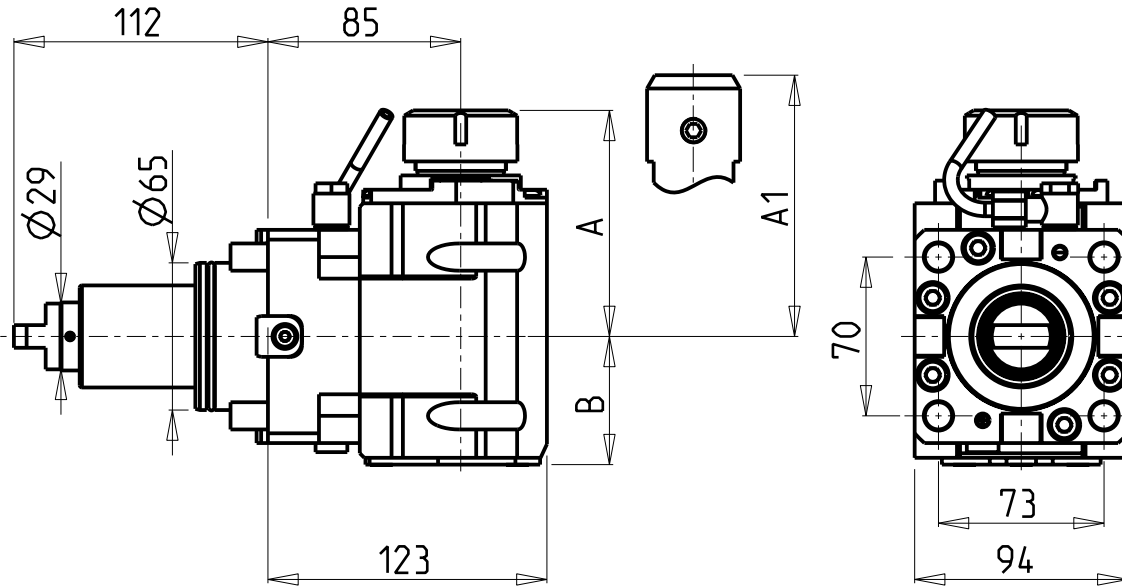

- Chiave inclusa
- Key included
- Schlüssel inbegriffen

Cod. MT	Mandrino Spindle Spindel	I	RPM	Coppia Max Max Torque Max Drehmoment	Reversibile lato mandrino/contromandrino Reversible sub/main spindle side Umkehrbare Spindel-seite/ Gegenspindel-seite	Lu-br.interna Coolant through Innenkuehlung	Lu-br.esterna Ext. coolant Aus-senkuehlung	A	A1	B	CHIAVI NON INCLUDE Keys not included Schlüssel nicht einbegriffen	
DW02480132	ER32	1:1	6000	110Nm	X	-	X	99.7	-	56.5	CHSTER32	OKU0650004
DW02480232	ER32	1:1	6000	110Nm	X	P=70bar	X	99.7	-	67.5	CHSTER32	OKU0650004
DW02480725	WELDON25	1:1	6000	110Nm	X	-	X	-	106	56.5	-	-
DW02480825	WELDON25	1:1	6000	110Nm	X	P=70bar	X	-	106	67.5	-	-

### SPINNER

MOD: TC800 SMCY (BMT65)

MODULO MOTORIZZATO ASSIALE MAGGIORATO H=85mm

Axial reinforced driven tool H=85mm

Axial angetriebenes Werkzeug vergroessert H=85mm

Subject to change without notice.

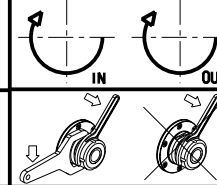

### M.T. srl

Via Casino Albini 480  
Tel. 0541/956034-957884  
Fax 0541/956341  
47842 S. GIOVANNI IN M. (RN)  
e-mail: mtma@mtmarchetti.com  
http://www.mtmarchetti.com

PRODUZIONE MODULI ROTANTI



PAGINA SPN170-2-20

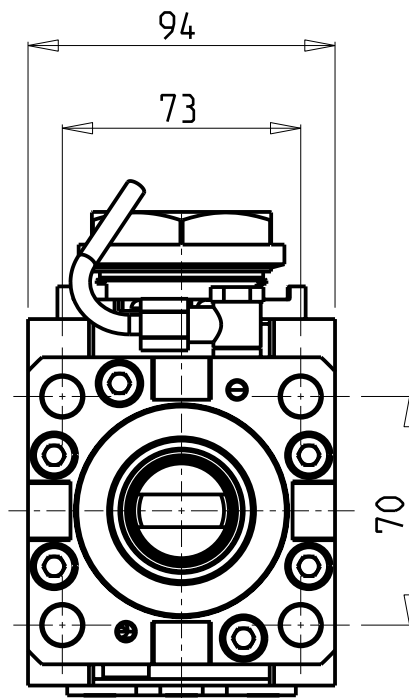
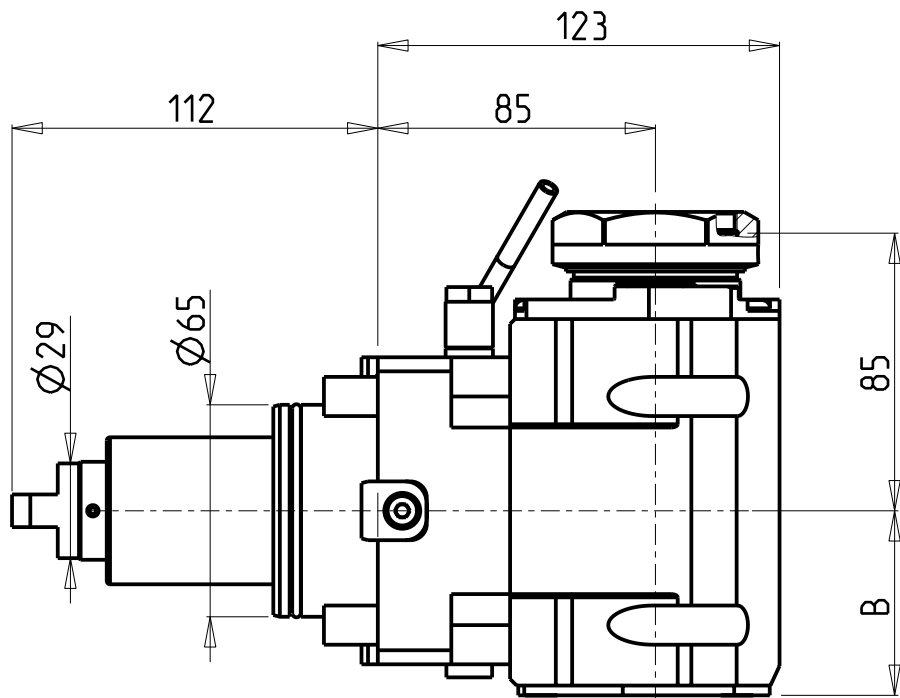

### CUSCINETTI MAGGIORATI PER LAVORAZIONI PESANTI

Reinforced bearings for  
heavy machining

Vergroesserte Lager fuer  
schwerere Bearbeitungen

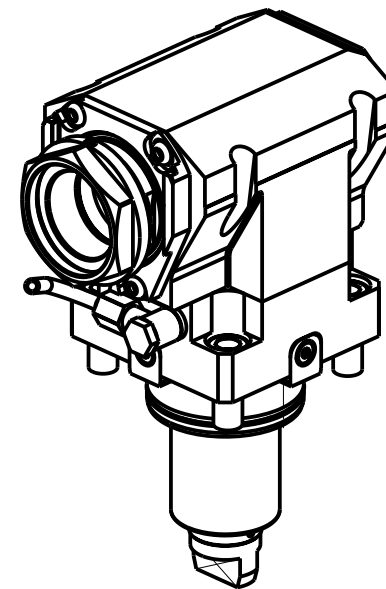

PER PORTAUTENSILI MODULARI MTSK-50 VEDI PAG. TBL300-1-50  
FOR MTSK-50 QUICK CHANGE TOOLHOLDERS CLAMPINGS SEE PAGE TBL300-1-50  
FUER MTSK-50 MODULARE WERKZEUGAUFNAHMEN SIEHE SEITE TBL300-1-50

Cod. MT	Mandrino Spindle Spindel	I	RPM	Coppia Max Max Torque Max Drehmoment	Reversibile lato mandrino/contromandrino Reversible sub/main spindle side Umkehrbare Spindel-seite/ Gegenspindel-seite	Lubr.interna Coolant through Innenkuehlung	Lubr.esterna Ext. coolant Aussenkuehlung	B	CHIAVI NON INCLUSE Keys not included Schluessel nicht einbegriffen	
DW 02190150	MTSK-50	1:1	6000	110Nm	X	-	X	56.5	CHUB55	OKU0650004 •
DW 02190250	MTSK-50	1:1	6000	110Nm	X	P=70bar	X	67.5	CHUB55	OKU0650004 •

- Chiave inclusa
- Key included
- Schluessel inbegriffen

### SPINNER

MOD: TC800 SMCY (BMT65)

MODULO MOTORIZZATO ASSIALE MAGGIORATO MTSK H=85mm

Axial MTSK reinforced driven tool H=85mm

Axial MTSK angetriebenes Werkzeug vergroessert H=85mm

Subject to change without notice.

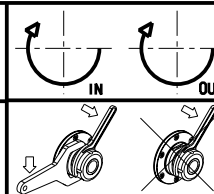

### M.T. srl

Via Casino Albini 480  
Tel. 0541/956034-957884  
Fax 0541/956341  
47842 S. GIOVANNI IN M. (RN)  
e-mail: mtma@mtmarchetti.com  
http://www.mtmarchetti.com

PRODUZIONE MODULI ROTANTI



PAGINA SPN170-2-20-K

## CUSCINETTI MAGGIORATI PER LAVORAZIONI PESANTI

Reinforced bearings for  
heavy machining

Vergroesserte Lager fuer  
schwerere Bearbeitungen

### ATTENZIONE - ATTENTION - ACHTUNG

- VERIFICARE LE MISURE DI INGOMBRO PER POSSIBILE INTERFERENZA SU ALCUNI MODELLI DI MACCHINE
- Please check the overall sizes for possible interferences on some machine models
- Bitte überprüfen sie das ausmass um mögliche interferenzen auf einigen maschinen modellen zu vermeiden

- Chiave inclusa
- Key included
- Schluessel inbegriffen

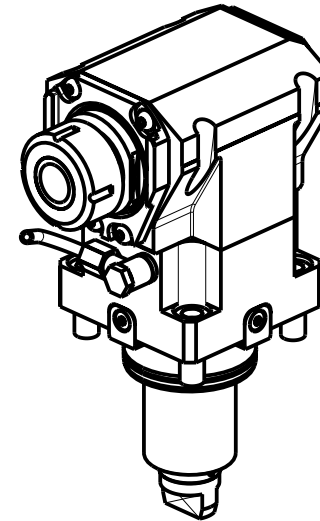
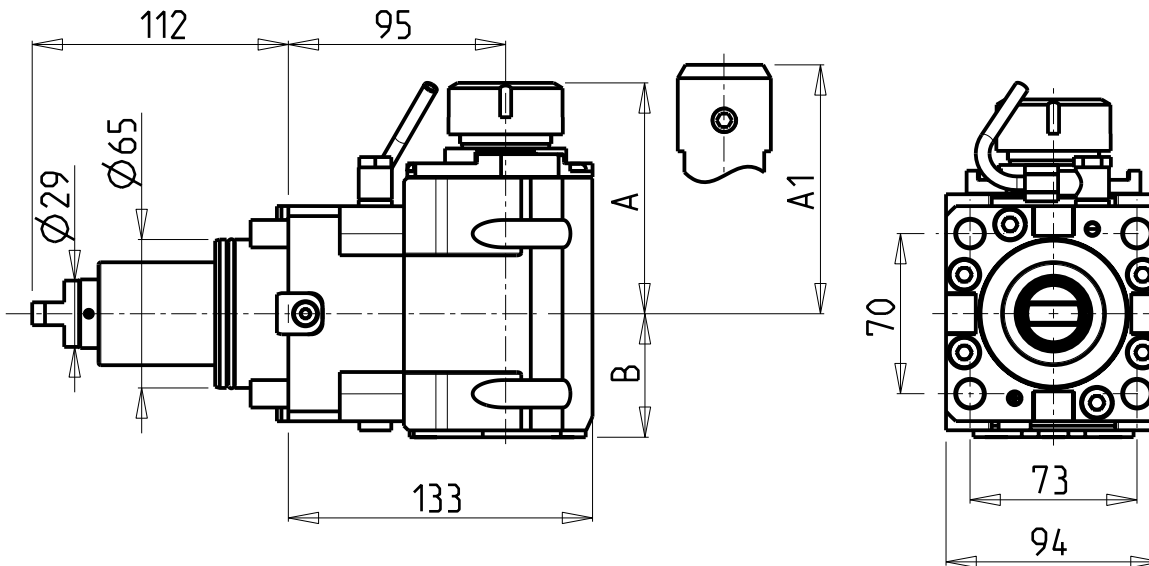

Cod. MT	Mandrino Spindle Spindel	I	RPM	Coppia Max Max Torque Max Drehmoment	Reversibile lato mandrino/contromandrino Reversible sub/main spindle side Umkehrbare Spindel-seite/ Gegenspindel-seite	Lu-br.interna Coolant through Innenkuehlung	Lu-br.esterna Ext. coolant Aussenkuehlung	A	A1	B	CHIAVI NON INCLUDE Keys not included Schluessel nicht einbegriffen	
DW 02500132	ER32	1:1	6000	110Nm	X	-	X	99.7	-	56.5	CHSTER32	OKU0650004
DW 02500232	ER32	1:1	6000	110Nm	X	P=70bar	X	99.7	-	67.5	CHSTER32	OKU0650004
DW 02500725	WELDON25	1:1	6000	110Nm	X	-	X	-	106	56.5	-	-
DW 02500825	WELDON25	1:1	6000	110Nm	X	P=70bar	X	-	106	67.5	-	-

SPINNER

MOD: TC800 SMCY (BMT65)

MODULO MOTORIZZATO ASSIALE MAGGIORATO H=95mm

Axial reinforced driven tool H=95mm

Axial angetriebenes Werkzeug vergroessert H=95mm

Subject to change without notice.

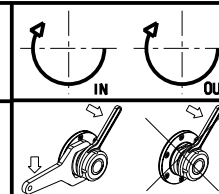

**M.T. srl**

Via Casino Albini 480  
Tel. 0541/956034-957884  
Fax 0541/956341  
47842 S. GIOVANNI IN M. (RN)  
e-mail: mtma@mtmarchetti.com  
http://www.mtmarchetti.com

PRODUZIONE MODULI ROTANTI



PAGINA SPN170-2-25

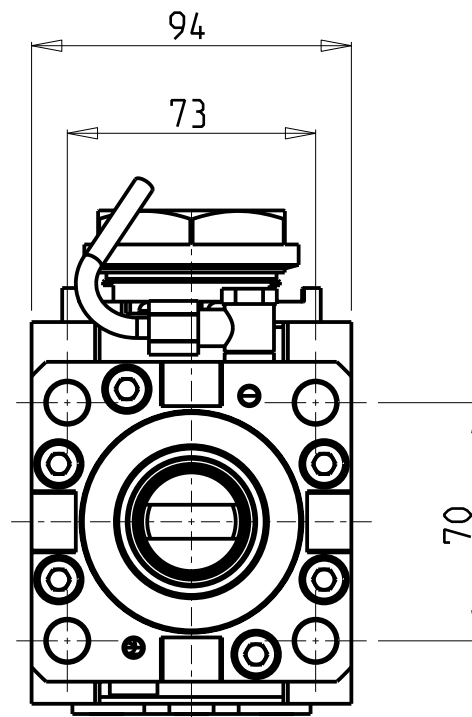
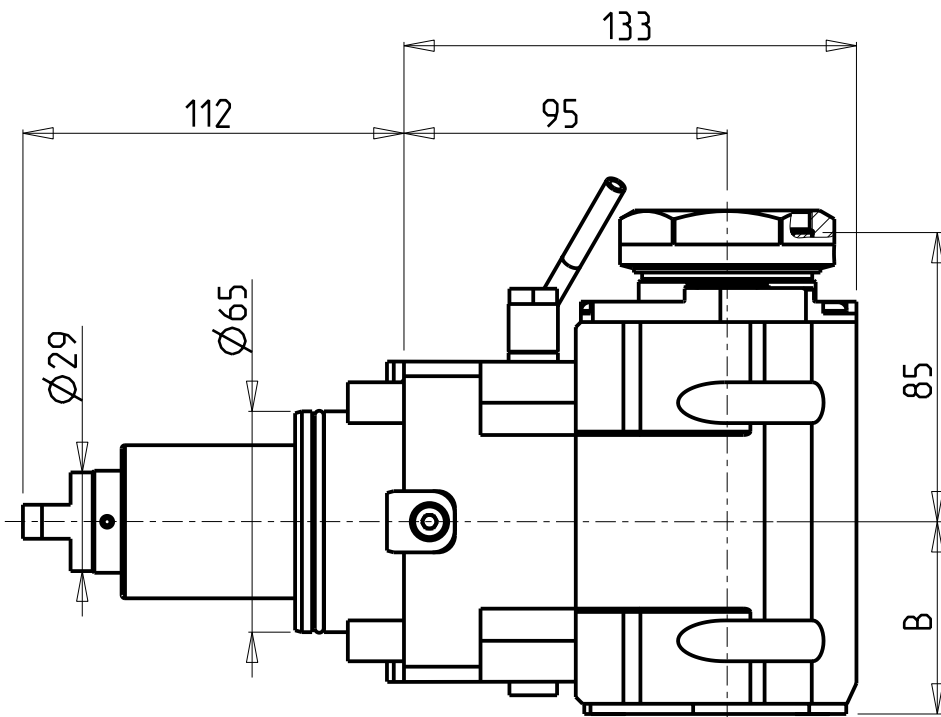

### CUSCINETTI MAGGIORATI PER LAVORAZIONI PESANTI

Reinforced bearings for  
heavy machining

Vergroesserte Lager fuer  
schwerere Bearbeitungen

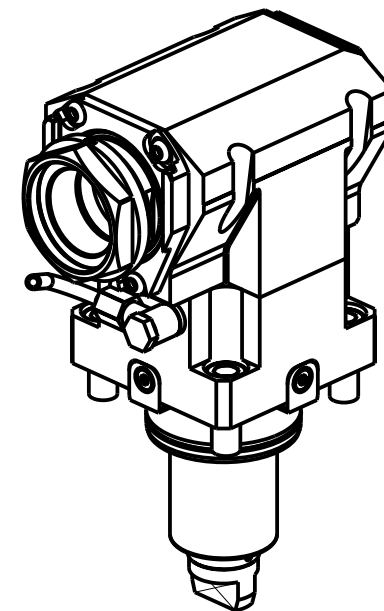

- Chiave inclusa
- Key included
- Schluessel inbegriffen

PER PORTAUTENSILI MODULARI MTSK-50 VEDI PAG. TBL300-1-50  
FOR MTSK-50 QUICK CHANGE TOOLHOLDERS CLAMPINGS SEE PAGE TBL300-1-50  
FUER MTSK-50 MODULARE WERKZEUGAUFNAHMEN SIEHE SEITE TBL300-1-50

Cod. MT	Mandrino Spindle Spindel	I	RPM	Coppia Max Max Torque Max Drehmoment	Reversibile lato mandrino/contromandrino Reversible sub/main spindle side Umkehrbare Spindel-seite/ Gegenspindel-seite	Lubr.interna Coolant through Innenkuehlung	Lubr.esterna Ext. coolant Aussenkuehlung	B	CHIAVI NON INCLUSE Keys not included Schluessel nicht einbegriffen	
DW 02540150	MTSK-50	1:1	6000	110Nm	X	-	X	56.5	CHUB55	OKU0650004 •
DW 02540250	MTSK-50	1:1	6000	110Nm	X	P=70bar	X	67.5	CHUB55	OKU0650004 •

SPINNER  
MOD: TC800 SMCY (BMT65)

MODULO MOTORIZZATO ASSIALE MAGGIORATO MTSK H=95mm  
Axial MTSK reinforced driven tool H=95mm  
Axial MTSK angetriebenes Werkzeug vergroessert H=95mm

Subject to change without notice.

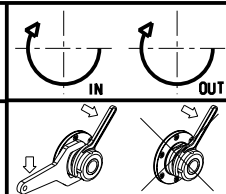

**M.T. srl**  
Via Casino Albini 480  
Tel. 0541/956034-957884  
Fax 0541/956341  
47842 S. GIOVANNI IN M. (RN)  
e-mail: mtma@mtmarchetti.com  
http://www.mtmarchetti.com

PRODUZIONE MODULI ROTANTI



PAGINA SPN170-2-25-K

## CUSCINETTI MAGGIORATI PER LAVORAZIONI PESANTI

Reinforced bearings for  
heavy machining

Vergroesserte Lager fuer  
schwerere Bearbeitungen

### ATTENZIONE - ATTENTION - ACHTUNG

- VERIFICARE LE MISURE DI INGOMBRO PER POSSIBILE INTERFERENZA SU ALCUNI MODELLI DI MACCHINE
- Please check the overall sizes for possible interferences on some machine models
- Bitte überprüfen sie das ausmass um mögliche interferenzen auf einigen maschinen modellen zu vermeiden

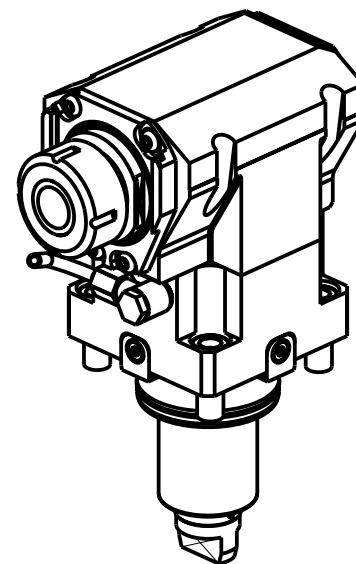
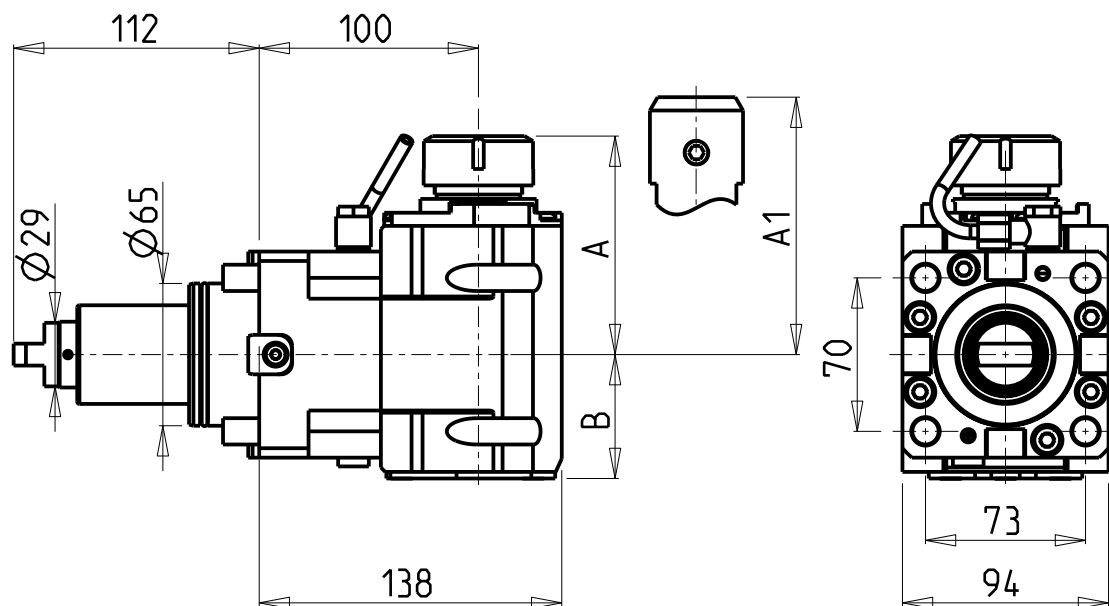

• Chiave inclusa

• Key included

• Schlüssel inbegriffen

Cod. MT	Mandrino Spindle Spindel	I	RPM	Coppia Max Max Torque Max Drehmoment	Reversibile lato mandrino/contromandrino Reversible sub/main spindle side Umkehrbare Spindel-seite/ Gegenspindel-seite	Lubr.interna Coolant through Innenkuehlung	Lubr.esterna Ext. coolant Aussenkuehlung	A	A1	B	CHIAVI NON INCLUDE Keys not included Schlüssel nicht einbegriffen	
DW 02490132	ER32	1:1	6000	110Nm	X	-	X	99.7	-	56.5	CHSTER32	OKU0650004 ▪
DW 02490232	ER32	1:1	6000	110Nm	X	P=70bar	X	99.7	-	67.5	CHSTER32	OKU0650004 ▪
DW 02490725	WELDON25	1:1	6000	110Nm	X	-	X	-	106	56.5	-	-
DW 02490825	WELDON25	1:1	6000	110Nm	X	P=70bar	X	-	106	67.5	-	-

SPINNER

MOD: TC800 SMCY (BMT65)

MODULO MOTORIZZATO ASSIALE MAGGIORATO H=100mm

Axial reinforced driven tool H=100mm

Axial angetriebenes Werkzeug vergroessert H=100mm

Subject to change without notice.

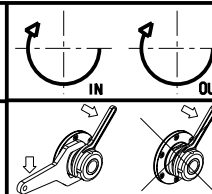

**M.T. srl**

Via Casino Albini 480  
Tel. 0541/956034-957884

Fax 0541/956341

47842 S. GIOVANNI IN M. (RN)

e-mail: mtma@mtmarchetti.com

http://www.mtmarchetti.com

PRODUZIONE MODULI ROTANTI



PAGINA SPN170-2-30

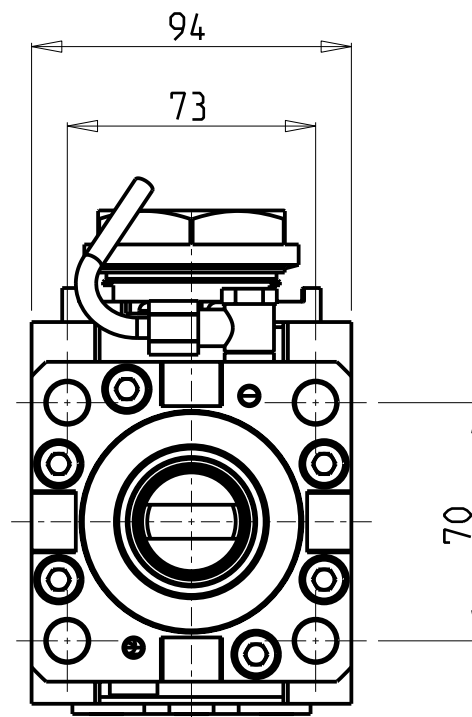
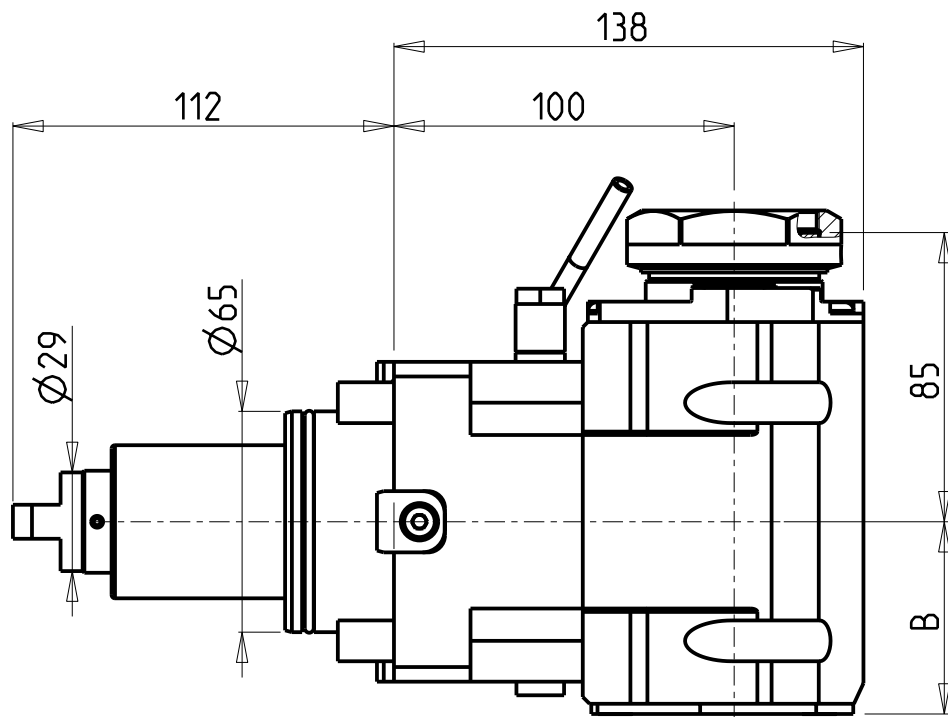

### CUSCINETTI MAGGIORATI PER LAVORAZIONI PESANTI

Reinforced bearings for  
heavy machining

Vergroesserte Lager fuer  
schwerere Bearbeitungen

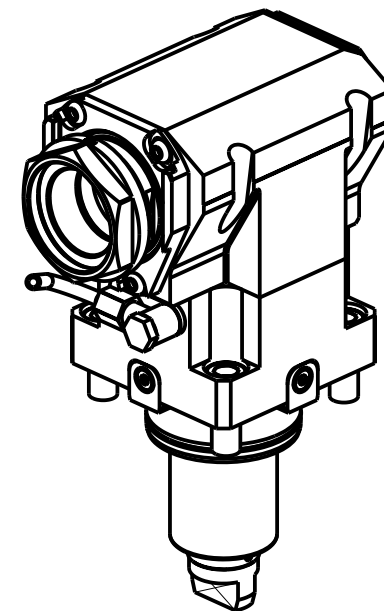

- Chiave inclusa
- Key included
- Schluessel inbegriffen

PER PORTAUTENSILI MODULARI MTSK-50 VEDI PAG. TBL300-1-50  
FOR MTSK-50 QUICK CHANGE TOOLHOLDERS CLAMPINGS SEE PAGE TBL300-1-50  
FUER MTSK-50 MODULARE WERKZEUGAUFNAHMEN SIEHE SEITE TBL300-1-50

Cod. MT	Mandrino Spindle Spindel	I	RPM	Coppia Max Max Torque Max Drehmoment	Reversibile lato mandrino/contromandrino Reversible sub/main spindle side Umkehrbare Spindel-seite/ Gegenspindel-seite	Lu-br.interna Coolant through Innenkuehlung	Lu-br.esterna Ext. coolant Aussenkuehlung	B	CHIAVI NON INCLUDE Keys not included Schluessel nicht einbegriffen
DW02200150	MTSK-50	1:1	6000	110Nm	X	-	X	56.5	CHUB55 OKU0650004 *
DW02200250	MTSK-50	1:1	6000	110Nm	X	P=70bar	X	67.5	CHUB55 OKU0650004 *

SPINNER  
MOD: TC800 SMCY (BMT65)

MODULO MOTORIZZATO ASSIALE MAGGIORATO MTSK H=100mm  
Axial MTSK reinforced driven tool H=100mm  
Axial MTSK angetriebenes Werkzeug vergroessert H=100mm

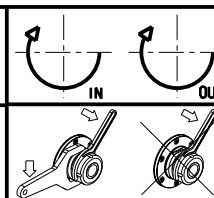

**M.T. srl**  
Via Casino Albini 480  
Tel. 0541/956034-957884  
Fax 0541/956341  
47842 S. GIOVANNI IN M. (RN)  
e-mail: mtma@mtmarchetti.com  
http://www.mtmarchetti.com

PRODUZIONE MODULI ROTANTI



PAGINA SPN170-2-30-K

Subject to change without notice.

10/2018

**ATTENZIONE - ATTENTION - ACHTUNG**

- VERIFICARE LE MISURE DI INGOMBRO PER POSSIBILE INTERFERENZA SU ALCUNI MODELLI DI MACCHINE
- Please check the overall sizes for possible interferences on some machine models
- Bitte überprüfen sie das ausmass um mögliche interferenzen auf einigen maschinen modellen zu vermeiden

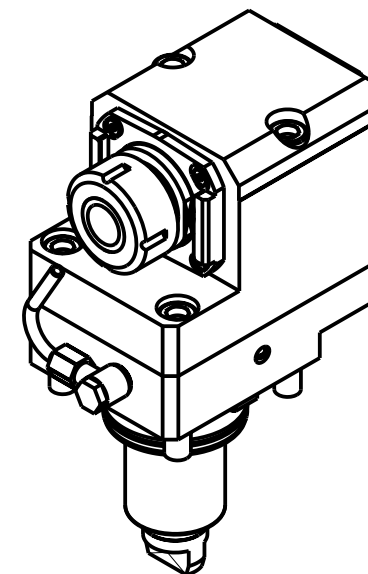
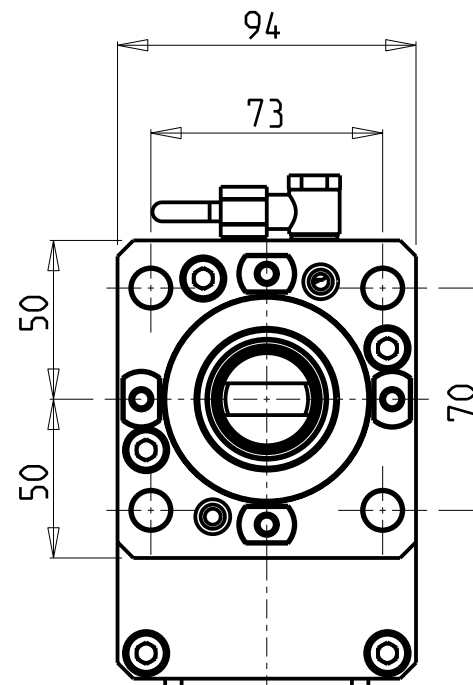
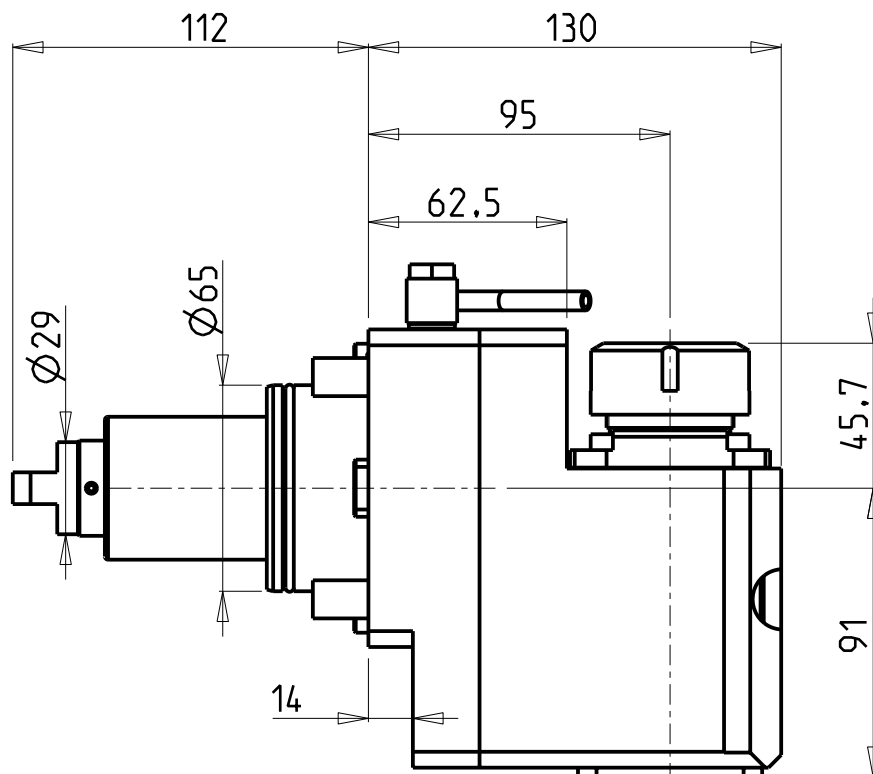

- Chiave inclusa
- Key included
- Schlüssel inbegriffen

Cod. MT	Mandrino Spindle Spindel	I	RPM	Coppia Max Max Torque Max Drehmoment	Reversibile lato mandrino/contromandrino Reversible sub/main spindle side Umkehrbare Spindel-seite/ Gegenspindel-seite	Lubrificazione est. Ext. coolant Auslenkuehlung	CHIAVI NON INCLUSE Keys not included Schlüssel nicht einbegriffen	CHSTER32	MNZ0410005 • NEW
DW 02570132	ER32	1:1	6000	70Nm	X	X			

**SPINNER**  
MOD: TC800 SMCY (BMT65)

MODULO MOTORIZZATO ASSIALE ARRETRATO H=95mm  
Axial rear-set driven tool H=95mm  
Axial angetriebenes Werkzeug zurueckversetzt H=95mm

Subject to change without notice.

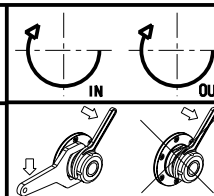

**M.T. srl**  
Via Casino Albini 480  
Tel. 0541/956034-957884  
Fax 0541/956341  
47842 S. GIOVANNI IN M. (RN)  
e-mail: mtma@mtmarchetti.com  
http://www.mtmarchetti.com

PRODUZIONE MODULI ROTANTI



PAGINA SPN180-2-25

## ATTENZIONE - ATTENTION - ACHTUNG

- VERIFICARE LE MISURE DI INGOMBRO PER POSSIBILE INTERFERENZA SU ALCUNI MODELLI DI MACCHINE
- Please check the overall sizes for possible interferences on some machine models
- Bitte überprüfen sie das ausmass um mögliche interferenzen auf einigen maschinen modellen zu vermeiden

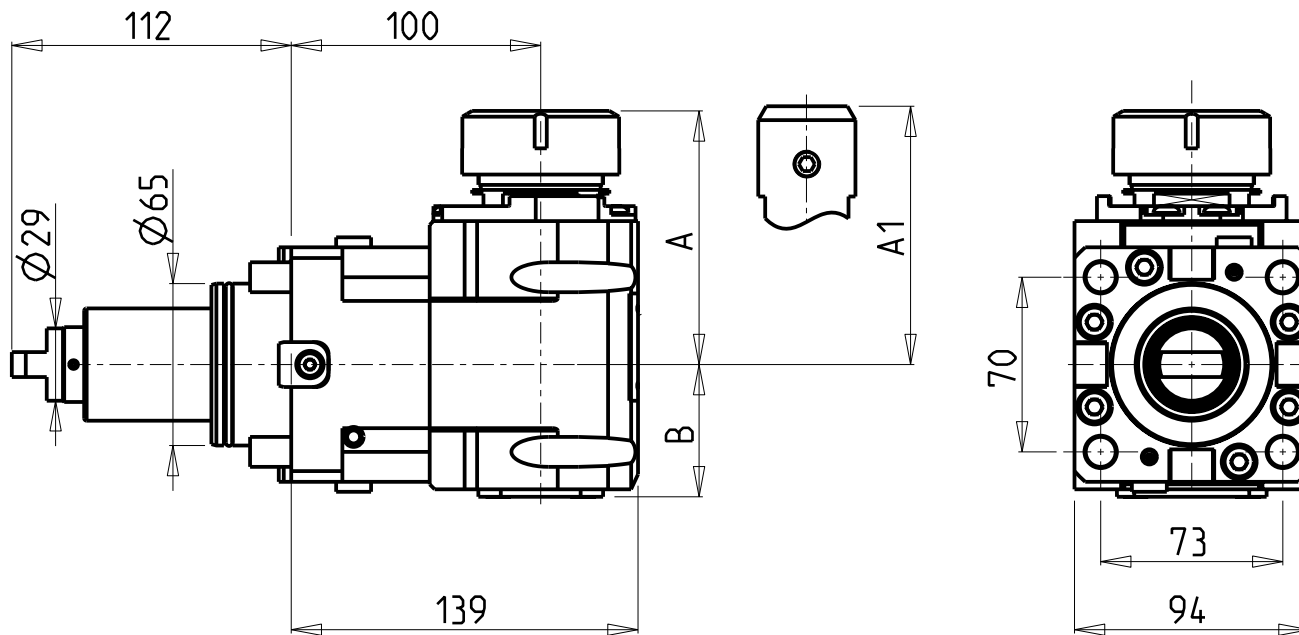

- Chiave inclusa
- Key included
- Schluessel inbegriffen

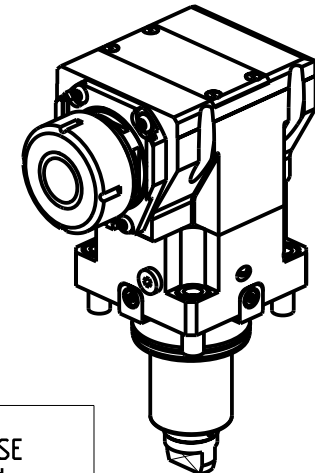

Cod. MT	Mandrino Spindle Spindel	I	RPM	Coppia Max Max Torque Max Drehmoment	Reversibile lato mandrino/contromandrino Reversible sub/main spindle side Umkehrbare Spindel-seite/ Gegenspindel-seite	Lubr.interna Coolant through Innenkuehlung	Lubr.esterna Ext. coolant Aussenkuehlung	A	A1	B	CHIAVI NON INCLUDE Keys not included Schluessel nicht einbegriffen	
DW 02360132	ER32	2:1	3000	130Nm	X	-	X	98.7	-	53	OKU0650004	CHSTER32
DW 02360232	ER32	2:1	3000	130Nm	X	P=70bar	X	98.7	-	66.5	OKU0650004	CHSTER32
DW 02360140	ER40	2:1	3000	130Nm	X	-	X	101.7	-	53	OKU0650004	CHSTER40
DW 02360240	ER40	2:1	3000	130Nm	X	P=70bar	X	101.7	-	66.5	OKU0650004	CHSTER40
DW 02360725	WELDON 25	2:1	3000	130Nm	X	-	X	-	106	53	-	-
DW 02360825	WELDON 25	2:1	3000	130Nm	X	P=70bar	X	-	106	66.5	-	-

### SPINNER

MOD: TC800 SMCY (BMT65)

MODULO MOTORIZZATO ASSIALE RIDOTTO I=2:1 H=100mm

Axial geared-down I=2:1 driven tool H=100mm

Axial angetriebenes Werkzeug untersetzt I=2:1 H=100mm

Subject to change without notice.

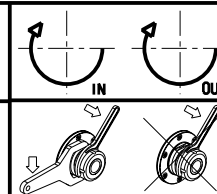

### M.T. srl

Via Casino Albini 480  
Tel. 0541/956034-957884  
Fax 0541/956341  
47842 S. GIOVANNI IN M. (RN)  
e-mail: mtma@mtmarchetti.com  
http://www.mtmarchetti.com

PRODUZIONE MODULI ROTANTI



PAGINA SPN190-2-30



**ATTENZIONE - ATTENTION - ACHTUNG**

- VERIFICARE LE MISURE DI INGOMBRO PER POSSIBILE INTERFERENZA SU ALCUNI MODELLI DI MACCHINE
- Please check the overall sizes for possible interferences on some machine models
- Bitte überprüfen sie das ausmass um mögliche interferenzen auf einigen maschinen modellen zu vermeiden

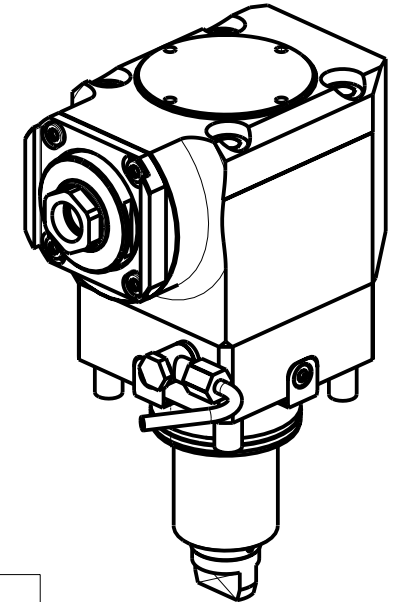
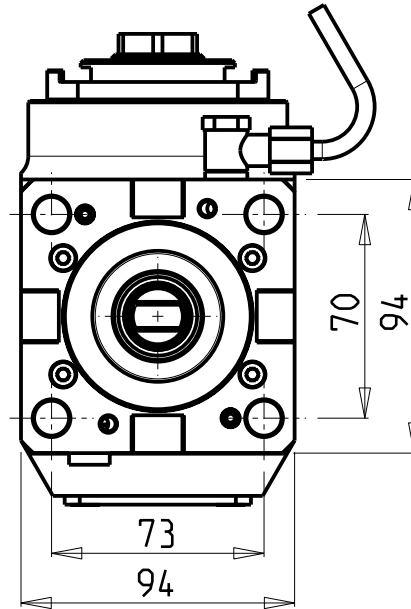
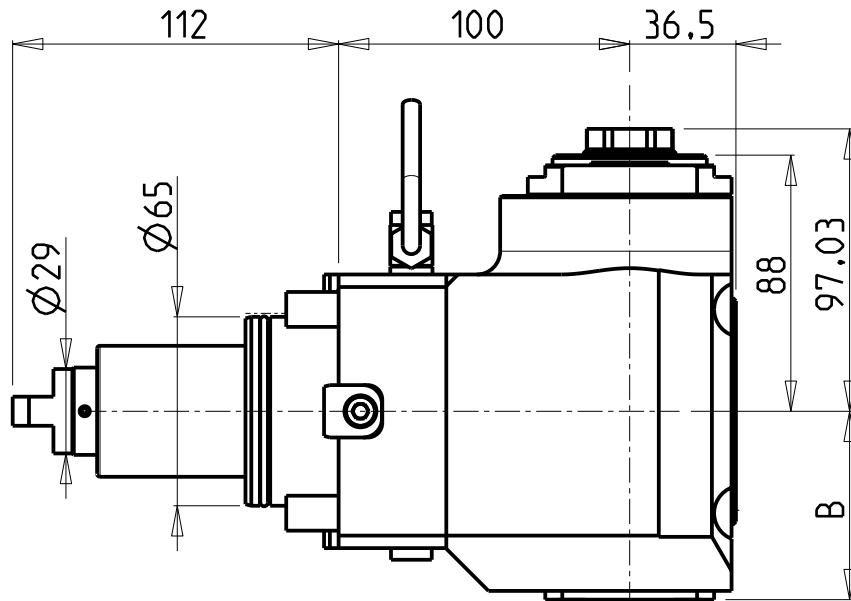

- Chiave inclusa
- Key included
- Schlüssel inbegriffen

Cod. MT	Mandrino Spindle Spindel	I	RPM	Coppia Max Max Torque Max Drehmoment	Reversibile lato mandrino/contromandrino Reversible sub/main spindle side Umkehrbare Spindel-seite/ Gegenspindel-seite	Lubrificazione int. Coolant through Innenkuehlung	Lubrificazione est. Ext. coolant Aussenkuehlung	B	CHIAVI NON INCLUSE Keys not included Schlüssel nicht einbegriffen	
DW 00710125	ER A 25	1:2	12000	30Nm	X		X	64.7	OKU0650004	CHUB27
DW 00710225	ER A 25	1:2	12000	30Nm	X	P=70bar	X	73.2	OKU0650004	CHUB27

**SPINNER**

MOD: TC800 SMCY (BMT65)

MODULO MOTORIZZATO ASSIALE MOLTIPLICATO I=1:2

Axial geared-up I=1:2 driven tool

Axial angetriebenes Werkzeug uebersetzt I=1:2

Subject to change without notice.

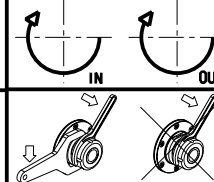

**M.T. srl**

Via Casino Albini 480  
Tel. 0541/956034-957884  
Fax 0541/956341  
47842 S. GIOVANNI IN M. (RN)  
e-mail: mtma@mtmarchetti.com  
http://www.mtmarchetti.com

PRODUZIONE MODULI ROTANTI



PAGINA SPN200-2-20

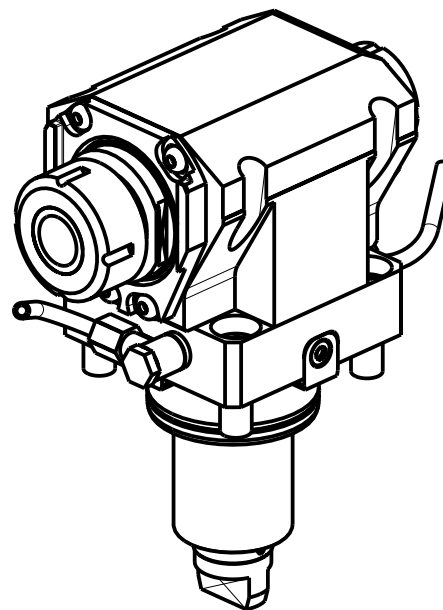
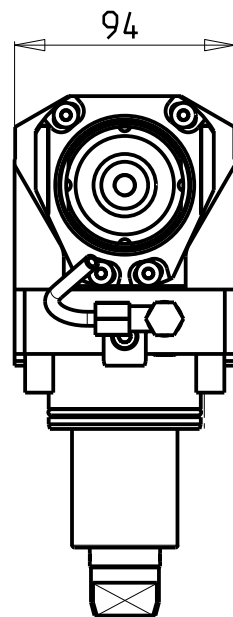
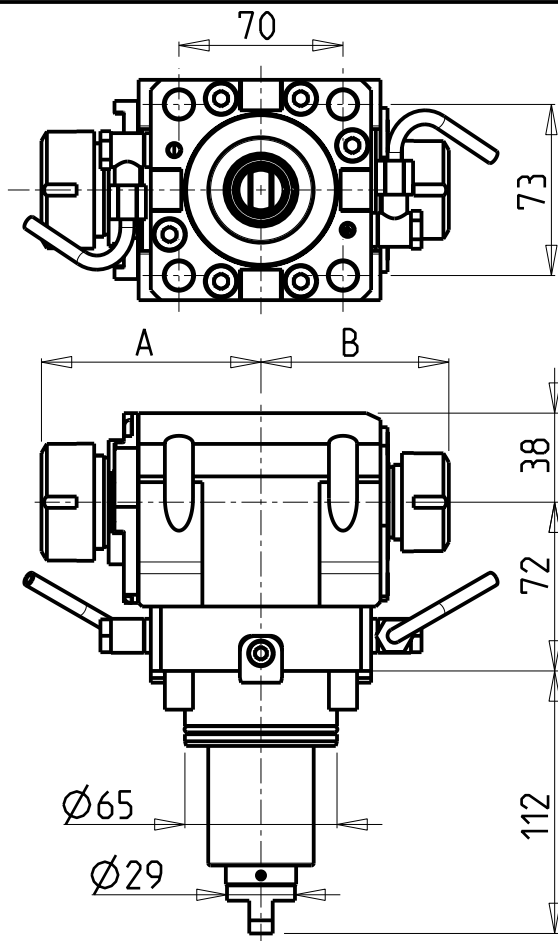

### ATTENZIONE - ATTENTION - ACHTUNG

- Per lo smontaggio degli utensili utilizzare sempre la chiave di contrasto come indicato nel manuale d'uso.
- For disassembly of the tools use always the contrast key as mentioned in the user instructions.
- Fuer das Abmontieren der Werkzeuge immer den Gegenschlüssel benutzen wie in der Bedienungsanleitung erwaeht.

• Chiave inclusa

• Key included

• Schlüssel inbegriffen

Cod. MT	Mandrino Spindle Spindel	I	RPM	Coppia Max Max Torque Max Drehmoment	Reversibile lato mandrino/contromandrino Reversible sub/main spindle side Umkehrbare Spindel-seite/ Gegenspindel-seite	Lubrificazione est. Ext. coolant Aussenkuehlung	A	B	CHIAVI NON INCLUSE Keys not included Schlüssel nicht einbegriffen					
DW00720132	ER32+ER25	1:1	6000	100Nm	X	X	93.66	80.16	CHSTER32	CHSTER25	OKU0650004	-	-	
DW00722520	ERA25+ERA20	1:1	6000	100Nm	X	X	65	55.5	CHUB22	CHUB27	OKU0650004	CHTAER20ZC	CHTAER25ZC	

SPINNER

MOD: TC800 SMCY (BMT65)

MODULO MOTORIZZATO ASSIALE BISPORGENTE H=72mm

Axial opposite face driven tool H=72mm

Axial angetriebenes Werkzeug halb vorspringend H=72mm

Subject to change without notice.

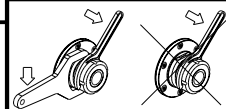

**M.T. srl**

Via Casino Albini 480  
Tel. 0541/956034-957884  
Fax 0541/956341

47842 S. GIOVANNI IN M. (RN)  
e-mail: mtma@mtmarchetti.com  
http://www.mtmarchetti.com

PRODUZIONE MODULI ROTANTI



PAGINA SPN240-2-10

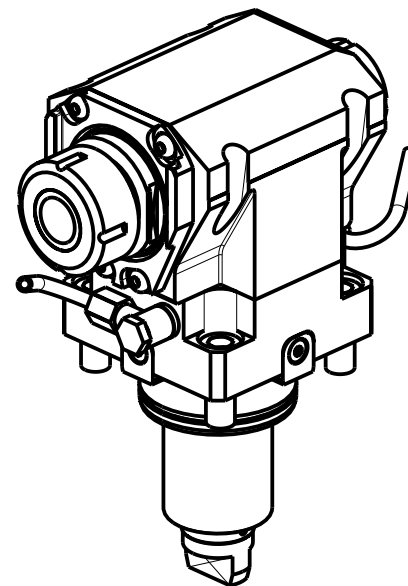
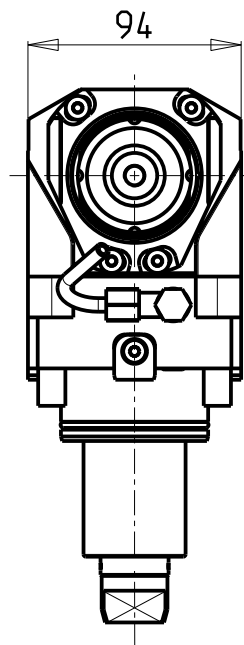
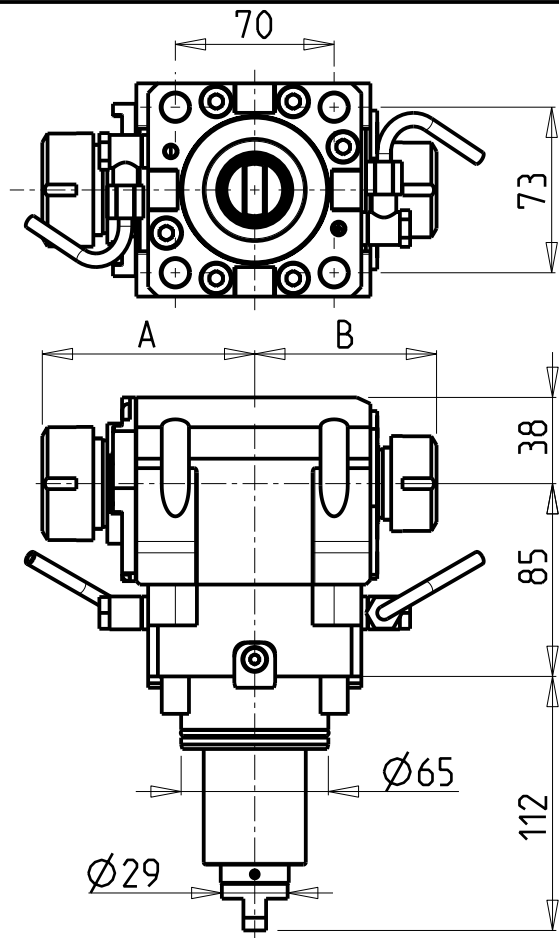

### ATTENZIONE - ATTENTION - ACHTUNG

- Per lo smontaggio degli utensili utilizzare sempre la chiave di contrasto come indicato nel manuale d'uso.
- For disassembly of the tools use always the contrast key as mentioned in the user instructions.
- Fuer das Abmontieren der Werkzeuge immer den Gegenschlüssel benutzen wie in der Bedienungsanleitung erwaeht.

• Chiave inclusa

• Key included

• Schlüssel inbegriffen

Cod. MT	Mandrino Spindle Spindel	I	RPM	Coppia Max Max Torque Max Drehmoment	Reversibile lato mandrino/contromandrino Reversible sub/main spindle side Umkehrbare Spindel-seite/ Gegenspindel-seite	Lubrificazione est. Ext. coolant Aussenkuehlung	A	B	CHIAVI NON INCLUSE Keys not included Schlüssel nicht einbegriffen					
DW 01150132	ER32+ER25	1:1	6000	100Nm	X	X	93.66	80.16	CHSTER32	CHSTER25	OKU0650004	-	-	
DW 01152520	ERA25+ERA20	1:1	6000	100Nm	X	X	65	55.5	CHUB22	CHUB27	OKU0650004	CHTAER20ZC	CHTAER25ZC	

### SPINNER

MOD: TC800 SMCY (BMT65)

MODULO MOTORIZZATO ASSIALE BISPORGENTE H=85mm

Axial opposite face driven tool H=85mm

Axial angetriebenes Werkzeug halb vorspringend H=85mm

Subject to change without notice.

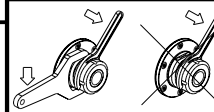

### M.T. srl

Via Casino Albini 480  
Tel. 0541/956034-957884  
Fax 0541/956341  
47842 S. GIOVANNI IN M. (RN)  
e-mail: mtma@mtmarchetti.com  
http://www.mtmarchetti.com

PRODUZIONE MODULI ROTANTI



PAGINA SPN240-2-15

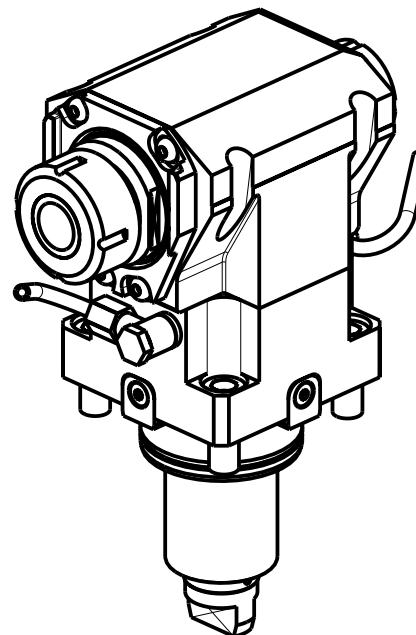
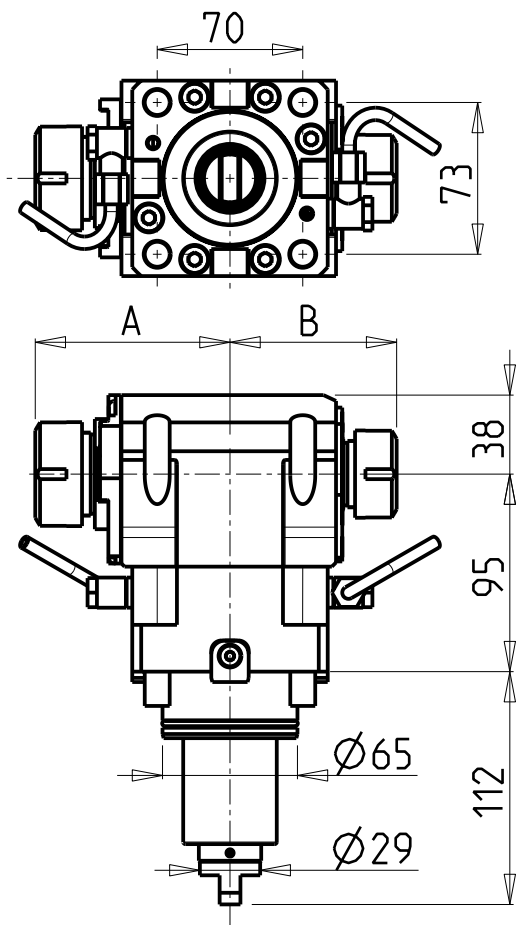

### ATTENZIONE - ATTENTION - ACHTUNG

- Per lo smontaggio degli utensili utilizzare sempre la chiave di contrasto come indicato nel manuale d'uso.
- For disassembly of the tools use always the contrast key as mentioned in the user instructions.
- Fuer das Abmontieren der Werkzeuge immer den Gegenschlüssel benutzen wie in der Bedienungsanleitung erwaeht.

### ATTENZIONE - ATTENTION - ACHTUNG

- VERIFICARE LE MISURE DI INGOMBRO PER POSSIBILE INTERFERENZA SU ALCUNI MODELLI DI MACCHINE
- Please check the overall sizes for possible interferences on some machine models
- Bitte ueberpruefen sie das ausmass um moegliche interferenzen auf einigen maschinen modellen zu vermeiden

- Chiave inclusa
- Key included
- Schluessel inbegriffen

CHIAVI NON INCLUSE  
Keys not included  
Schluessel nicht einbegriffen

Cod. MT	Mandrino Spindle Spindel	I	RPM	Coppia Max Max Torque Max Drehmoment	Reversibile lato mandrino/contromandrino Reversible sub/main spindle side Umkehrbare Spindel-seite/ Gegenspindel-seite	Lubrificazione est. Ext. coolant Aussenkuehlung	A	B					
DW 02520132	ER32+ER25	1:1	6000	100Nm	X	X	93.7	80.2	CHSTER32	CHSTER25	OKU0650004	-	-
DW 02522520	ERA25+ERA20	1:1	6000	100Nm	X	X	65	55.5	CHUB22	CHUB27	OKU0650004	CHTAER20ZC	CHTAER25ZC

## SPINNER

MOD: TC800 SMCY (BMT65)

MODULO MOTORIZZATO ASSIALE BISPORGENTE H=95mm

Axial opposite face driven tool H=95mm

Axial angetriebenes Werkzeug halb vorspringend H=95mm

Subject to change without notice.

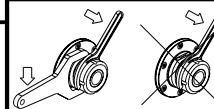

### M.T. srl

Via Casino Albini 480  
Tel. 0541/956034-957884  
Fax 0541/956341  
47842 S. GIOVANNI IN M. (RN)  
e-mail: mtma@mtmarchetti.com  
http://www.mtmarchetti.com

PRODUZIONE MODULI ROTANTI



PAGINA SPN240-2-18

**ATTENZIONE - ATTENTION - ACHTUNG**

- Per lo smontaggio degli utensili utilizzare sempre la chiave di contrasto come indicato nel manuale d'uso.
- For disassembly of the tools use always the contrast key as mentioned in the user instructions.
- Fuer das Abmontieren der Werkzeuge immer den Gegenschlüssel benutzen wie in der Bedienungsanleitung erwaeht.

**ATTENZIONE - ATTENTION - ACHTUNG**

- VERIFICARE LE MISURE DI INGOMBRO PER POSSIBILE INTERFERENZA SU ALCUNI MODELLI DI MACCHINE
- Please check the overall sizes for possible interferences on some machine models
- Bitte überprüfen sie das ausmass um mögliche interferenzen auf einigen maschinen modellen zu vermeiden

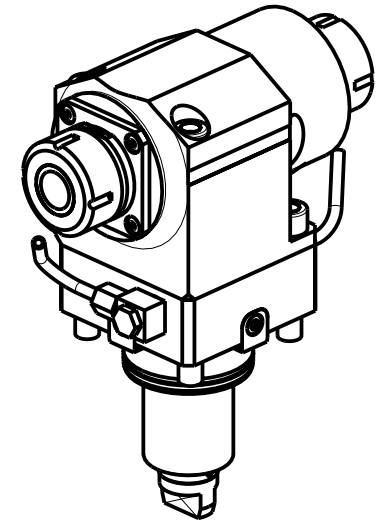
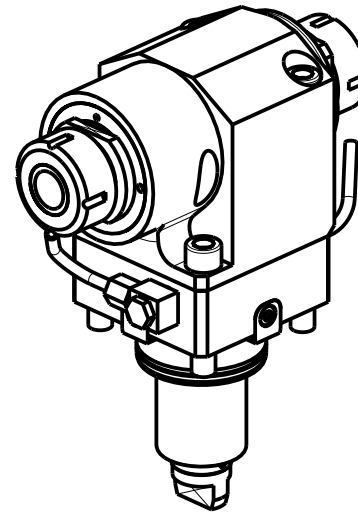
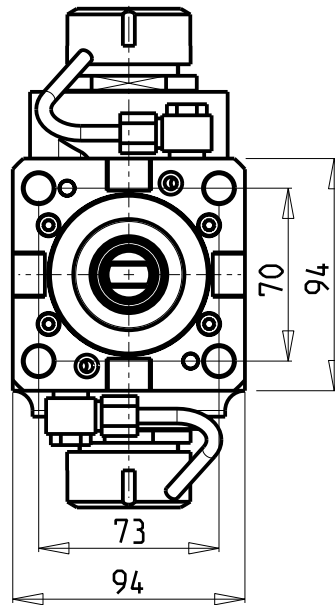
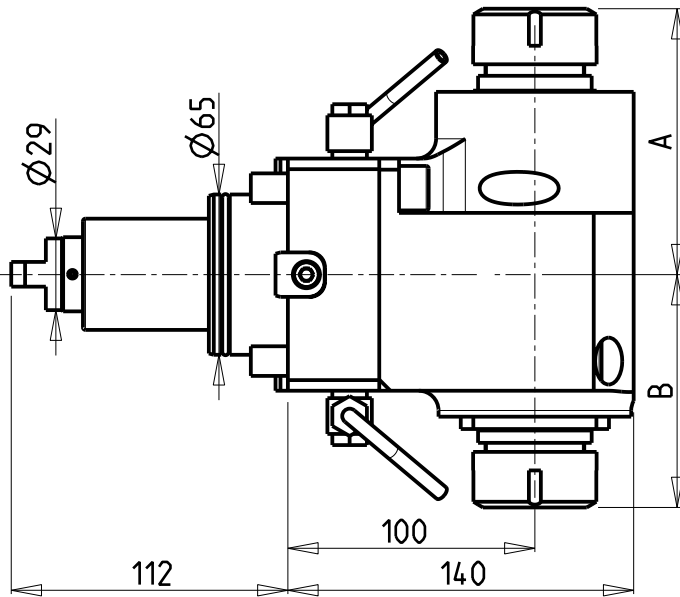

Cod. MT	Mandrino Spindle Spindel	I	RPM	Coppia Max Max Torque Max Drehmoment	Reversibile lato mandrino/contromandrino Reversible sub/main spindle side Umkehrbare Spindelseite/ Gegenspindelseite	Lubrificazione est. Ext. coolant Aussenkuehlung	A	B	CHIAVI NON INCLUSE Keys not included Schlüssel nicht einbegriffen		
									CHSTER32	CHUB46	
DW 00070232	ER32+ER32	1:1	6000	100Nm	X	X	107.66	94.26	CHSTER32	CHUB46	
DW 00073225	ERA25+ERA32	1:1	6000	100Nm	X	X	106.03	81.13	CHUB27	CHUB32	CHUB46

**SPINNER**

MOD: TC800 SMCY (BMT65)

MODULO MOTORIZZATO ASSIALE BISPORGENTE H=100mm

Axial opposite face twin driven tool H=100mm

Axial angetriebenes Werkzeug halb vorspringend H=100mm

Subject to change without notice.

**M.T. srl**

Via Casino Albini 480  
Tel. 0541/956034-957884  
Fax 0541/956341  
47842 S. GIOVANNI IN M. (RN)  
e-mail: mtma@mtmarchetti.com  
http://www.mtmarchetti.com

PRODUZIONE MODULI ROTANTI



PAGINA SPN240-2-20

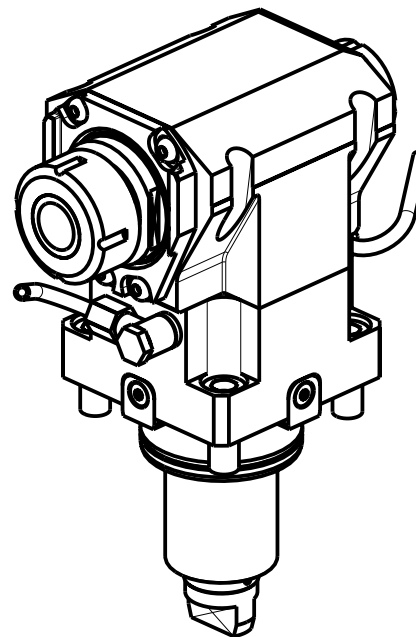
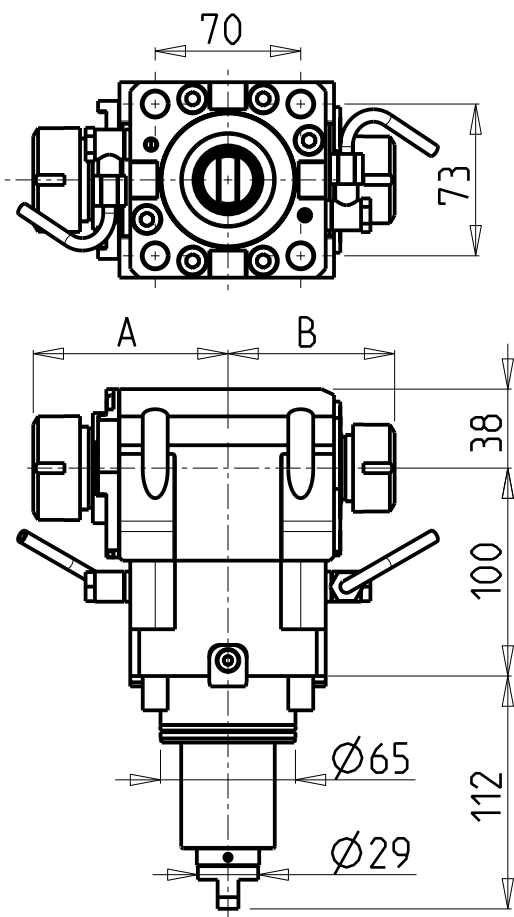

### ATTENZIONE - ATTENTION - ACHTUNG

- Per lo smontaggio degli utensili utilizzare sempre la chiave di contrasto come indicato nel manuale d'uso.
- For disassembly of the tools use always the contrast key as mentioned in the user instructions.
- Fuer das Abmontieren der Werkzeuge immer den Gegenschlüssel benutzen wie in der Bedienungsanleitung erwaeht.

### ATTENZIONE - ATTENTION - ACHTUNG

- VERIFICARE LE MISURE DI INGOMBRO PER POSSIBILE INTERFERENZA SU ALCUNI MODELLI DI MACCHINE
- Please check the overall sizes for possible interferences on some machine models
- Bitte ueberpruefen sie das ausmass um moegliche interferenzen auf einigen maschinen modellen zu vermeiden

• Chiave inclusa

• Key included

• Schluessel inbegriffen

CHIAVI NON INCLUSE  
Keys not included  
Schluessel nicht einbegriffen

Cod. MT	Mandrino Spindle Spindel	I	RPM	Coppia Max Max Torque Max Drehmoment	Reversibile lato mandrino/contromandrino Reversible sub/main spindle side Umkehrbare Spindel-seite/ Gegenspindel-seite	Lubrificazione est. Ext. coolant Aussenkuehlung	A	B					
DW 01160132	ER32+ER25	1:1	6000	100Nm	X	X	93.66	80.16	CHSTER32	CHSTER25	OKU0650004	-	-
DW 01162520	ERA25+ERA20	1:1	6000	100Nm	X	X	65	55.5	CHUB22	CHUB27	OKU0650004	CHTAER20ZC	CHTAER25ZC

### SPINNER

MOD: TC800 SMCY (BMT65)

MODULO MOTORIZZATO ASSIALE BISPORGENTE H=100mm

Axial opposite face driven tool H=100mm

Axial angetriebenes Werkzeug halb vorspringend H=100mm

Subject to change without notice.

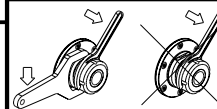

### M.T. srl

Via Casino Albini 480  
Tel. 0541/956034-957884  
Fax 0541/956341  
47842 S. GIOVANNI IN M. (RN)  
e-mail: mtma@mtmarchetti.com  
http://www.mtmarchetti.com

PRODUZIONE MODULI ROTANTI



PAGINA SPN240-2-21

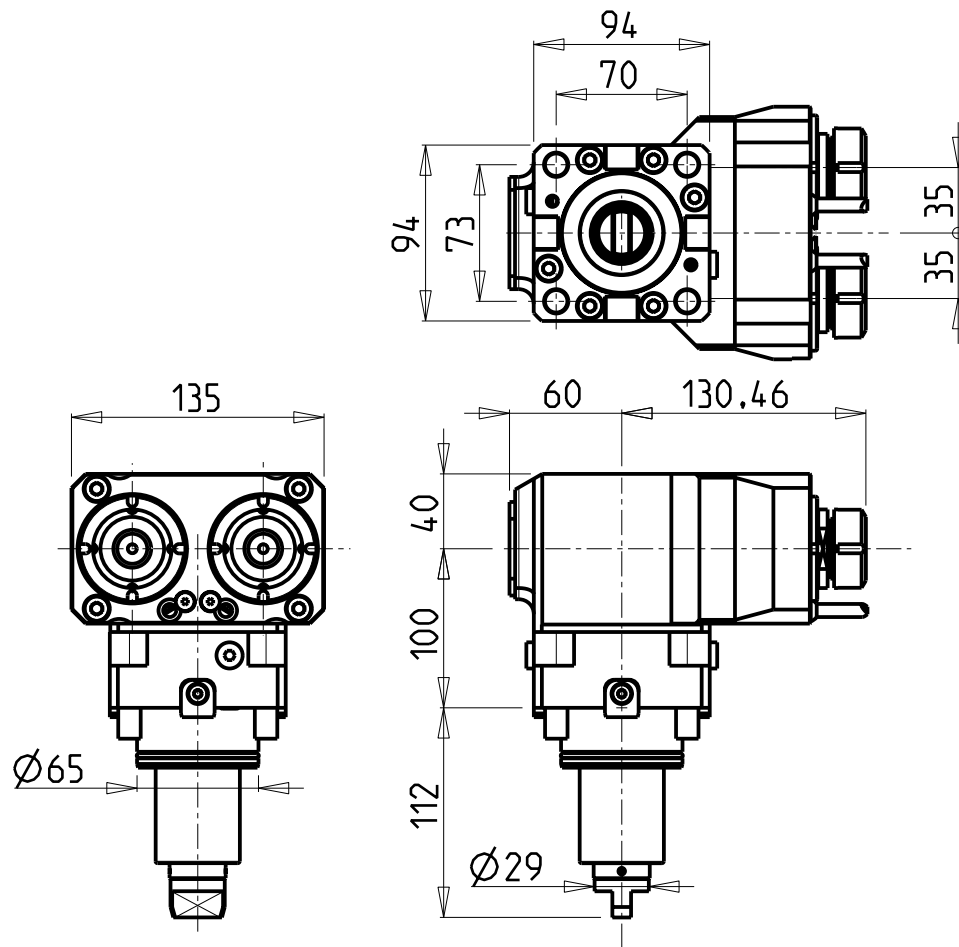

### ATTENZIONE - ATTENTION - ACHTUNG

- Per lo smontaggio degli utensili utilizzare sempre la chiave di contrasto come indicato nel manuale d'uso.
- For disassembly of the tools use always the contrast key as mentioned in the user instructions.
- Fuer das Abmontieren der Werkzeuge immer den Gegenschlüssel benutzen wie in der Bedienungsanleitung erwäehnt.

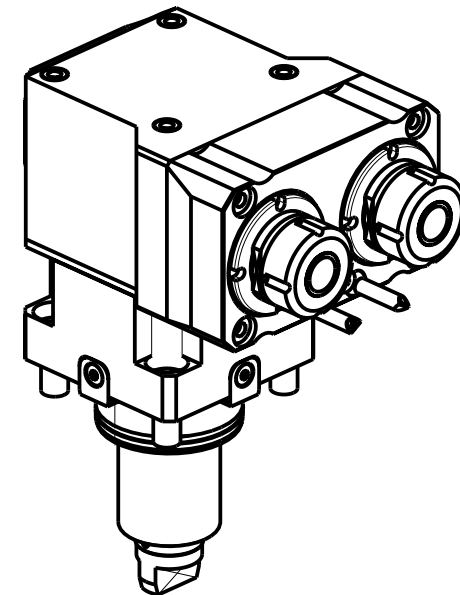

Cod. MT	Mandrino Spindle Spindel	I	RPM	Coppia Max Max Torque Max Drehmoment	Reversibile lato mandrino/contromandrino Reversible sub/main spindle side Umkehrbare Spindel-seite/ Gegenspindel-seite	Lubrificazione est. Ext. coolant Aussenkuehlung	CHIAVI NON INCLUSE Keys not included Schluessel nicht einbegriffen	
DW01230225	ER25	1:1	6000	40Nm	X	X	CHUB36	CHSTER25

SPINNER  
MOD: TC800 SMCY (BMT65)

MODULO MOTORIZZATO ASSIALE 2 USCITE IN Y H=100mm  
Axial single side twin head driven tool in Y H=100mm  
Axial angetriebenes Werkzeug 2 Ausgaenge in Y H=100mm

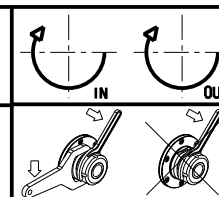

**M.T. srl**  
Via Casino Albini 480  
Tel. 0541/956034-957884  
Fax 0541/956341  
47842 S. GIOVANNI IN M. (RN)  
e-mail: mtma@mtmarchetti.com  
http://www.mtmarchetti.com

PRODUZIONE MODULI ROTANTI



PAGINA SPN260-2-30

Subject to change without notice.

10/2018

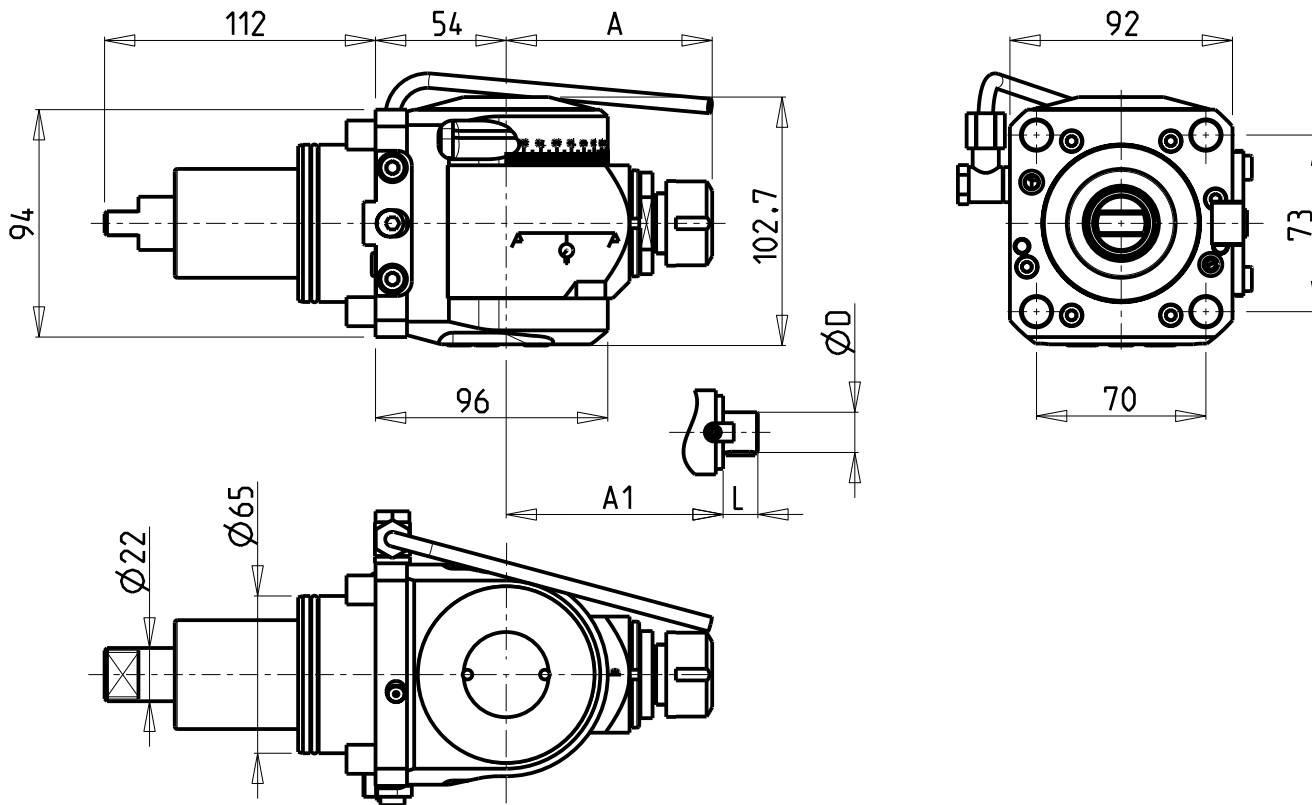

### ATTENZIONE - ATTENTION - ACHTUNG

- VERIFICARE LE MISURE DI INGOMBRO PER POSSIBILE INTERFERENZA SU ALCUNI MODELLI DI MACCHINE
- Please check the overall sizes for possible interferences on some machine models
- Bitte überprüfen sie das ausmass um mögliche interferenzen auf einigen maschinen modellen zu vermeiden

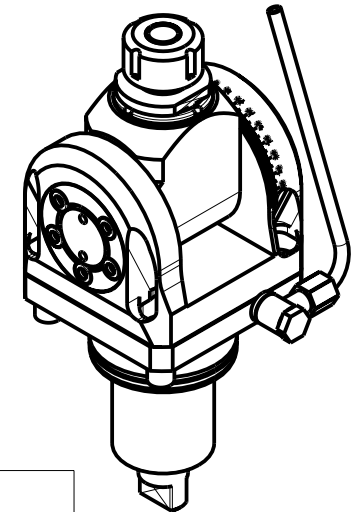

Cod. MT	Mandrino Spindle Spindel	I	RPM	Coppia Max Max Torque Max Drehmoment	Reversibile lato mandrino/contromandrino Reversible sub/main spindle side Umkehrbare Spindelseite/ Gegenspindelseite	Lubrificazione est. Ext. coolant Aussehenkuehlung	A	A1	D	L	CHIAVI INCLUSE Keys included Schlüssel inbegriffen		
											CH_VTCROCE_M08	CHUB36	CHESL10
DW 01920120	ER20	1:1	6000	40Nm	X	X	85.16	-	-	-	CHSTER20	CHUB36	CHESL10
DW 01920125	ER25	1:1	6000	40Nm	X	X	86.16	-	-	-	CHSTER25	CHUB36	CHESL10
DW 01920516	Ø16x17	1:1	6000	40Nm	X	X	-	65	16	17	CH_VTCROCE_M08	CHUB36	CHESL10
DW 01920522	Ø22x19	1:1	6000	40Nm	X	X	-	66	22	19	CH_VTCROCE_M10	CHUB36	CHESL10
DW 01920519	Ø3/4"x3/4"	1:1	6000	40Nm	X	X	-	65	3/4"	3/4"	CH_VTCROCE_M08	CHUB36	CHESL10

### SPINNER

MOD: TC800 SMCY (BMT65)

MODULO MOTORIZZATO ORIENTABILE ±90° H=54mm

±90° adjustable angle driven tool H=54mm

Angetriebenes Werkzeug schwenkbar ±90° H=54mm

Subject to change without notice.

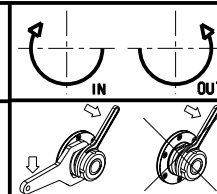

### M.T. srl

Via Casino Albini 480  
Tel. 0541/956034-957884  
Fax 0541/956341  
47842 S. GIOVANNI IN M. (RN)  
e-mail: mtma@mtmarchetti.com  
http://www.mtmarchetti.com

PRODUZIONE MODULI ROTANTI



PAGINA SPN333-2-00



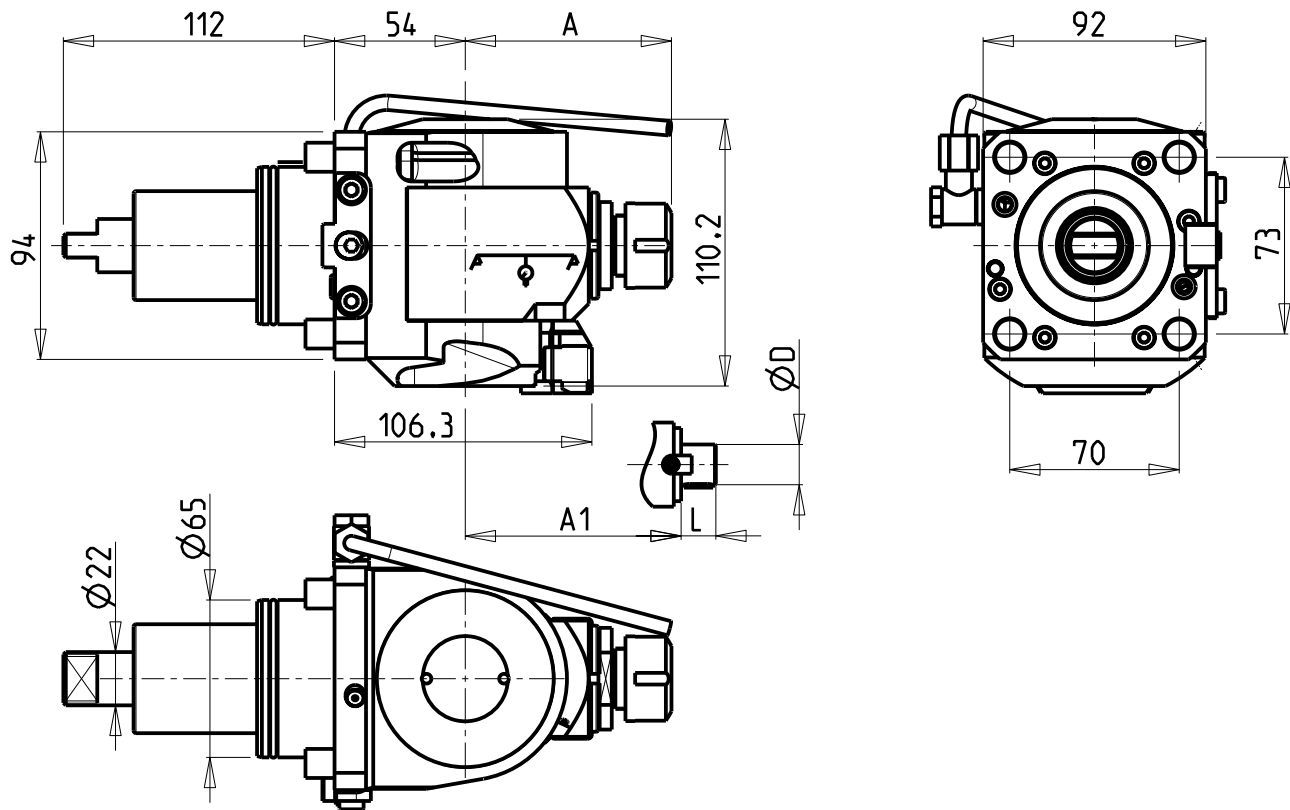

**ATTENZIONE - ATTENTION - ACHTUNG**

- VERIFICARE LE MISURE DI INGOMBRO PER POSSIBILE INTERFERENZA SU ALCUNI MODELLI DI MACCHINE
- Please check the overall sizes for possible interferences on some machine models
- Bitte überprüfen sie das ausmass um mögliche interferenzen auf einigen maschinen modellen zu vermeiden

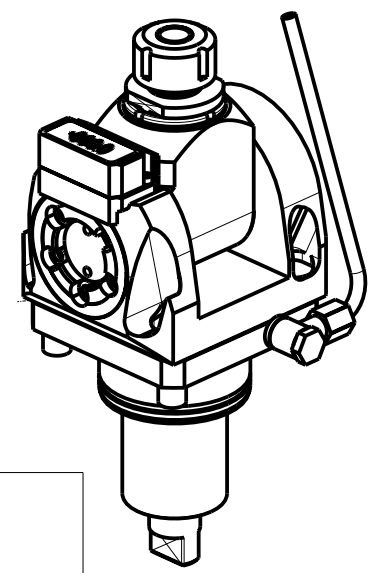

Cod. MT	Mandrino Spindle Spindel	I	RPM	Coppia Max Max Torque Max Drehmoment	Reversibile lato mandrino/contromandrino Reversible sub/main spindle side Umkehrbare Spindelseite/ Gegenspindelseite	Lubrificazione est. Ext. coolant Ausseenkuehlung	A	A1	D	L	CHIAVI INCLUSE Keys included Schlüssel inbegriffen		
											CH_VTCROCE_M08	CHUB36	CHESL10
DW 01850120	ER20	1:1	6000	40Nm	X	X	85.16	-	-	-	CHSTER20	CHUB36	CHESL10
DW 01850125	ER25	1:1	6000	40Nm	X	X	86.16	-	-	-	CHSTER25	CHUB36	CHESL10
DW 01850516	Ø16x17	1:1	6000	40Nm	X	X	-	65	16	17	CH_VTCROCE_M08	CHUB36	CHESL10
DW 01850522	Ø22x19	1:1	6000	40Nm	X	X	-	66	22	19	CH_VTCROCE_M10	CHUB36	CHESL10
DW 01850519	Ø3/4"x3/4"	1:1	6000	40Nm	X	X	-	65	3/4"	3/4"	CH_VTCROCE_M08	CHUB36	CHESL10

**SPINNER**

MOD: TC800 SMCY (BMT65)

MODULO MOTORIZZATO ORIENTABILE ±90° CON NONIO DIGITALE H=54mm

±90° adjustable angle driven tool with digital display H=54mm

Angetriebenes Werkzeug schwenkbar ±90° mit digital display H=54mm

Subject to change without notice.

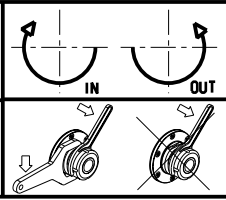

**M.T. srl**  
Via Casino Albini 480  
Tel. 0541/956034-957884  
Fax 0541/956341  
47842 S. GIOVANNI IN M. (RN)  
e-mail: mtma@mtmarchetti.com  
http://www.mtmarchetti.com

PRODUZIONE MODULI ROTANTI



PAGINA SPN333-2-01

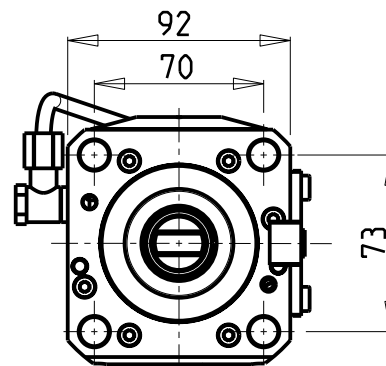
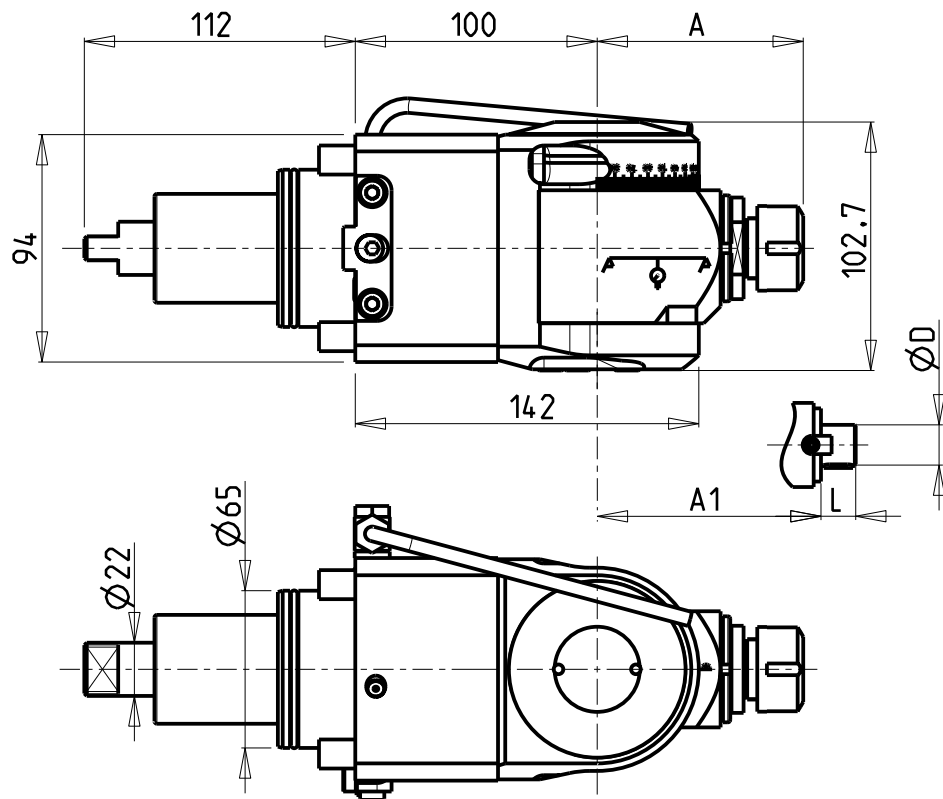

### ATTENZIONE - ATTENTION - ACHTUNG

- VERIFICARE LE MISURE DI INGOMBRO PER POSSIBILE INTERFERENZA SU ALCUNI MODELLI DI MACCHINE
- Please check the overall sizes for possible interferences on some machine models
- Bitte überprüfen sie das ausmass um mögliche interferenzen auf einigen maschinen modellen zu vermeiden

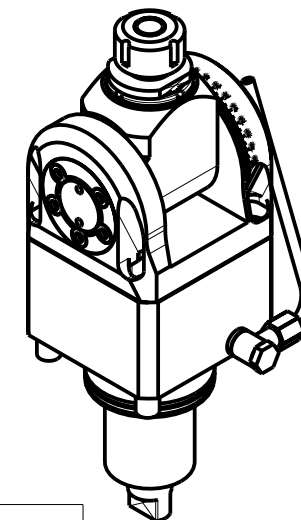

Cod. MT	Mandrino Spindle Spindel	I	RPM	Coppia Max Max Torque Max Drehmoment	Reversibile lato mandrino/contromandrino Reversible sub/main spindle side Umkehrbare Spindelseite/ Gegenspindelseite	Lubrificazione est. Ext. coolant Aussehenkuehlung	A	A1	D	L	CHIAVI INCLUSE Keys included Schlüssel inbegriffen		
											CH_VTCROCE_M08	CHUB36	CHESL10
DW 01930120	ER20	1:1	6000	40Nm	X	X	85.16	-	-	-	CHSTER20	CHUB36	CHESL10
DW 01930125	ER25	1:1	6000	40Nm	X	X	86.16	-	-	-	CHSTER25	CHUB36	CHESL10
DW 01930516	Ø16x17	1:1	6000	40Nm	X	X	-	65	16	17	CH_VTCROCE_M08	CHUB36	CHESL10
DW 01930522	Ø22x19	1:1	6000	40Nm	X	X	-	66	22	19	CH_VTCROCE_M10	CHUB36	CHESL10
DW 01930519	Ø3/4"x3/4"	1:1	6000	40Nm	X	X	-	65	3/4"	3/4"	CH_VTCROCE_M08	CHUB36	CHESL10

### SPINNER

MOD: TC800 SMCY (BMT65)

MODULO MOTORIZZATO ORIENTABILE ±90° H=100mm

±90° adjustable angle driven tool H=100mm

Angetriebenes Werkzeug schwenkbar ±90° H=100mm

Subject to change without notice.

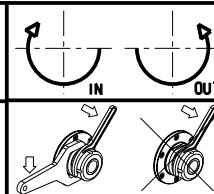

### M.T. srl

Via Casino Albini 480  
Tel. 0541/956034-957884  
Fax 0541/956341  
47842 S. GIOVANNI IN M. (RN)  
e-mail: mtma@mtmarchetti.com  
http://www.mtmarchetti.com

PRODUZIONE MODULI ROTANTI



PAGINA SPN333-2-10

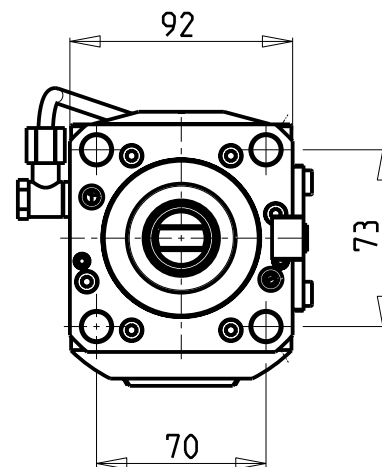
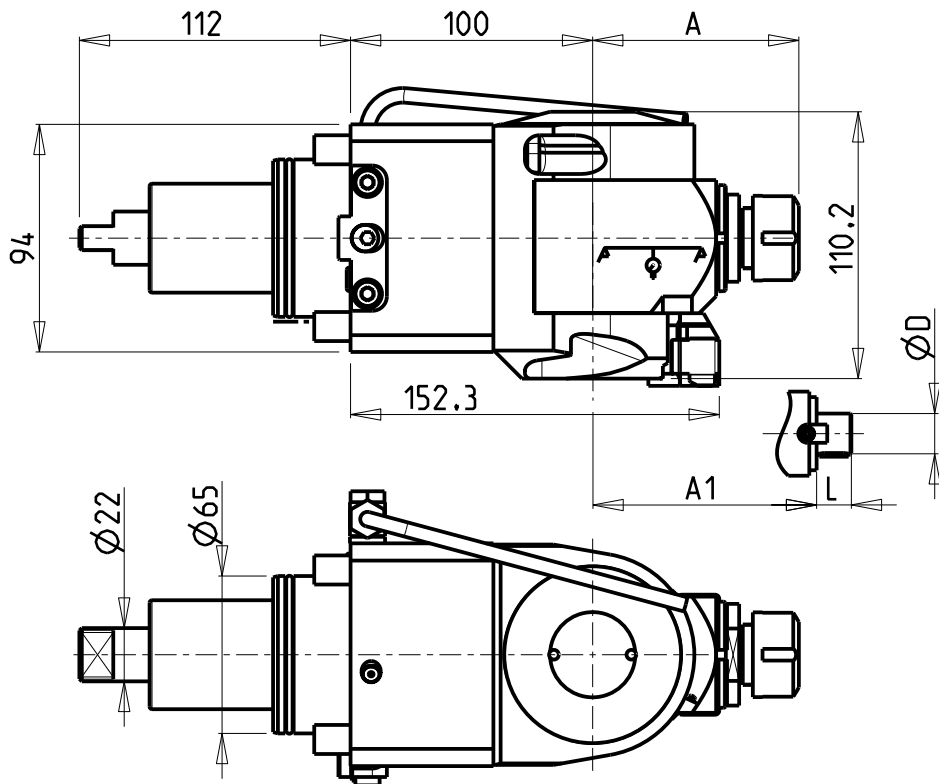

**ATTENZIONE - ATTENTION - ACHTUNG**

- VERIFICARE LE MISURE DI INGOMBRO PER POSSIBILE INTERFERENZA SU ALCUNI MODELLI DI MACCHINE
- Please check the overall sizes for possible interferences on some machine models
- Bitte überprüfen sie das ausmass um mögliche interferenzen auf einigen maschinen modellen zu vermeiden

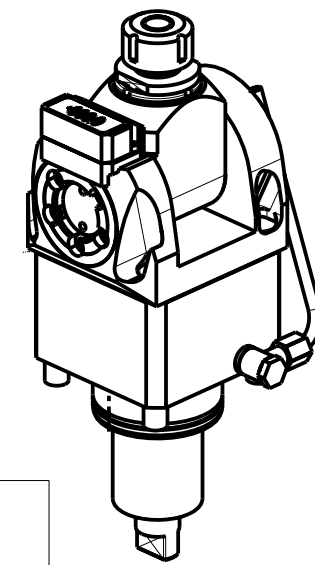

Cod. MT	Mandrino Spindle Spindel	I	RPM	Coppia Max Max Torque Max Drehmoment	Reversibile lato mandrino/contromandrino Reversible sub/main spindle side Umkehrbare Spindel-seite/ Gegenspindel-seite	Lubrificazione est. Ext. coolant Aussehenkuehlung	A	A1	D	L	CHIAVI INCLUSE Keys included Schluessel inbegriffen		
											CH_VTCROCE_M08	CHUB36	CHESL10
DW 01860120	ER20	1:1	6000	40Nm	X	X	85.16	-	-	-	CHSTER20	CHUB36	CHESL10
DW 01860125	ER25	1:1	6000	40Nm	X	X	86.16	-	-	-	CHSTER25	CHUB36	CHESL10
DW 01860516	Ø16x17	1:1	6000	40Nm	X	X	-	65	16	17	CH_VTCROCE_M08	CHUB36	CHESL10
DW 01860522	Ø22x19	1:1	6000	40Nm	X	X	-	66	22	19	CH_VTCROCE_M10	CHUB36	CHESL10
DW 01860519	Ø3/4"x3/4"	1:1	6000	40Nm	X	X	-	65	3/4"	3/4"	CH_VTCROCE_M08	CHUB36	CHESL10

**SPINNER**  
MOD: TC800 SMCY (BMT65)

MODULO MOTORIZZATO ORIENTABILE ±90° CON NONIO DIGITALE H=100mm  
±90° adjustable angle driven tool with digital display H=100mm  
Angetriebenes Werkzeug schwenkbar ±90° mit digital display H=100mm

Subject to change without notice.

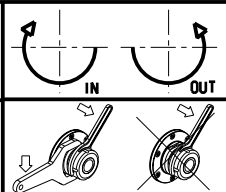

**M.T. srl**  
Via Casino Albini 480  
Tel. 0541/956034-957884  
Fax 0541/956341  
47842 S. GIOVANNI IN M. (RN)  
e-mail: mtma@mtmarchetti.com  
http://www.mtmarchetti.com

PRODUZIONE MODULI ROTANTI



PAGINA SPN333-2-11

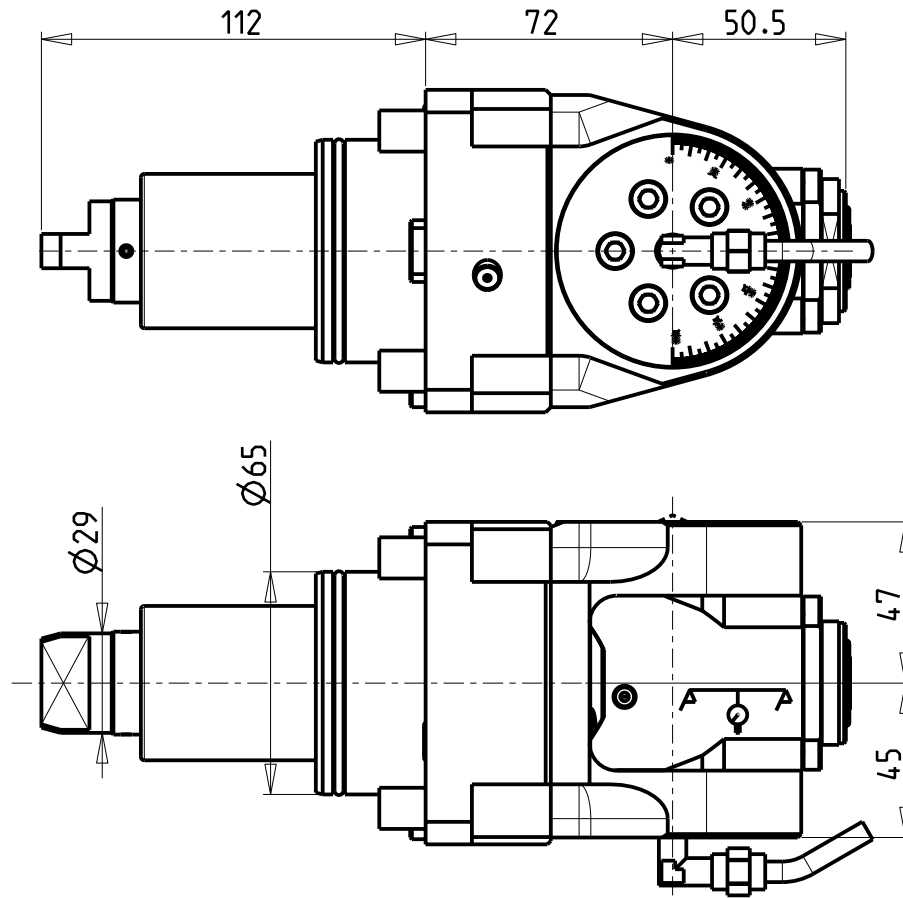
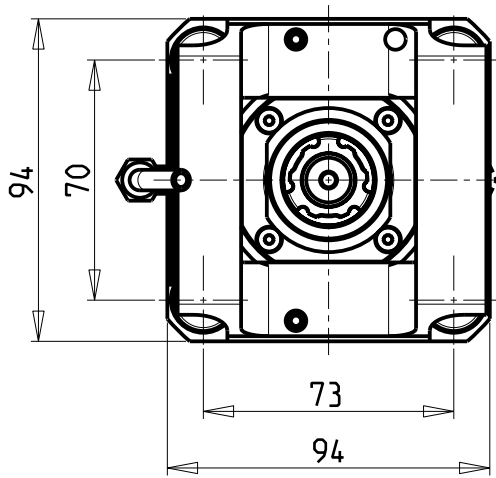

**ATTENZIONE - ATTENTION - ACHTUNG**

- Per lo smontaggio degli utensili utilizzare sempre la chiave di contrasto come indicato nel manuale d'uso.
- For disassembly of the tools use always the contrast key as mentioned in the user instructions.
- Fuer das Abmontieren der Werkzeuge immer den Gegenschlüssel benutzen wie in der Bedienungsanleitung erwaeht.

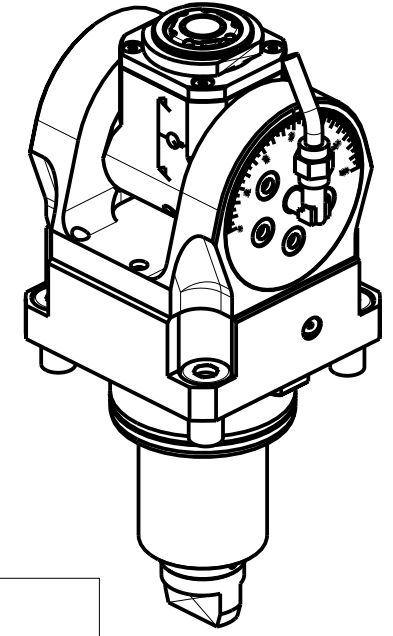

Cod. MT	Mandrino Spindle Spindel	I	RPM	Coppia Max Max Torque Max Drehmoment	Reversibile lato mandrino/contromandrino	Lubrificazione int. Coolant through Innenkuehlung	Lubrificazione est. Ext. coolant Aussenkuehlung	CHIAVI INCLUSE Keys included Schluessel inbegriffen			
					Reversible sub/main spindle side Umkehrbare Spindel-seite/ Gegenspindel-seite						
DW01940120	ERA20	1:1	6000	30Nm	X	-	X	CHUB36	CHUB22	CHTAER20ZC	CHESL08
DW01940220	ERA20	1:1	6000	30Nm	X	P=70bar	X	CHUB36	CHUB22	CHTAER20ZC	CHESL08

**SPINNER**  
MOD: TC800 SMCY (BMT65)

MODULO MOTORIZZATO ORIENTABILE ±90° H=72mm  
±90° adjustable angle driven tool H=72mm  
Angetriebenes Werkzeug schwenkbar ±90° H=72mm

Subject to change without notice.

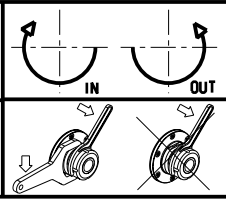

**M.T. srl**  
Via Casino Albini 480  
Tel. 0541/956034-957884  
Fax 0541/956341  
47842 S. GIOVANNI IN M. (RN)  
e-mail: mtma@mtmarchetti.com  
http://www.mtmarchetti.com

PRODUZIONE MODULI ROTANTI  
**MT**  
PAGINA SPN335-2-00

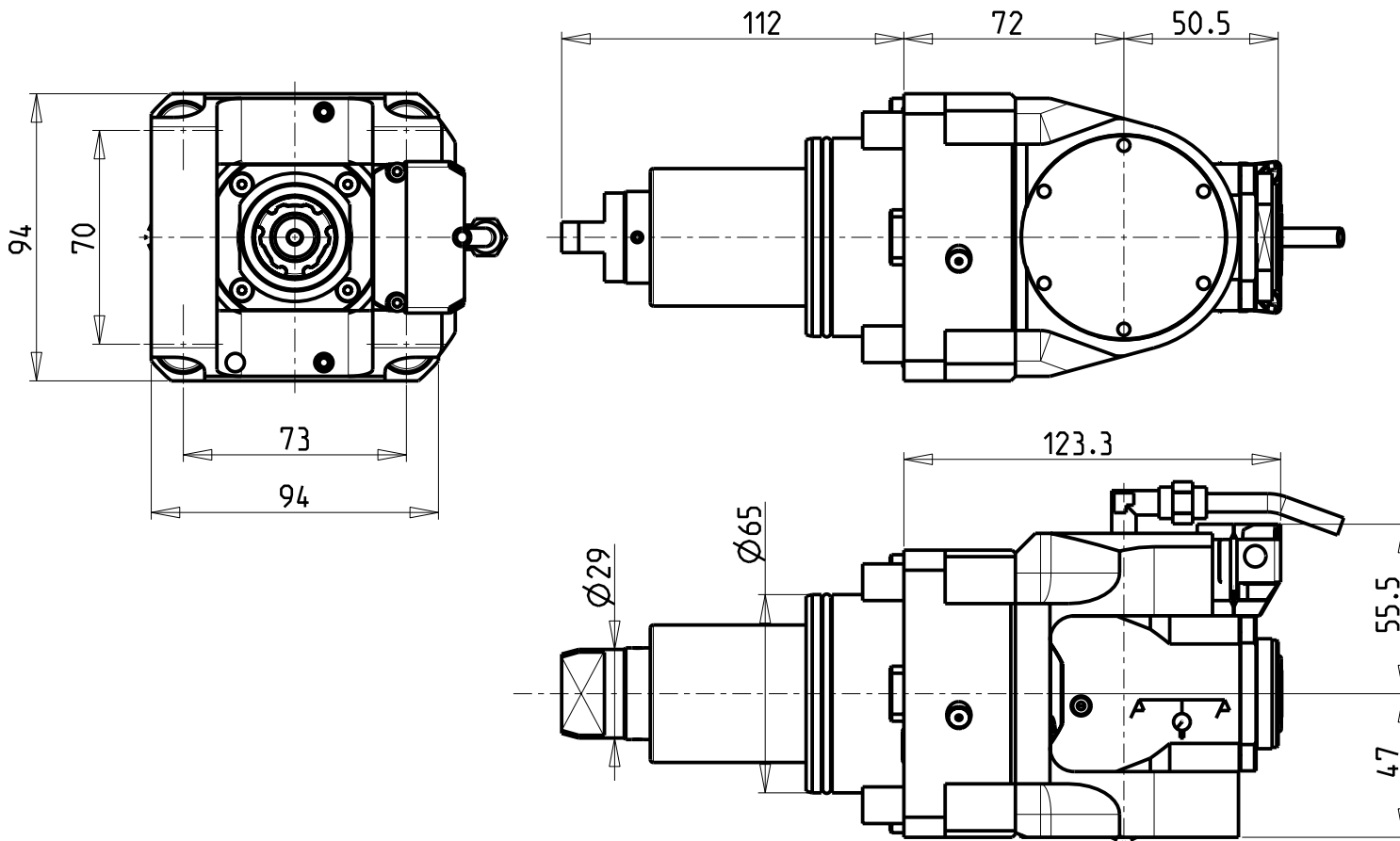

### ATTENZIONE - ATTENTION - ACHTUNG

- Per lo smontaggio degli utensili utilizzare sempre la chiave di contrasto come indicato nel manuale d'uso.
- For disassembly of the tools use always the contrast key as mentioned in the user instructions.
- Fuer das Abmontieren der Werkzeuge immer den Gegenschlüssel benutzen wie in der Bedienungsanleitung erwaeht.

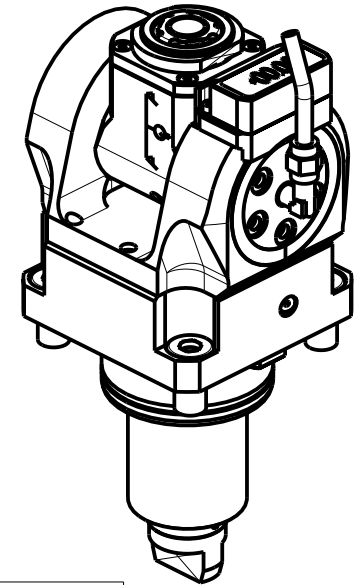

Cod. MT	Mandrino Spindle Spindel	I	RPM	Coppia Max Max Torque Max Drehmoment	Reversibile lato mandrino/contromandrino Reversible sub/main spindle side Umkehrbare Spindel-seite/ Gegenspindel-seite	Lubrificazione int. Coolant through Innenkuehlung	Lubrificazione est. Ext. coolant Ausseinkuehlung	CHIAVI INCLUSE Keys included Schluessel inbegriffen			
								CHUB36	CHUB22	CHTAER20ZC	CHESL08
DW01945120	ERA20	1:1	6000	30Nm	X	-	X	CHUB36	CHUB22	CHTAER20ZC	CHESL08
DW01945220	ERA20	1:1	6000	30Nm	X	P=70bar	X	CHUB36	CHUB22	CHTAER20ZC	CHESL08

### SPINNER

MOD: TC800 SMCY (BMT65)

MODULO MOTORIZZATO ORIENTABILE  $\pm 90^\circ$  CON NONIO DIGITALE H=72mm  
 $\pm 90^\circ$  adjustable angle driven tool with digital display H=72mm  
 Angetriebenes Werkzeug schwenkbar  $\pm 90^\circ$  mit digital display H=72mm

Subject to change without notice.

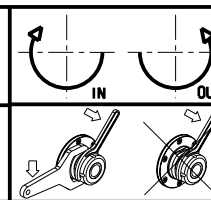

### M.T. srl

Via Casino Albini 480  
 Tel. 0541/956034-957884  
 Fax 0541/956341  
 47842 S. GIOVANNI IN M. (RN)  
 e-mail: mtma@mtmarchetti.com  
 http://www.mtmarchetti.com

PRODUZIONE MODULI ROTANTI



PAGINA SPN335-2-01

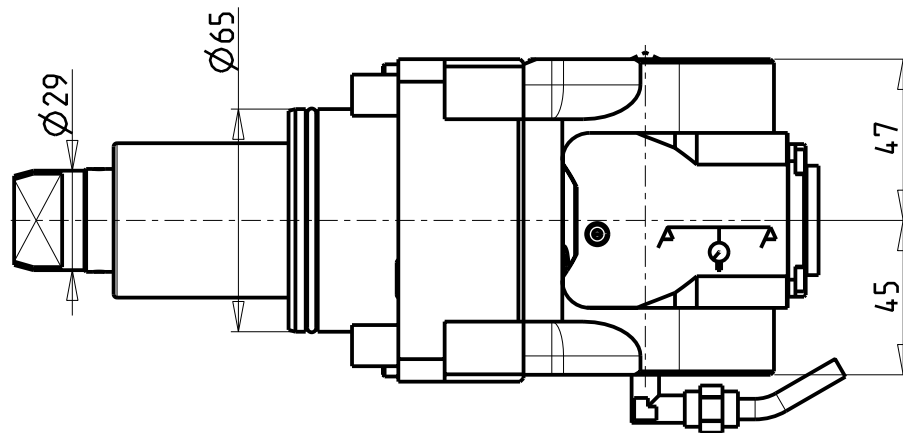
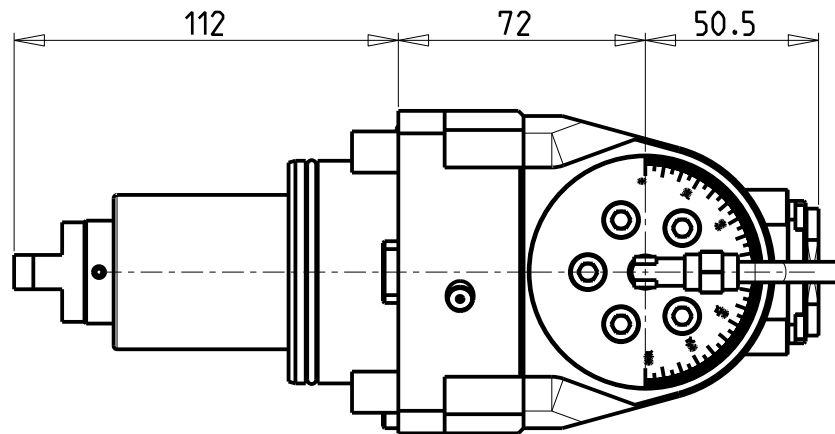
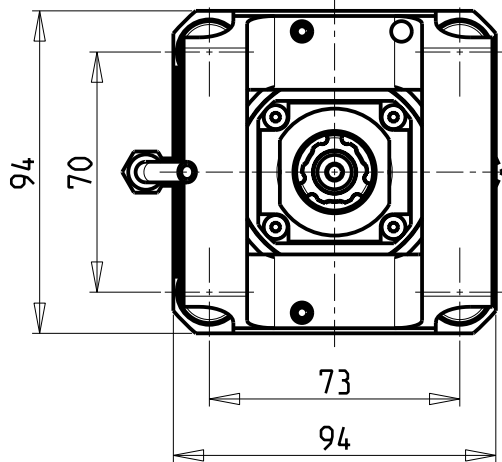

**ATTENZIONE - ATTENTION - ACHTUNG**

- Per lo smontaggio degli utensili utilizzare sempre la chiave di contrasto come indicato nel manuale d'uso.
- For disassembly of the tools use always the contrast key as mentioned in the user instructions.
- Fuer das Abmontieren der Werkzeuge immer den Gegenschlüssel benutzen wie in der Bedienungsanleitung erwaeht.

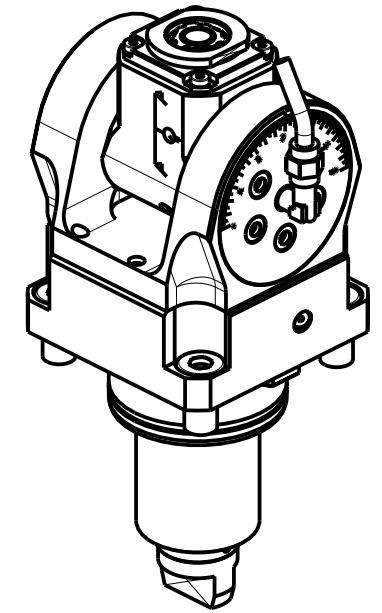

Cod. MT	Mandrino Spindle Spindel	i	RPM	Coppia Max Max Torque Max Drehmoment	Reversibile lato mandrino/contromandrino Reversible sub/main spindle side Umkehrbare Spindel-seite/ Gegenspindel-seite	Lubrificazione int. Coolant through Innenkuehlung	Lubrificazione est. Ext. coolant Aussenkuehlung	CHIAVI INCLUSE Keys included Schluessel inbegriffen			
					X	-	X	CHUB19_SP3	CHUB32	CHTAER16ZC	CHESL08
DW01940316	ERA16	1:2	12000	8Nm	X	-	X	CHUB19_SP3	CHUB32	CHTAER16ZC	CHESL08
DW01940416	ERA16	1:2	12000	8Nm	X	P=70bar	X	CHUB19_SP3	CHUB32	CHTAER16ZC	CHESL08

**SPINNER**  
 MOD: TC800 SMCY (BMT65)

MODULO MOTORIZZATO ORIENTABILE ±90° MOLTIPLICATO i=1:2 H=72mm  
 ±90° adjustable angle driven tool geared-up i=1:2 H=72mm  
 Angetriebenes Werkzeug schwenkbar ±90° uebersetzt i=1:2 H=72mm

Subject to change without notice.

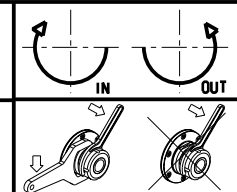

**M.T. srl**  
 Via Casino Albini 480  
 Tel. 0541/956034-957884  
 Fax 0541/956341  
 47842 S. GIOVANNI IN M. (RN)  
 e-mail: mtma@mtmarchetti.com  
 http://www.mtmarchetti.com

PRODUZIONE MODULI ROTANTI  
  
 PAGINA SPN336-2-00

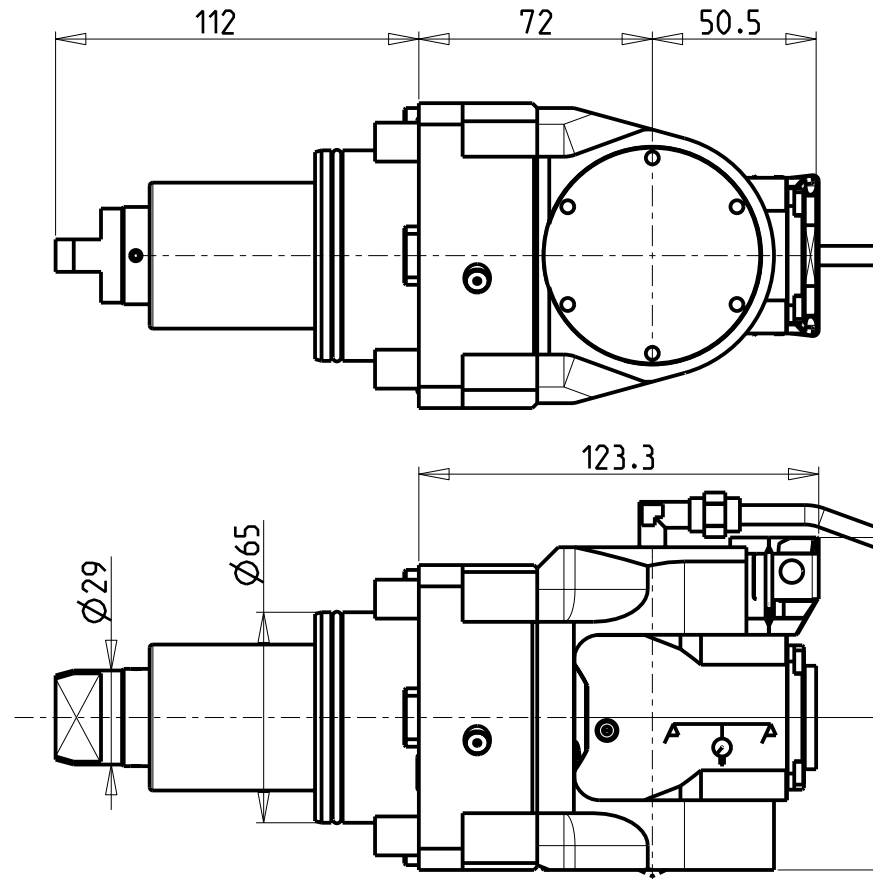
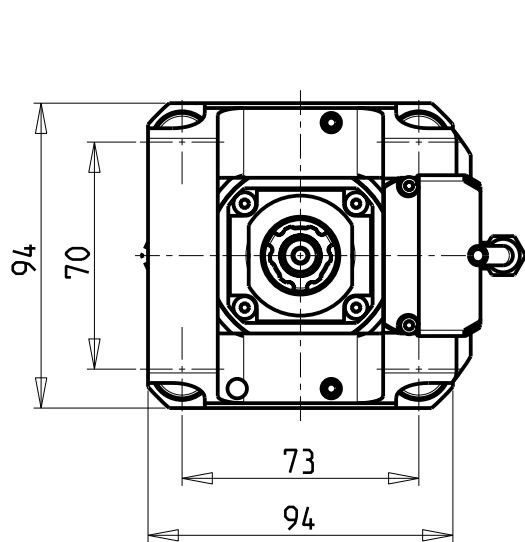

### ATTENZIONE - ATTENTION - ACHTUNG

- Per lo smontaggio degli utensili utilizzare sempre la chiave di contrasto come indicato nel manuale d'uso.
- For disassembly of the tools use always the contrast key as mentioned in the user instructions.
- Fuer das Abmontieren der Werkzeuge immer den Gegenschlüssel benutzen wie in der Bedienungsanleitung erwaeht.

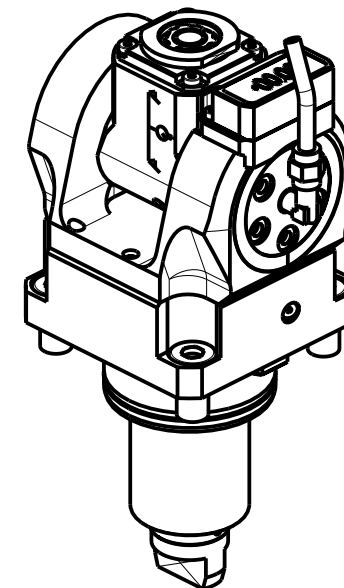

Cod. MT	Mandrino Spindle Spindel	I	RPM	Coppia Max Max Torque Max Drehmoment	Reversibile lato mandrino/contromandrino Reversible sub/main spindle side Umkehrbare Spindel-seite/ Gegenspindel-seite	Lubrificazione int. Coolant through Innenkuehlung	Lubrificazione est. Ext. coolant Ausseinkuehlung	CHIAVI INCLUDE Keys included Schluessel inbegriffen			
								CHUB19_SP3	CHUB32	CHTAER16ZC	CHESL08
DW01945316	ERA16	1:2	12000	8Nm	X	-	X	CHUB19_SP3	CHUB32	CHTAER16ZC	CHESL08
DW01945416	ERA16	1:2	12000	8Nm	X	P=70bar	X	CHUB19_SP3	CHUB32	CHTAER16ZC	CHESL08

### SPINNER

MOD: TC800 SMCY (BMT65)

MODULO MOTORIZZATO ORIENTABILE  $\pm 90^\circ$  MOLTIPLICATO I=1:2 CON NONIO DIGITALE H=72mm  
 $\pm 90^\circ$  adjustable angle driven tool geared-up I=1:2 with digital display H=72mm  
 Angetriebenes Werkzeug schwenkbar  $\pm 90^\circ$  uebersetzt I=1:2 mit digital display H=72mm

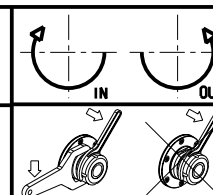

### M.T. srl

Via Casino Albini 480  
 Tel. 0541/956034-957884  
 Fax 0541/956341  
 47842 S. GIOVANNI IN M. (RN)  
 e-mail: mtma@mtmarchetti.com  
 http://www.mtmarchetti.com

PRODUZIONE MODULI ROTANTI



PAGINA SPN336-2-01

Subject to change without notice.

10/2018

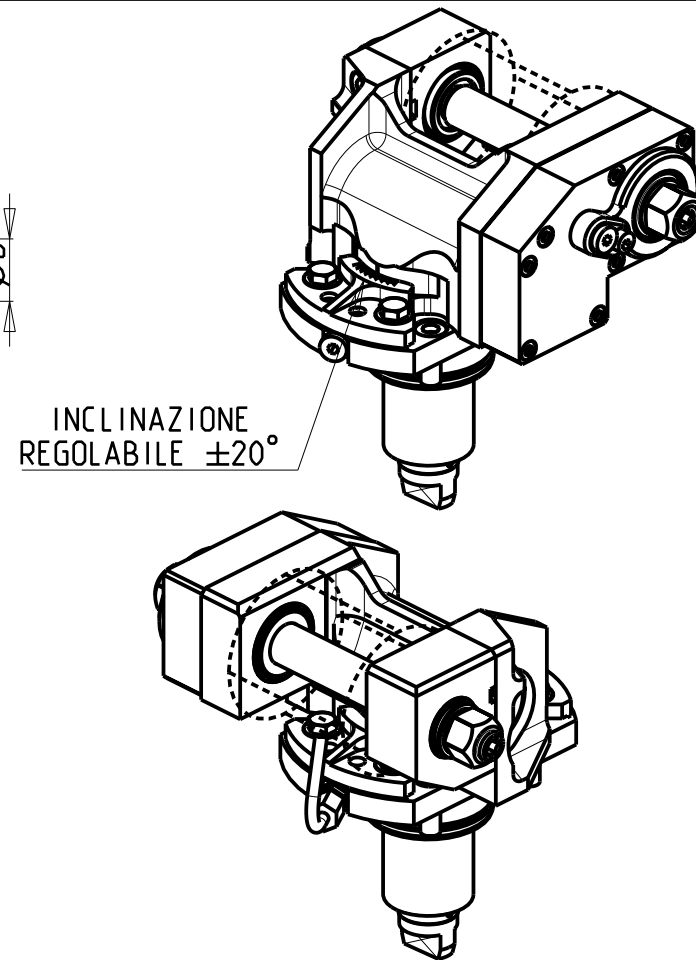
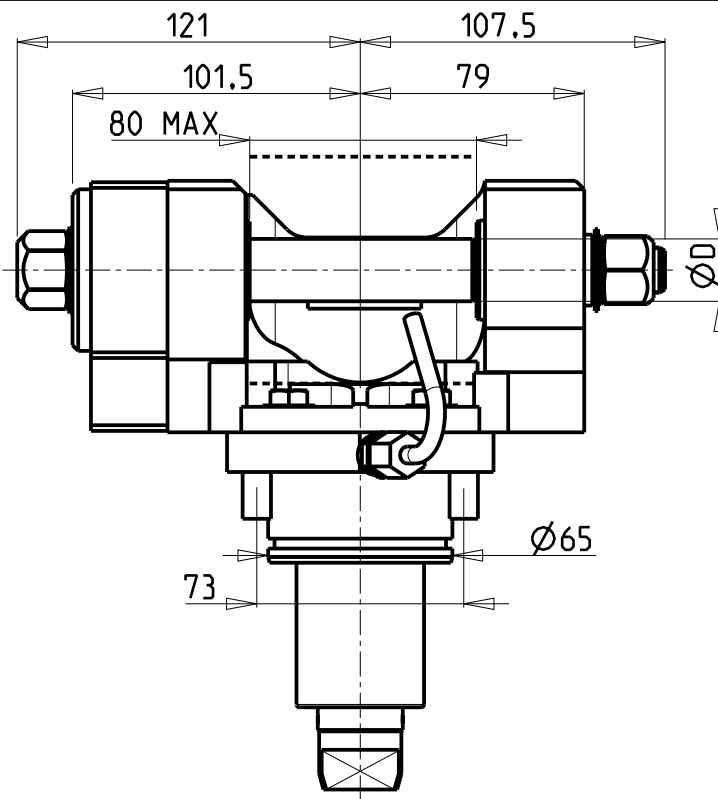
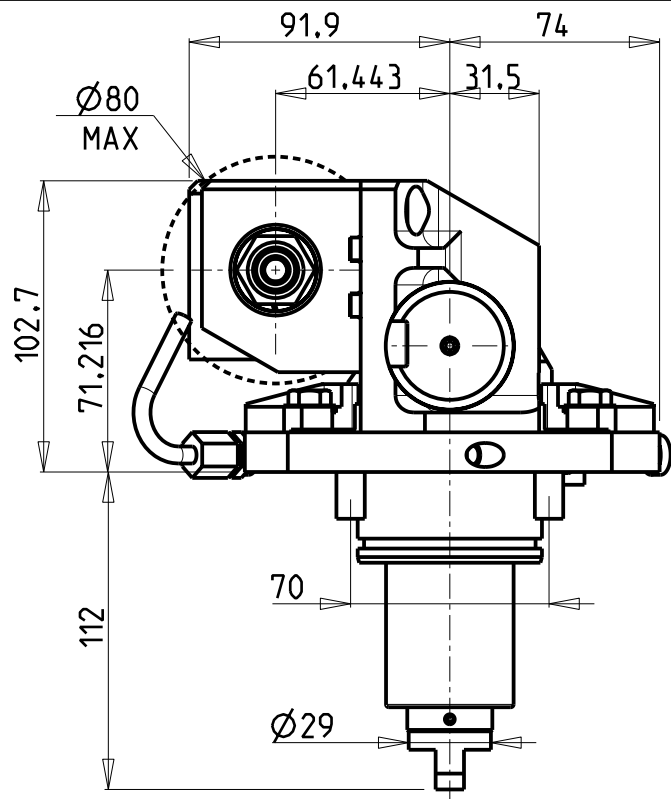

INCLINAZIONE  
REGOLABILE  $\pm 20^\circ$

**DOTAZIONI - SUPPLIED WITH - AUSSTATTUNG**

- N°1 ALBERO + DISTANZIALI
- N°1 SHAFT + SPACER
- N°1 DORN + ABSTANDSSTUECK

PER ALBERI E DISTANZIALI VEDI PAG. TBL250-1-00  
FOR SHAFT END SPACER SEE PAGE TBL250-1-00  
FUER DORN UND ABSTANDSSTUECK SEITE TBL250-1-00

Cod. MT	I	RPM	Coppia Max Max Torque Max Drehmoment	Reversibile lato mandrino/contromandrino Reversible sub/main spindle side Umkehrbare Spindel-seite/ Gegenspindel-seite	Lubrificazione est. Ext. coolant Aussenkuehlung	D (mm)	D (Inch)	CHIAVI INCLUSE Keys included Schlüssel inbegriffen		
				X	X	16-22-27-32	3/4"-1"-1 1/4"	CHUB24	CHUB13	CHESL08
0321100	1:1	6000	60Nm	X	X	16-22-27-32	3/4"-1"-1 1/4"	CHUB24	CHUB13	CHESL08
0322100	2:1	3000	80Nm	X	X	16-22-27-32	3/4"-1"-1 1/4"	CHUB24	CHUB13	CHESL08

**SPINNER**

MOD: TC800 SMCY (BMT65)

MODULO MOTORIZZATO PORTACREATORE

Driven gear hobber

Angetriebenes Zahnradwaeltzraes-Werkzeug

Subject to change without notice.

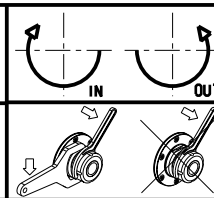

**M.T. srl**

Via Casino Albini 480  
Tel. 0541/956034-957884  
Fax 0541/956341  
47842 S. GIOVANNI IN M. (RN)  
e-mail: mtma@tmarchetti.com  
http://www.tmmarchetti.com

PRODUZIONE MODULI ROTANTI



PAGINA SPN340-2-00



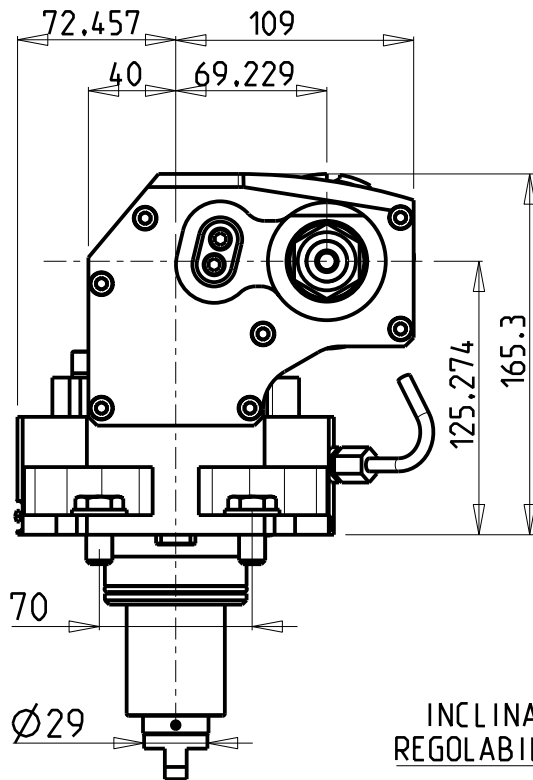
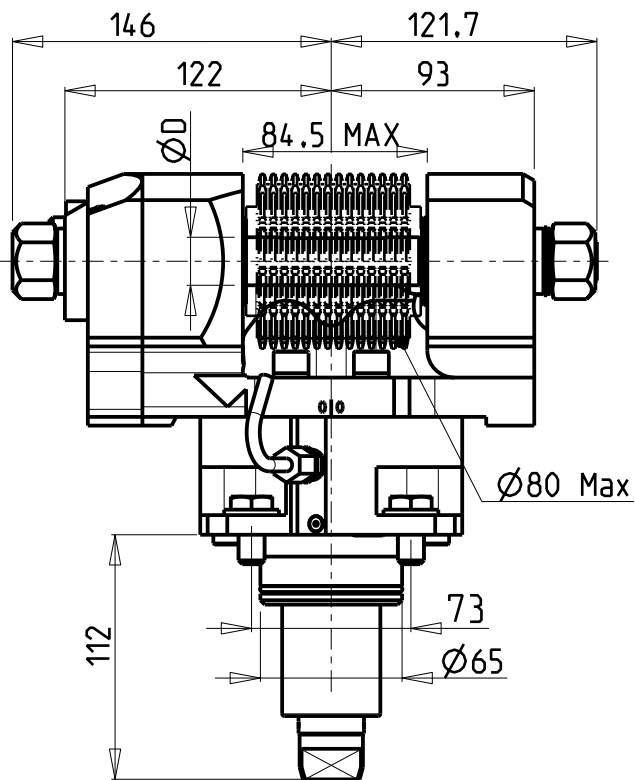

INCLINAZIONE  
REGOLABILE  $\pm 30^\circ$

**ATTENZIONE - ATTENTION - ACHTUNG**

- VERIFICARE LE MISURE DI INGOMBRO PER POSSIBILE INTERFERENZA SU ALCUNI MODELLI DI MACCHINE
- Please check the overall sizes for possible interferences on some machine models
- Bitte überprüfen sie das ausmass um mögliche interferenzen auf einigen maschinen modellen zu vermeiden

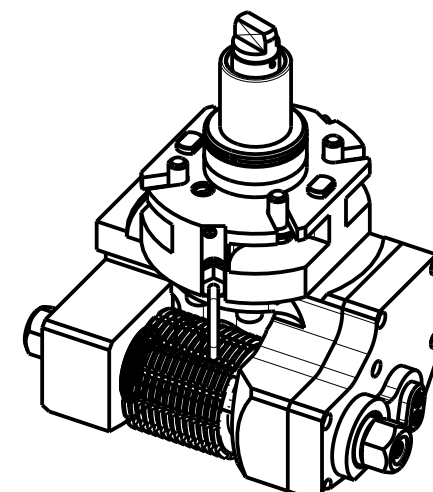
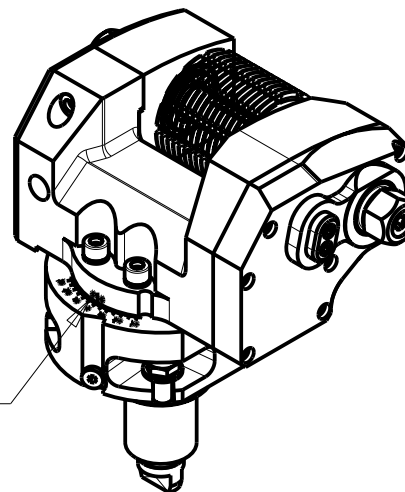

**DOTAZIONI - SUPPLIED WITH - AUSSTATTUNG**

- mm / inch
- N°1 ALBERO + DISTANZIALI
  - N°1 SHAFT + SPACER
  - N°1 DORN + ABSTANDSSTUECK

PER ALBERI E DISTANZIALI VEDI PAG. TBL250-1-00  
FOR SHAFT END SPACER SEE PAGE TBL250-1-00  
FUER DORN UND ABSTANDSSTUECK SEITE TBL250-1-00

Cod. MT	I	RPM	Coppia Max Max Torque Max Drehmoment	Lubrificazione est. Ext. coolant Aussenkuehlung	D (mm)	D (Inch)	CHIAVI INCLUSE Keys included Schluessel inbegriffen			
							CHUB30	CHUB19	CHESL08	CHUB24 (Ø16 / Ø3/4")
DW00031100	1:1	6000	90Nm	X	16-22-27-32	3/4"-1"-1 1/4"	CHUB30	CHUB19	CHESL08	CHUB24 (Ø16 / Ø3/4")
DW00032100	2:1	3000	110Nm	X	16-22-27-32	3/4"-1"-1 1/4"	CHUB30	CHUB19	CHESL08	CHUB24 (Ø16 / Ø3/4")

**SPINNER**

MOD: TC800 SMCY (BMT65)

MODULO MOTORIZZATO PORTACREATORE MAGGIORATO

Reinforced driven gear hobber

Angetriebenes Zahnradwaelzfraes-Werkzeug vergroessert

Subject to change without notice.

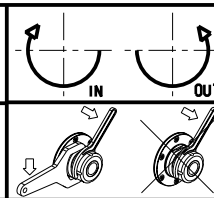

**M.T. srl**

Via Casino Albini 480  
Tel. 0541/956034-957884  
Fax 0541/956341  
47842 S. GIOVANNI IN M. (RN)  
e-mail: mtma@mtmarchetti.com  
http://www.mtmarchetti.com

PRODUZIONE MODULI ROTANTI



PAGINA SPN340-2-60

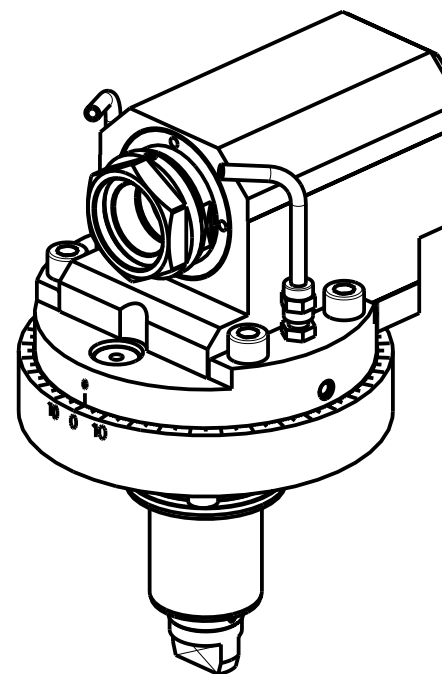
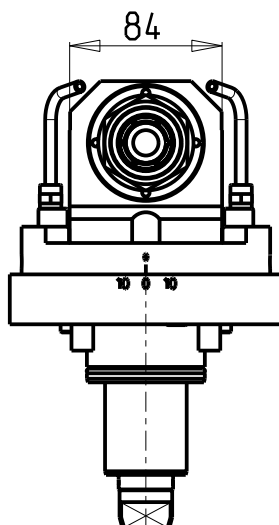
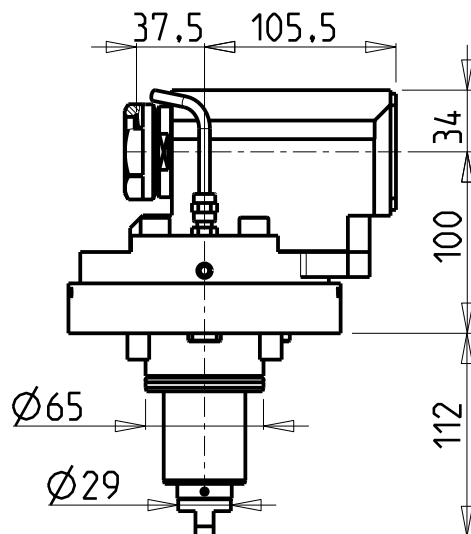
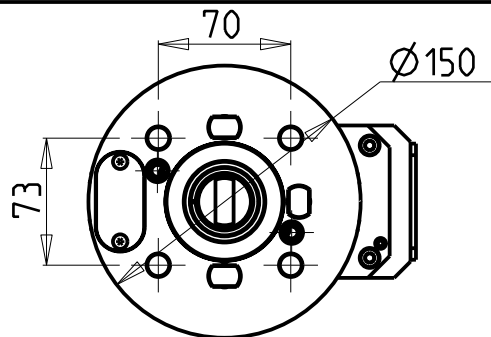

**ATTENZIONE - ATTENTION - ACHTUNG**

- VERIFICARE LE MISURE DI INGOMBRO PER POSSIBILE INTERFERENZA SU ALCUNI MODELLI DI MACCHINE
- Please check the overall sizes for possible interferences on some machine models
- Bitte überprüfen sie das ausmass um mögliche interferenzen auf einigen maschinen modellen zu vermeiden

PER PORTAUTENSILI MODULARI MTSK-40 VEDI PAG. TBL300-1-40  
 FOR MTSK-40 QUICK CHANGE TOOLHOLDERS CLAMPINGS SEE PAGE TBL300-1-40  
 FUER MTSK-40 MODULARE WERKZEUGAUFNAHMEN SIEHE SEITE TBL300-1-40

Cod. MT	Mandrino Spindle Spindel	I	RPM	Coppia Max Max Torque Max Drehmoment	Reversibile lato mandrino/contromandrino Reversible sub/main spindle side Umkehrbare Spindel-seite/Gegenspindel-seite	Lubr.esterna Ext. coolant Aussenkuehlung	CHIAVI INCLUSE Keys included Schluessel einbegriffen
DW01770100	MTSK-40	1:1	6000	50Nm	X	X	n°2 CHUB46

**SPINNER**  
 MOD: TC800 SMCY (BMT65)

MODULO MOTORIZZATO ASSIALE MTSK PER POWER SKIVING H=100mm  
 Axial MTSK driven tool for Power Skiving H=100mm  
 Axial MTSK angetriebenes Werkzeug fuer Power Skiving H=100mm

Subject to change without notice.

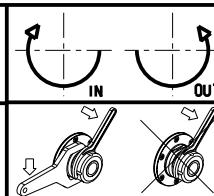

**M.T. srl**  
 Via Casino Albini 480  
 Tel. 0541/956034-957884  
 Fax 0541/956341  
 47842 S. GIOVANNI IN M. (RN)  
 e-mail: mtma@mtmarchetti.com  
 http://www.mtmarchetti.com

PRODUZIONE MODULI ROTANTI



PAGINA SPN350-2-00-K

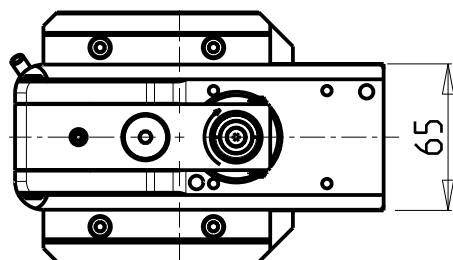
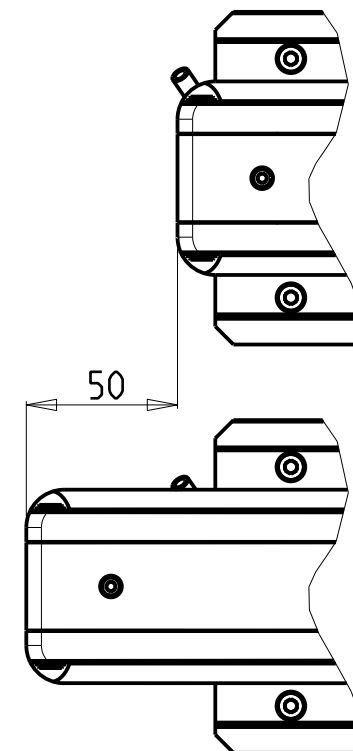
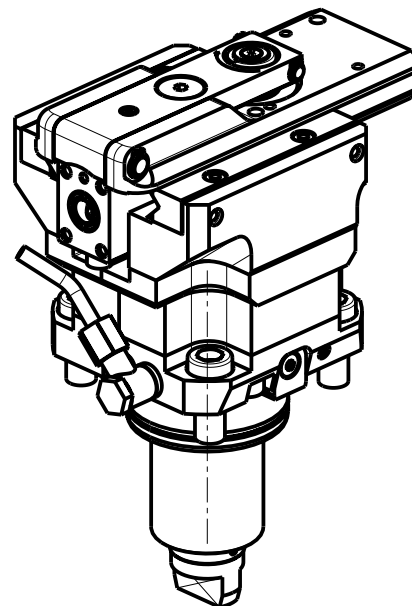
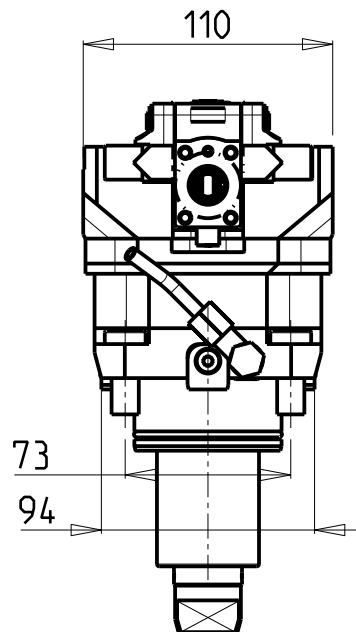
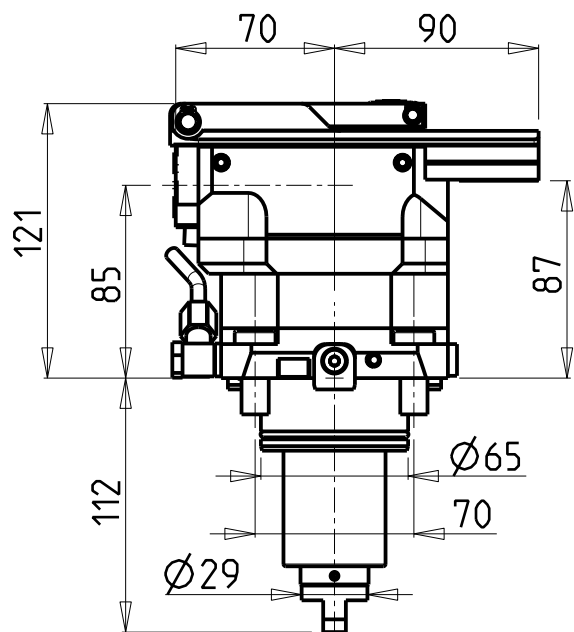

PER UTENSILI STOZZATORI VEDI PAG. TBL400-1-00  
 FOR DRIVEN SLOTTING TOOL CUTTING-TOOLS SEE PAGE TBL400-1-00  
 FÜR NUTENSTOSS-WERKZEUG SCHNEIDWERKZEUGE SIEHE SEITE TBL400-1-00

Cod. MT	I	RPM MAX	Reversibile lato mandrino/contromandrino Reversible sub/main spindle side Umkehrbare Spindel-seite/ Gegenspindel-seite	Lubr. esterna Ext. coolant Aussenkuehlung
DW 01530100	4:1	2000	X	X

**SPINNER**

MOD: TC800 SMCY (BMT65)

MODULO MOTORIZZATO STOZZATORE CORSA 50mm H=85mm

Slotting driven tool 50mm stroke H=85mm

Keilnutenstossmaschine 50mm Hub H=85mm

Subject to change without notice.

**M.T. srl**

Via Casino Albini 480  
 Tel. 0541/956034-957884  
 Fax 0541/956341  
 47842 S. GIOVANNI IN M. (RN)  
 e-mail: mtma@mtmarchetti.com  
 http://www.mtmarchetti.com

PRODUZIONE MODULI ROTANTI



PAGINA SPN360-2-00

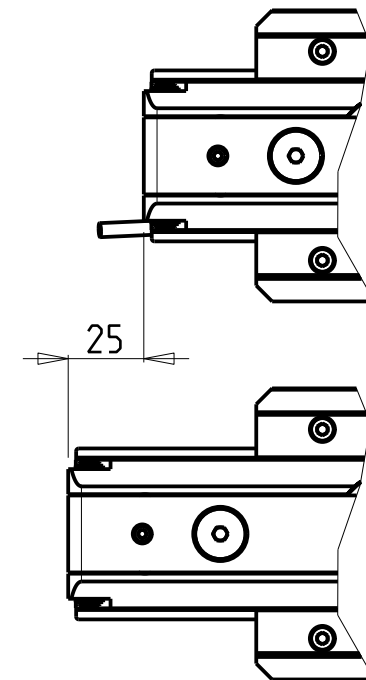
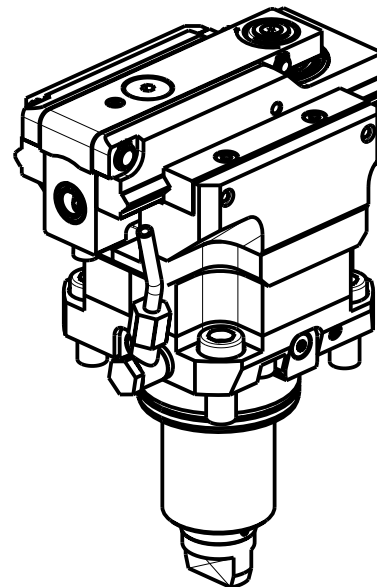
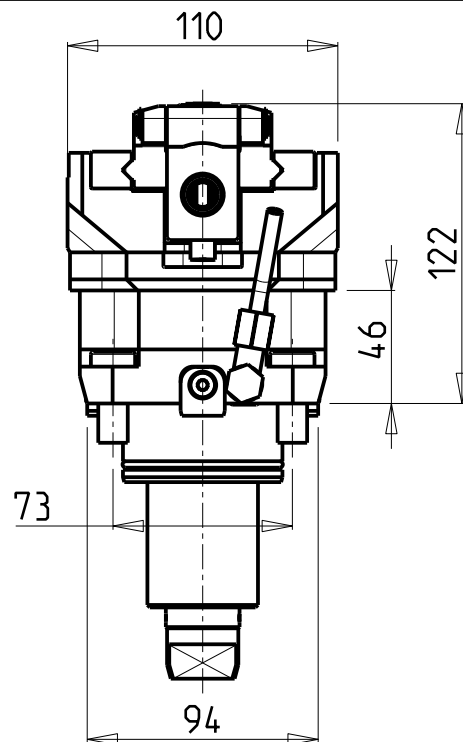
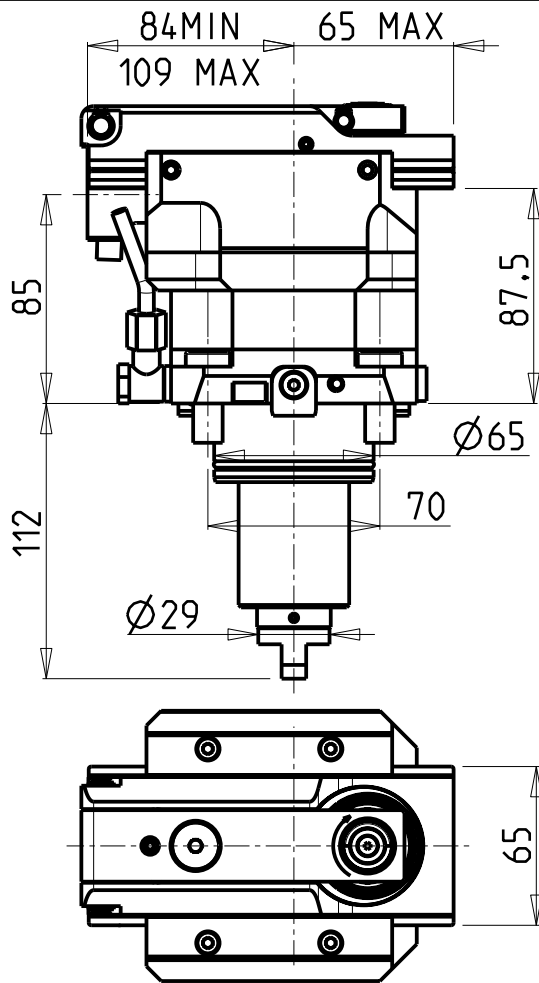

PER UTENSILI STOZZATORI VEDI PAG. TBL400-1-00  
 FOR DRIVEN SLOTTING TOOL CUTTING-TOOLS SEE PAGE TBL400-1-00  
 FÜR NUTENSTOSS-WERKZEUG SCHNEIDWERKZEUGE SIEHE SEITE TBL400-1-00

Cod. MT	I	RPM MAX	Reversibile lato mandrino/contromandrino Reversible sub/main spindle side Umkehrbare Spindel-seite/ Gegenspindel-seite	Lubr. esterna Ext. coolant Aussenkuehlung
DW01530200	4:1	2400	X	X

**SPINNER**

MOD: TC800 SMCY (BMT65)

MODULO MOTORIZZATO STOZZATORE CORSA 25mm H=85mm

Slotting driven tool 25mm stroke H=85mm

Keilnutenstossmaschine 25mm Hub H=85mm

Subject to change without notice.

**M.T. srl**

Via Casino Albini 480  
 Tel. 0541/956034-957884  
 Fax 0541/956341  
 47842 S. GIOVANNI IN M. (RN)  
 e-mail: mtma@mtmarchetti.com  
 http://www.mtmarchetti.com

PRODUZIONE MODULI ROTANTI



PAGINA SPN360-2-01

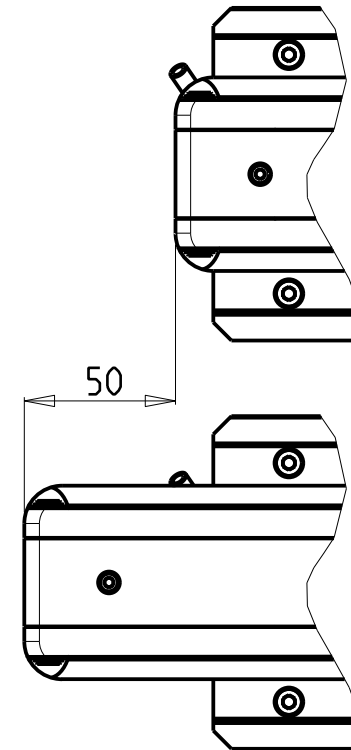
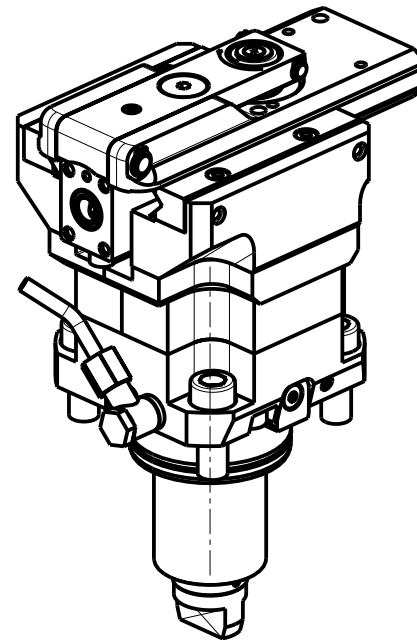
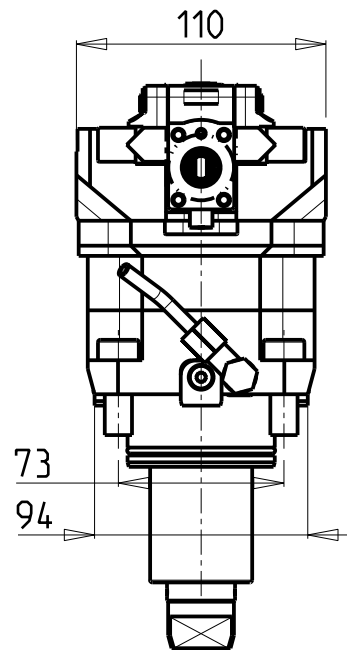
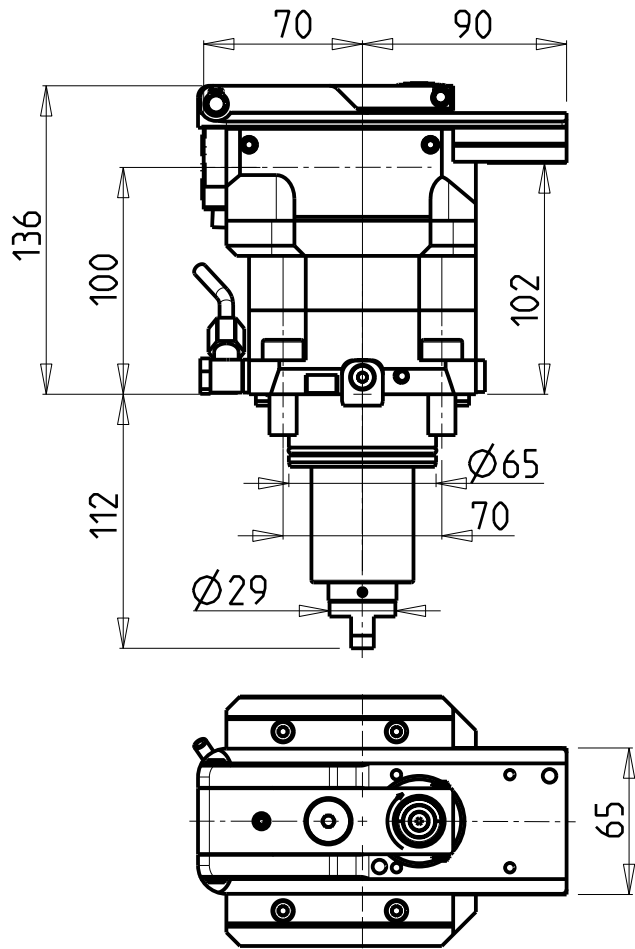

PER UTENSILI STOZZATORI VEDI PAG. TBL400-1-00  
 FOR DRIVEN SLOTTING TOOL CUTTING-TOOLS SEE PAGE TBL400-1-00  
 FÜR NUTENSTOSS-WERKZEUG SCHNEIDWERKZEUGE SIEHE SEITE TBL400-1-00

Cod. MT	I	RPM MAX	Reversibile lato mandrino/contromandrino Reversible sub/main spindle side Umkehrbare Spindel-seite/ Gegenspindel-seite	Lubr. esterna Ext. coolant Aussenkuehlung
DW 01520100	4:1	2000	X	X

**SPINNER**

MOD: TC800 SMCY (BMT65)

MODULO MOTORIZZATO STOZZATORE CORSA 50mm H=100mm

Slotting driven tool 50mm stroke H=100mm

Keilnutenstossmaschine 50mm Hub H=100mm

Subject to change without notice.

**M.T. srl**

Via Casino Albini 480  
 Tel. 0541/956034-957884  
 Fax 0541/956341  
 47842 S. GIOVANNI IN M. (RN)  
 e-mail: mtma@mtmarchetti.com  
 http://www.mtmarchetti.com

PRODUZIONE MODULI ROTANTI



PAGINA SPN360-2-10

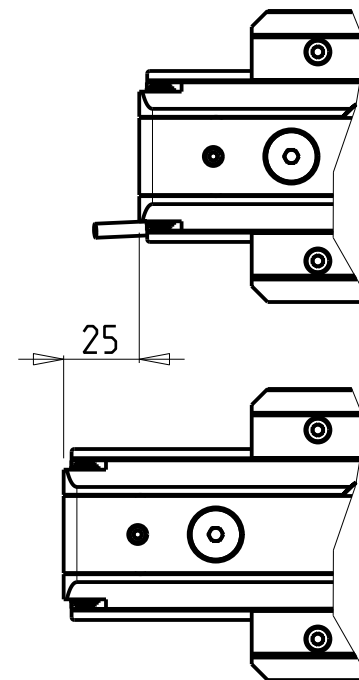
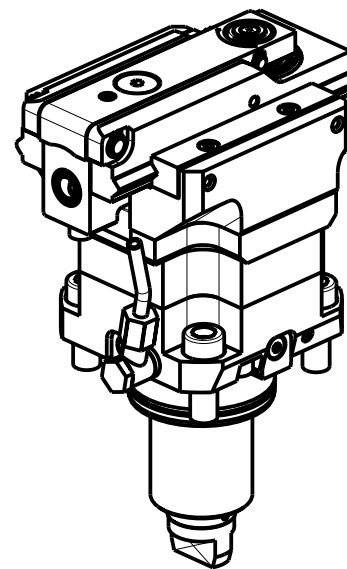
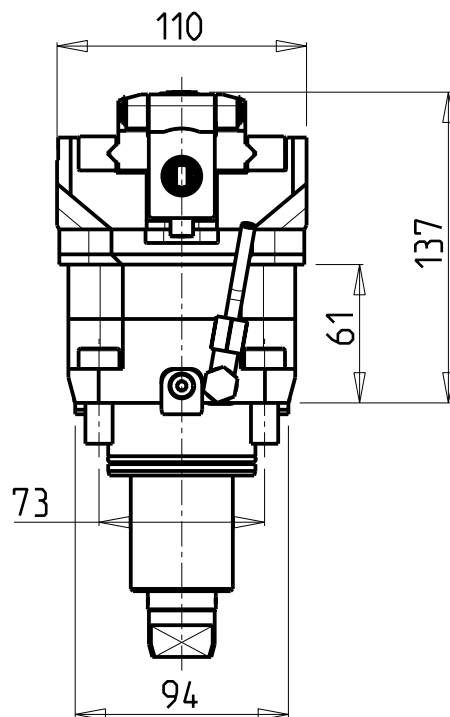
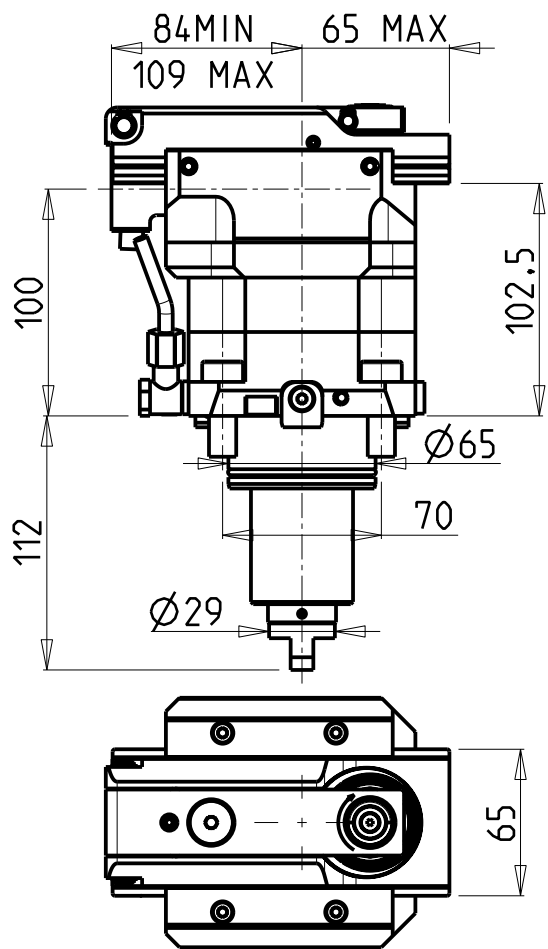

PER UTENSILI STOZZATORI VEDI PAG. TBL400-1-00  
 FOR DRIVEN SLOTTING TOOL CUTTING-TOOLS SEE PAGE TBL400-1-00  
 FÜR NUTENSTOSS-WERKZEUG SCHNEIDWERKZEUGE SIEHE SEITE TBL400-1-00

Cod. MT	I	RPM MAX	Reversibile lato mandrino/contromandrino Reversible sub/main spindle side Umkehrbare Spindel-seite/ Gegenspindel-seite	Lubr. esterna Ext. coolant Aussenkuehlung
DW 01520200	4:1	2400	X	X

**SPINNER**

MOD: TC800 SMCY (BMT65)

MODULO MOTORIZZATO STOZZATORE CORSA 25mm H=100mm

Slotting driven tool 25mm stroke H=100mm

Keilnutenstossmaschine 25mm Hub H=100mm

Subject to change without notice.

**M.T. srl**

Via Casino Albini 480  
 Tel. 0541/956034-957884  
 Fax 0541/956341  
 47842 S. GIOVANNI IN M. (RN)  
 e-mail: mtma@mtmarchetti.com  
 http://www.mtmarchetti.com

PRODUZIONE MODULI ROTANTI



PAGINA SPN360-2-11

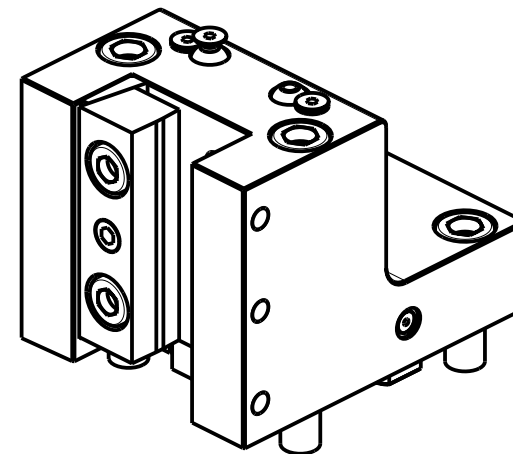
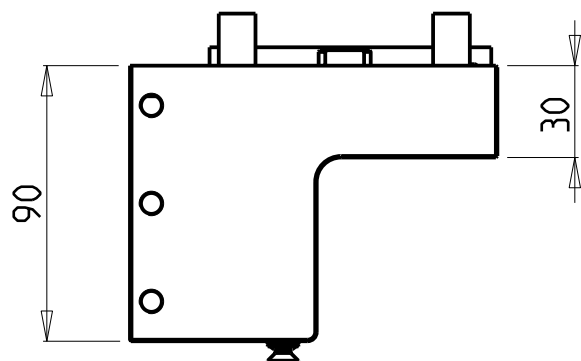
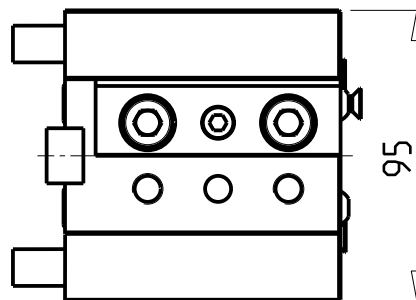
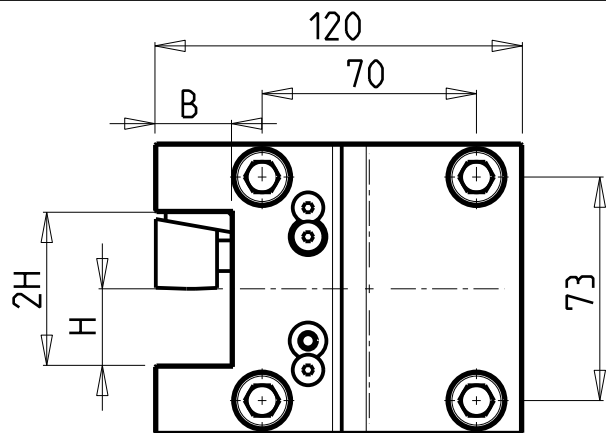

Cod. MT	N°Utensili N°Tools N°Werkzeuge	Reversibile lato mandrino/contromandrino Reversible sub/main spindle side Umkehrbare Spindel- seite/Gegenspindel- seite	Misure Dimensions Masse	B	H
DW00482500	1	X	mm	25	25
DW00482540	1	X	Inch	1"	1"
DW00482000	1	X	mm	20	20

## SPINNER

MOD: TC800 SMCY (BMT65)

PORTAUTENSILE RADIALE SINGOLO QD=25mm / QD=1" / QD=20mm H=90mm

Radial single static tool QD=25mm / QD=1" / QD=20mm H=90mm

Radial Single-Werkzeughalter QD=25mm / QD=1" / QD=20mm H=90mm

Subject to change without notice.

**M.T. srl**

Via Casino Albini 480  
Tel. 0541/956034-957884  
Fax 0541/956341

47842 S. GIOVANNI IN M. (RN)  
e-mail: mtma@mtmarchetti.com  
http://www.mtmarchetti.com

PRODUZIONE MODULI ROTANTI



PAGINA SPN423-2-00

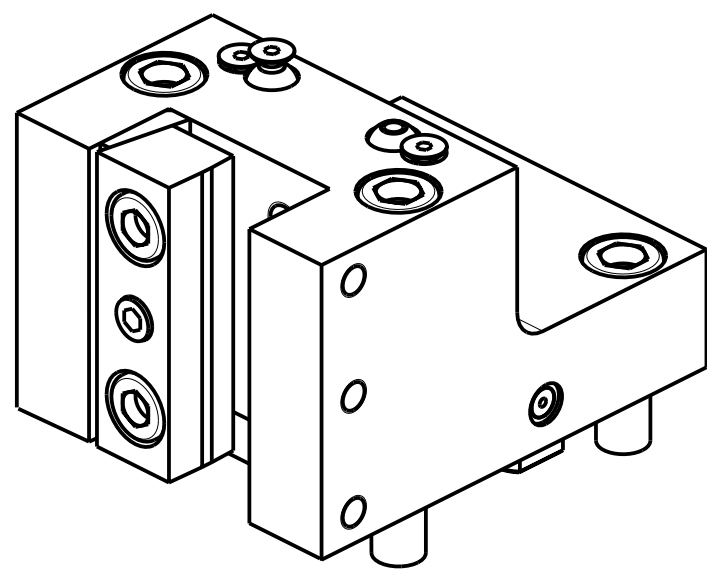
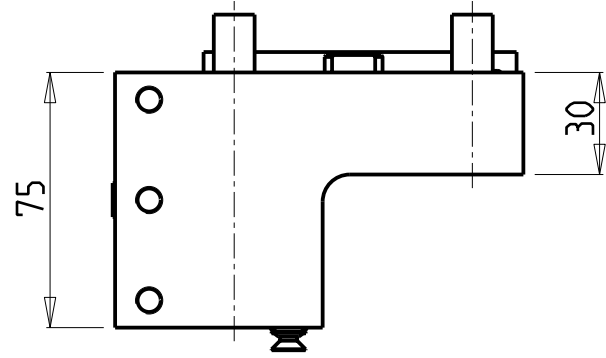
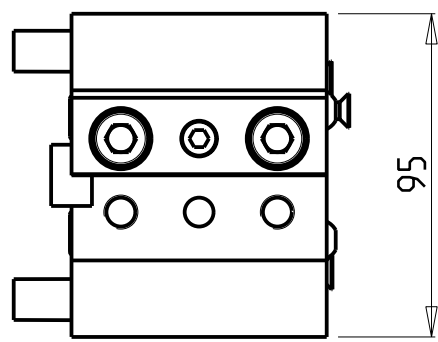
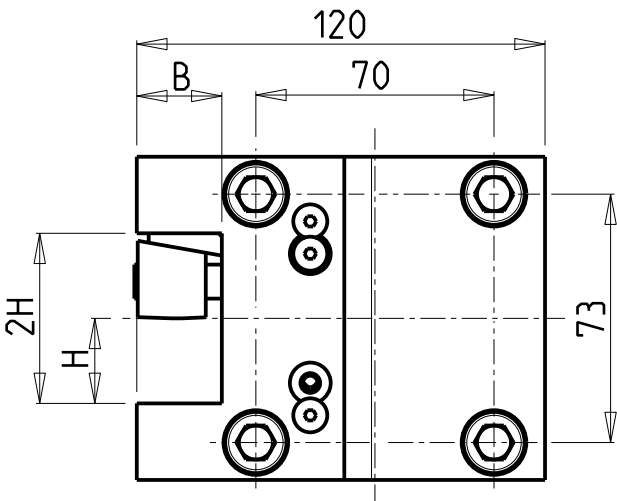

Cod. MT	N°Utensili N°Tools N°Werkzeuge	Reversibile lato mandrino/contromandrino Reversible sub/main spindle side Umkehrbare Spindel-seite/ Gegenspindel-seite	Misure Dimensions Masse	B	H
DW01422500	1	X	mm	25	25
DW01422540	1	X	Inch	1"	1"

**SPINNER**  
MOD: TC800 SMCY (BMT65)

PORTAUTENSILE RADIALE SINGOLO QD=25mm / QD=1" H=75mm  
Radial single static tool QD=25mm / QD=1" H=75mm  
Radial Single-Werkzeughalter QD=25mm / QD=1" H=75mm

Subject to change without notice.

**M.T. srl**  
Via Casino Albini 480  
Tel. 0541/956034-957884  
Fax 0541/956341  
47842 S. GIOVANNI IN M. (RN)  
e-mail: mtma@mtmarchetti.com  
<http://www.mtmarchetti.com>

PRODUZIONE MODULI ROTANTI  

PAGINA SPN423-2-10



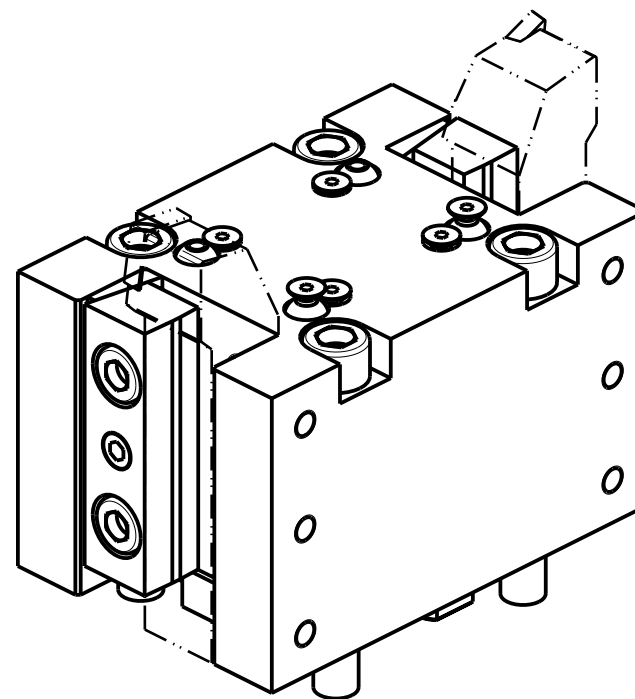
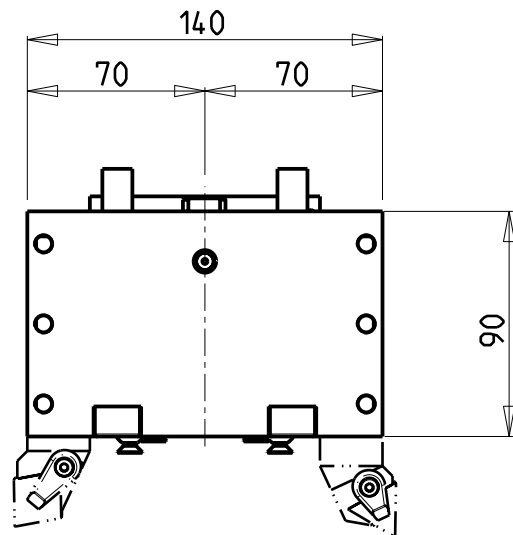
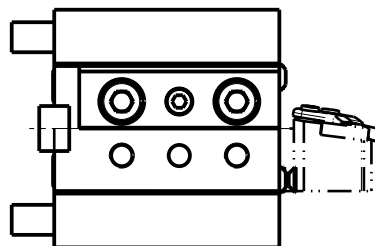
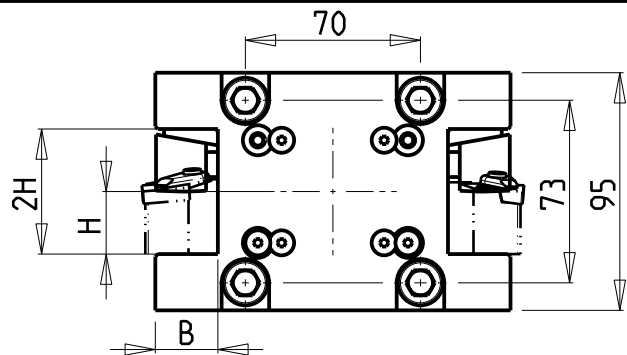

Cod. MT	N°Utensili N° Tools N° Werkzeuge	Reversibile lato mandrino/contromandrino Reversible sub/main spindle side Umkehrbare Spindel-seite/ Gegenspindel-seite	Misure Dimensions Masse	B	H
DW00272500	2/4	X	mm	25	25
DW00272540	2/4	X	Inch	1"	1"
DW00272000	2/4	X	mm	20	20

## SPINNER

MOD: TC800 SMCY (BMT65)

PORTAUTENSILE RADIALE DOPPIO QD=25mm / QD=1" / QD=20mm H=90mm

Radial double static tool QD=25mm / QD=1" / QD=20mm H=90mm

Radial Doppel-Werkzeughalter QD=25mm / QD=1" / QD=20mm H=90mm

Subject to change without notice.

**M.T. srl**

Via Casino Albini 480  
Tel. 0541/956034-957884  
Fax 0541/956341

47842 S. GIOVANNI IN M. (RN)  
e-mail: mtma@mtmarchetti.com  
http://www.mtmarchetti.com

PRODUZIONE MODULI ROTANTI



PAGINA SPN453-2-00

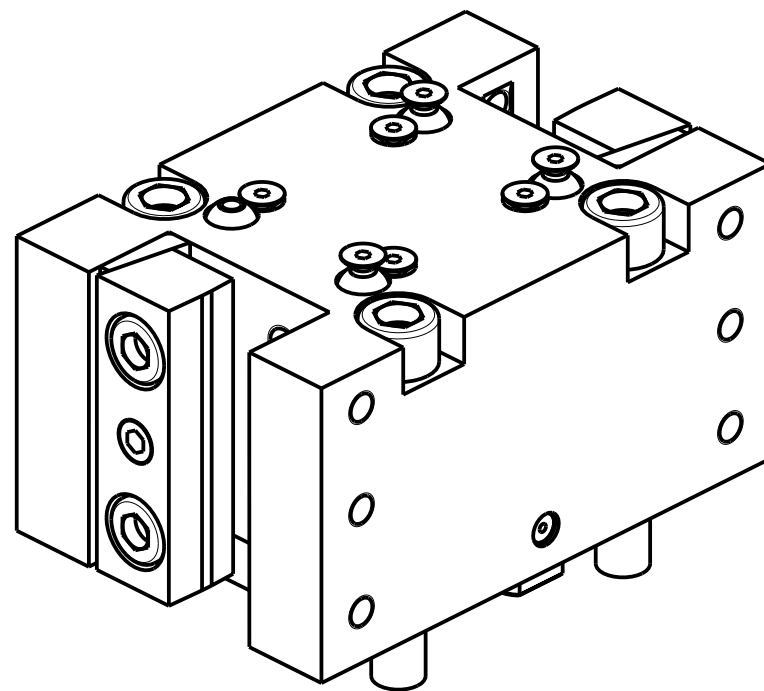
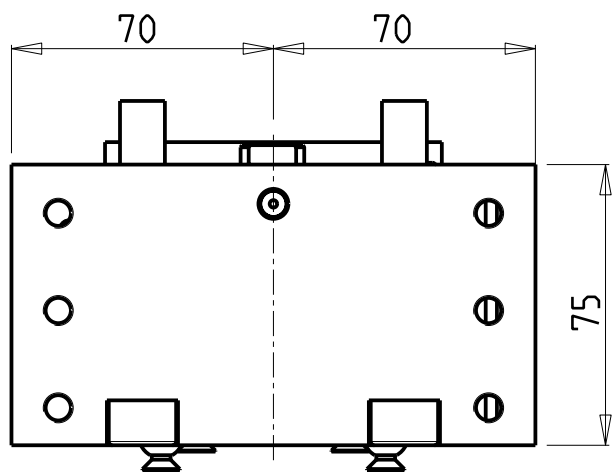
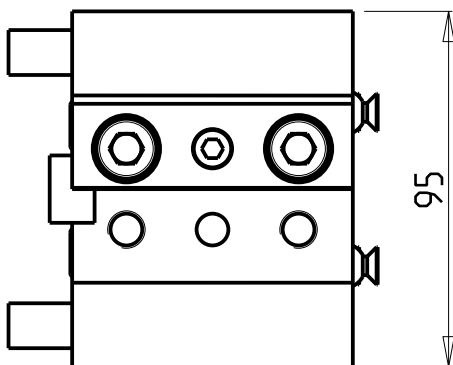
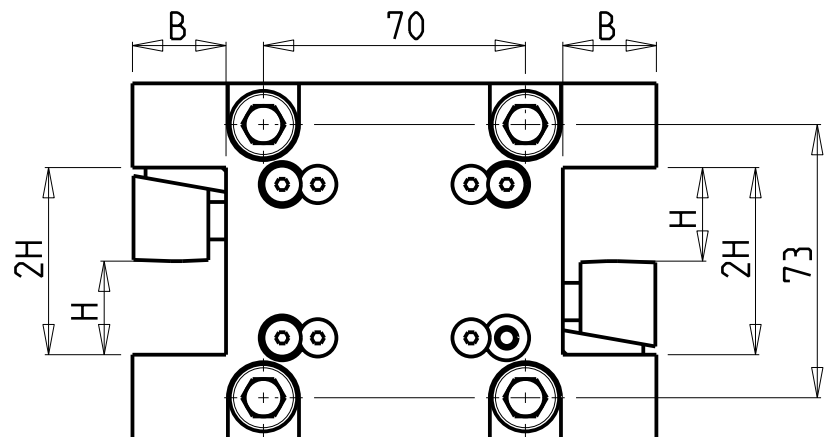

Cod. MT	N°Utensili N°Tools N°Werkzeuge	Reversibile lato mandrino/contromandrino Reversible sub/main spindle side Umkehrbare Spindel-seite/ Gegenspindel-seite	Misure Dimensions Masse	B	H
DW00672500	2/4	X	mm	25	25
DW00672000	2/4	X	mm	20	20

## SPINNER

MOD: TC800 SMCY (BMT65)

PORTAUTENSILE RADIALE DOPPIO QD=25mm / QD=20mm H=75mm

Radial double static tool QD=25mm / QD=20mm H=75mm

Radial Doppel-Werkzeughalter QD=25mm / QD=20mm H=75mm

Subject to change without notice.

## M.T. srl

Via Casino Albini 480  
Tel. 0541/956034-957884  
Fax 0541/956341

47842 S. GIOVANNI IN M. (RN)  
e-mail: mtma@mtmarchetti.com  
http://www.mtmarchetti.com

PRODUZIONE MODULI ROTANTI



PAGINA SPN453-2-10

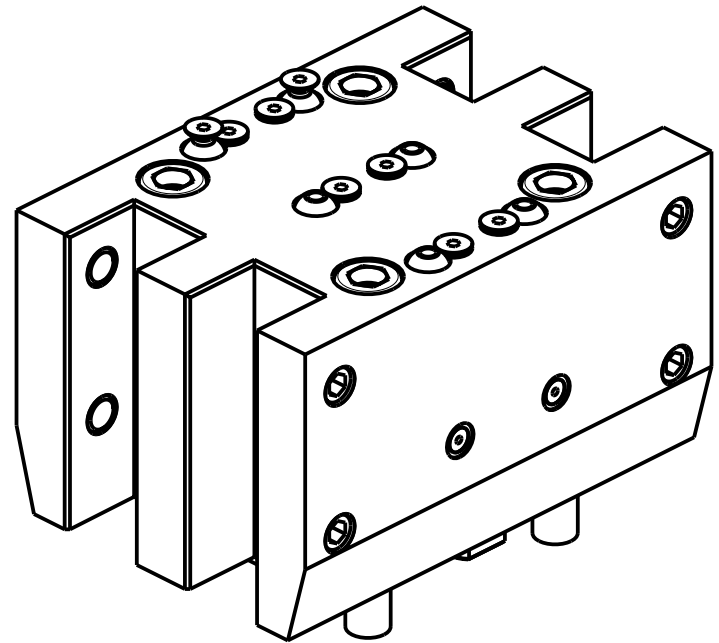
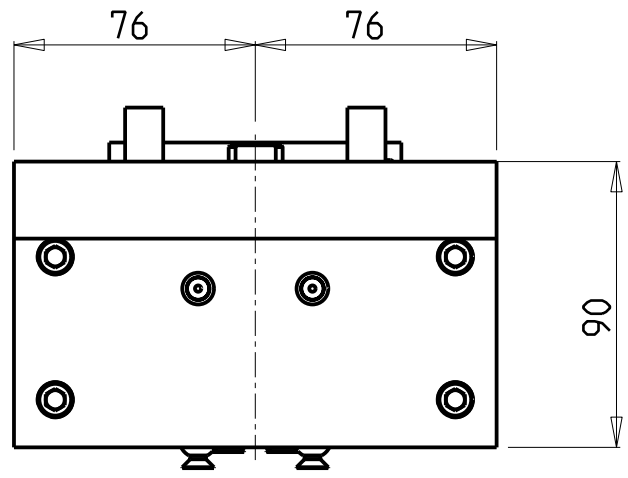
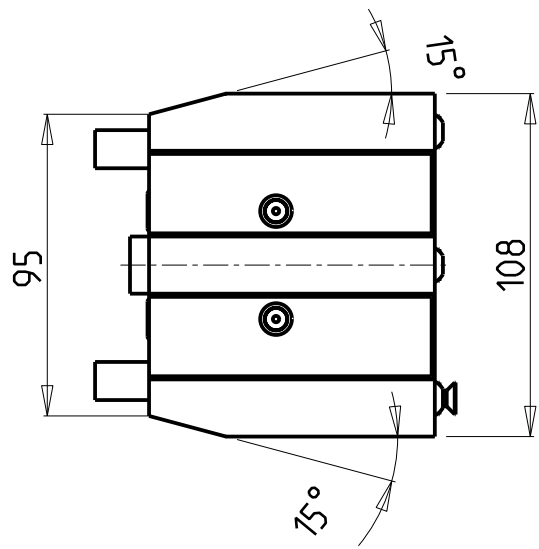
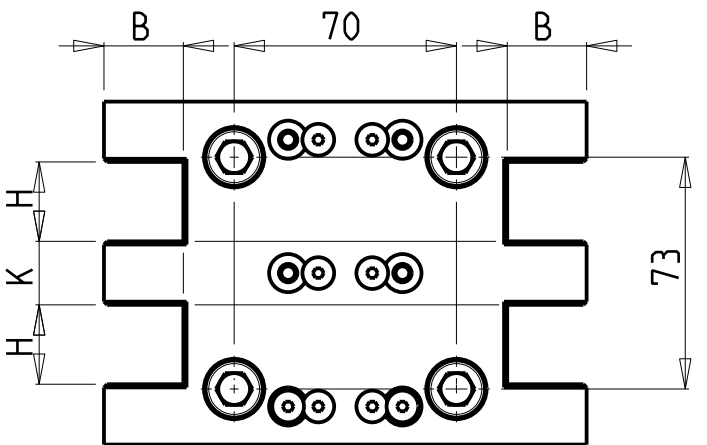

Cod. MT	N°Utensili N° Tools N°Werkzeuge	Reversibile lato mandrino/contromandrino Reversible sub/main spindle side Umkehrbare Spindel-seite/ Gegenspindel-seite	Misure Dimensions Masse	H	K	B
DW00622500	4	X	mm	25	20	25
DW00622540	4	X	inch	1"	3/4"	1"

**SPINNER**  
**MOD: TC800 SMCY (BMT65)**

**PORTAUTENSILE RADIALE DOPPIO SOVRAPPOSTO QD=25mm / QD=1"**  
**Radial double side twin static tool QD=25mm / QD=1"**  
**Radial Doppel-Werkzeughalter ueberlagert QD=25mm / QD=1"**

Subject to change without notice.

**M.T. srl**  
 Via Casino Albini 480  
 Tel. 0541/956034-957884  
 Fax 0541/956341  
 47842 S. GIOVANNI IN M. (RN)  
 e-mail: mtma@mtmarchetti.com  
 http://www.mtmarchetti.com

PRODUZIONE MODULI ROTANTI



PAGINA SPN463-2-00

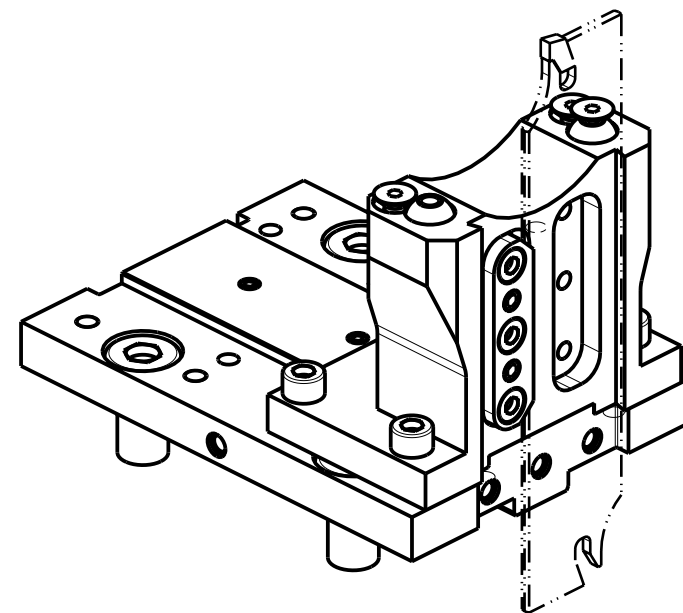
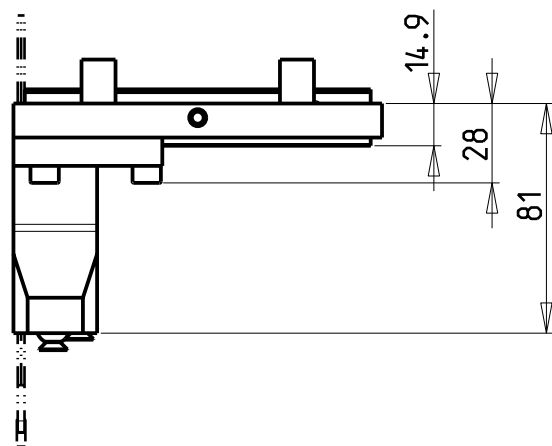
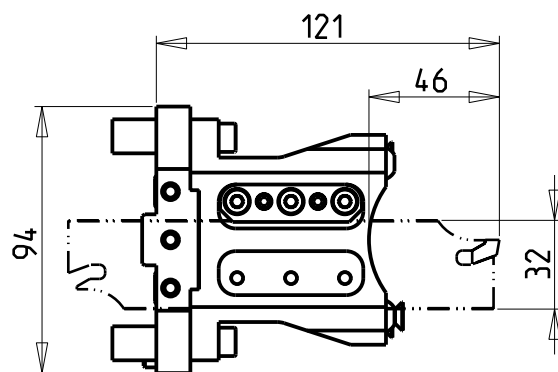
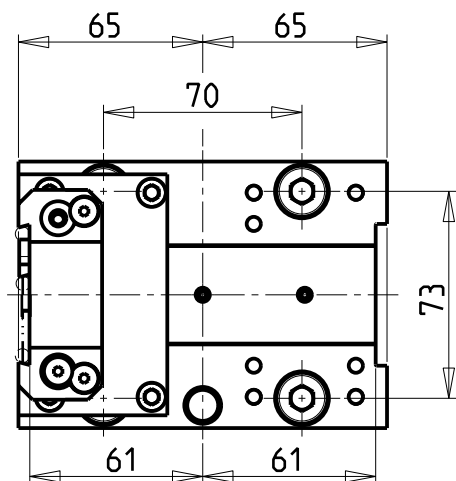

POSSIBILITA' DI LAVORO M3/M4  
 OPTION OF M3/M4 WORKING  
 ARBEITSMÖGLICHKEIT M3/M4

**DOTAZIONI - SUPPLIED WITH - AUSSTATTUNG**

N°1 - LAMA - BLADE - KLINGE ISCAR H=32 Sp. 3/4mm  
 (KENNAMETAL OPTIONAL)

N°10 - INSERTI - INSERTS - EINLAGEN

N°1 - CHIAVE A T PER MONTAGGIO INSERTI  
 - T-WRENCH FOR INSERT SET UP  
 - T-SCHLUESSEL FUER EINSATZSTUECK-MONTAGE

Cod. MT	N°Utensili N°Tools N°Werkzeuge	Reversibile lato mandrino/contromandrino Reversible sub/main spindle side Umkehrbare Spindel-seite/ Gegenspindel-seite	Lubr.esterna Ext. coolant Aussehenkuehlung
DW 014 10132	1	X	X

SPINNER

MOD: TC800 SMCY (BMT65)

PORTAUTENSILE RADIALE PER LAMA

Radial blade holder

Radial Abstechhalter

Subject to change without notice.

**M.T. srl**

Via Casino Albini 480  
 Tel. 0541/956034-957884  
 Fax 0541/956341  
 47842 S. GIOVANNI IN M. (RN)  
 e-mail: mtma@mtmarchetti.com  
 http://www.mtmarchetti.com

PRODUZIONE MODULI ROTANTI



PAGINA SPN520-2-01

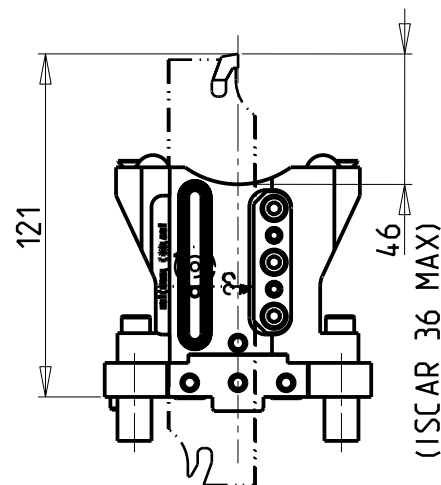
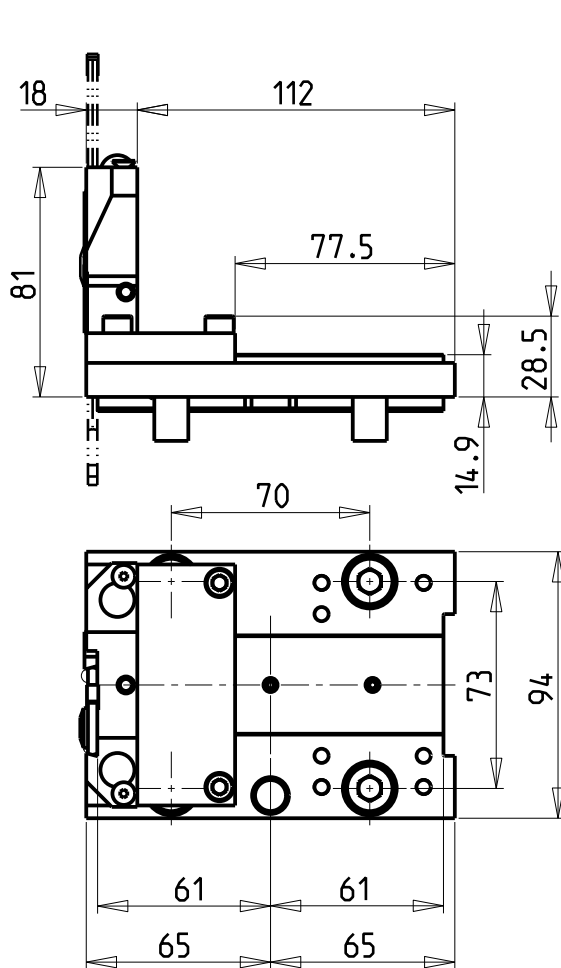

versione dx  
right version  
version rechts

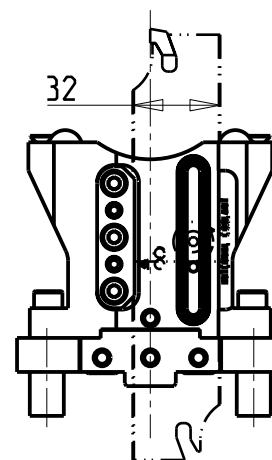

versione sx  
left version  
version links

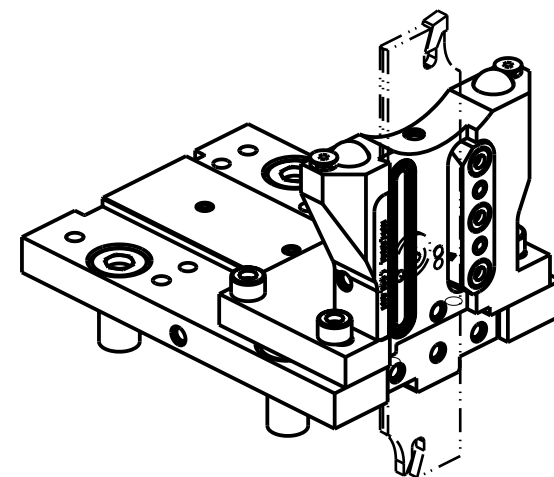

**KIT LAME NON INCLUSI (OPZIONALI)  
BLADES NOT SUPPLIED WITH (OPTIONAL)  
KLINGEN NICHT INBEGRIFFEN (OPTIONAL)**

- LAMA-BLADE-KLINGE SANDVIK H=32 sp.3 cod. QD\_NN2G60C 25A  
+INSERTI-INSERTS-EINLAGEN cod. QD\_NG\_0300\_0002\_CM\_1145 (10 pz.)
- LAMA-BLADE-KLINGE SANDVIK H=32 sp.4 cod. QD\_NN2H60C 25A  
+INSERTI-INSERTS-EINLAGEN cod. QD\_NH\_0400\_0002\_CM\_1145 (10 pz.)
- LAMA-BLADE-KLINGE ISCAR H=32 sp.3 cod. SGFH\_32K\_3  
+INSERTI-INSERTS-EINLAGEN cod. 6011365 (10pz.)
- LAMA-BLADE-KLINGE ISCAR H=32 sp.4 cod. SGFH\_32K\_4  
+INSERTI-INSERTS-EINLAGEN cod. 6011366 (10pz.)
- LAMA-BLADE-KLINGE WALTER H=32 sp.3 cod. G2042.32N-3T45SX-P  
+INSERTI-INSERTS-EINLAGEN cod. SX-3E300N02-CE4 WSM33S (10pz.) + CHIAVE-KEY cod. FS1494
- LAMA-BLADE-KLINGE WALTER H=32 sp.4 cod. G2042.32N-4T50SX-P  
+INSERTI-INSERTS-EINLAGEN cod. SX-4E400N02-CE4 WSM33S (10pz.) + CHIAVE-KEY cod. FS1494

Cod. MT

versione dx  
right version  
version rechts

versione sx  
left version  
version links

DW 01730132R

DW 01730132L

N°Utensili  
N°Tools  
N°Werkzeuge

1

Reversibile lato  
mandrino/contromandrino  
Reversible sub/main  
spindle side  
Umkehrbare Spindel-seite/  
Gegenspindel-seite

X

Lubr.esterna  
Ext. coolant  
Auslenkuehlung

X

Lubr.interna  
Coolant through  
Innenkuehlung

P=70bar

SPINNER

MOD: TC800 SMCY (BMT65)

PORTAUTENSILE RADIALE PER LAMA CON LUBRIFICAZIONE INTERNA

Radial blade holder with internal coolant

Radial Abstechhalter mit Innenkuehlung

Subject to change without notice.

**M.T. srl**

Via Casino Albini 480  
Tel. 0541/956034-957884

Fax 0541/956341

47842 S. GIOVANNI IN M. (RN)

e-mail: mtma@mtmarchetti.com

http://www.mtmarchetti.com

PRODUZIONE MODULI ROTANTI



PAGINA SPN520-2-05

10/2018

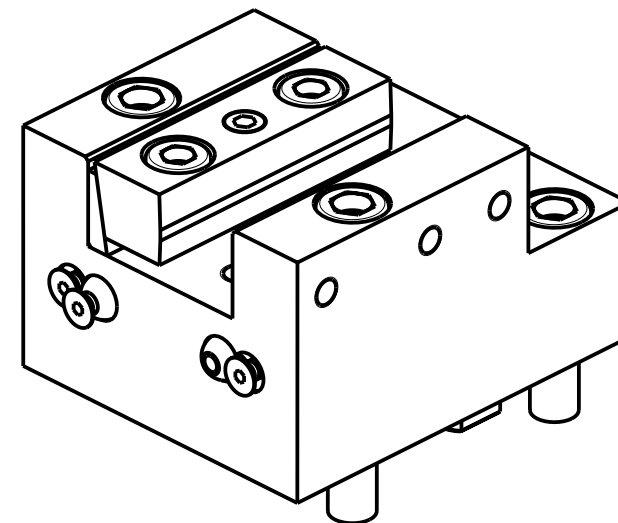
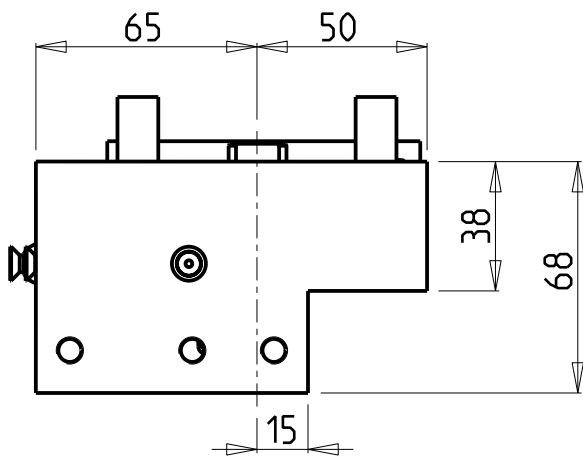
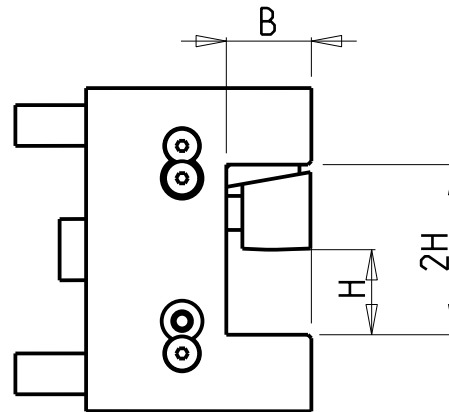
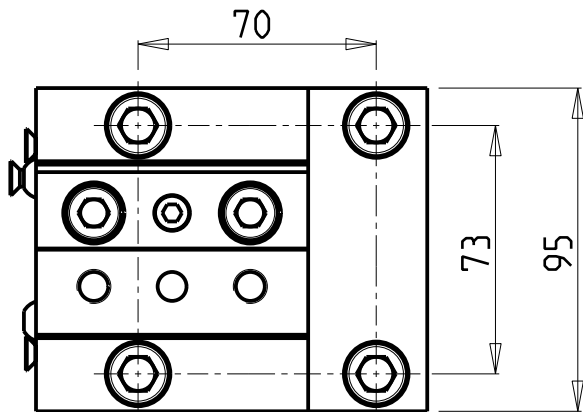

Cod. MT	N°Utensili N°Tools N°Werkzeuge	Reversibile lato mandrino/contromandrino Reversible sub/main spindle side Umkehrbare Spindel-seite/ Gegenspindel-seite	Misure Dimensions Masse	B	H
DW01452500	1	X	mm	25	25
DW01452540	1	X	Inch	1"	1"

## SPINNER

MOD: TC800 SMCY (BMT65)

PORTAUTENSILE ASSIALE SINGOLO QD=25mm / QD=1"

Axial single static tool QD=25mm / QD=1"

Axial Single-Werkzeughalter QD=25mm / QD=1"

Subject to change without notice.

**M.T. srl**

Via Casino Albini 480  
Tel. 0541/956034-957884  
Fax 0541/956341  
47842 S. GIOVANNI IN M. (RN)  
e-mail: mtma@mtmarchetti.com  
<http://www.mtmarchetti.com>

PRODUZIONE MODULI ROTANTI



PAGINA SPN552-2-00

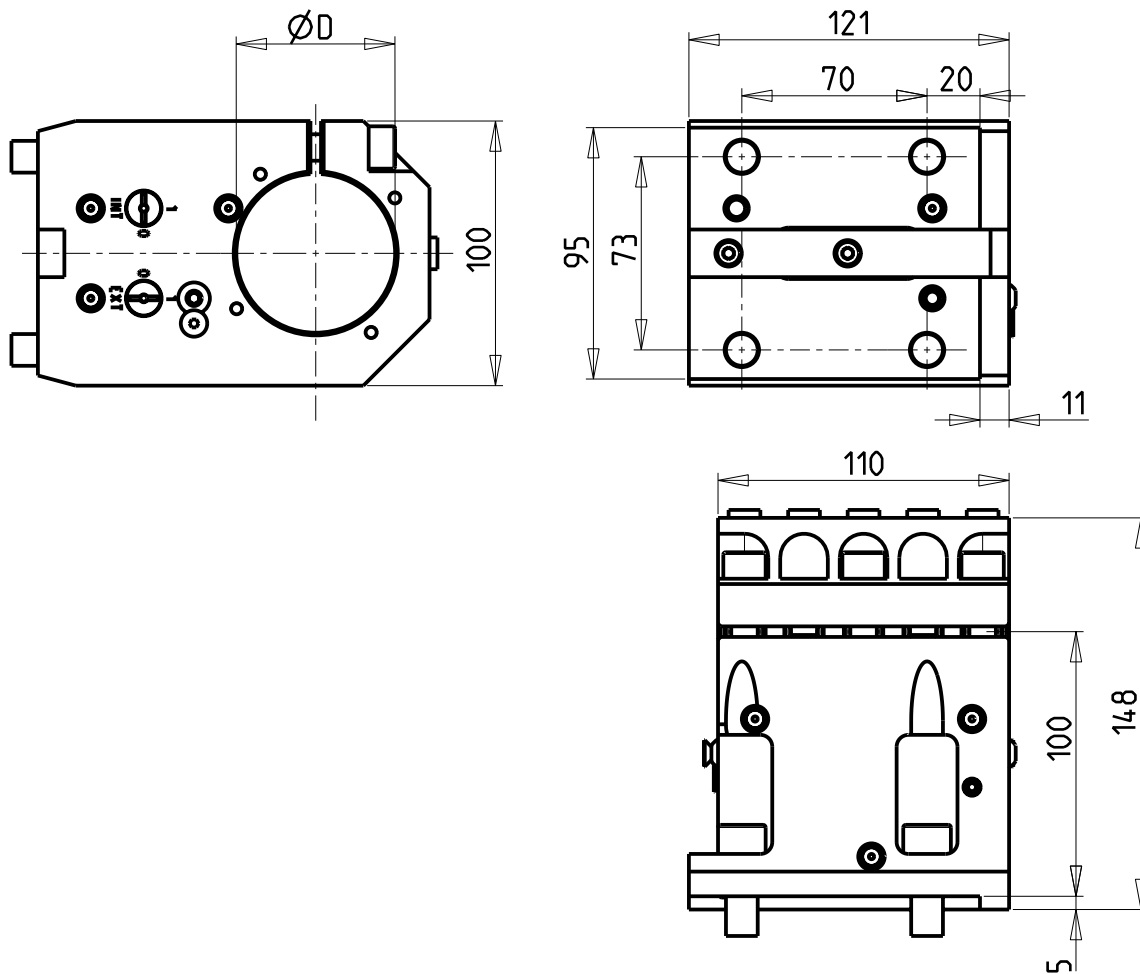

KIT ADDUZIONE INTERNA (OPZIONALE)  
 KIT FOR INTERNAL COOLANT (OPTIONAL)  
 KIT FUER INTERNE KUEHLMITTELZUFUHR (OPTIONAL)  
 Ø60 cod. KIT1003025

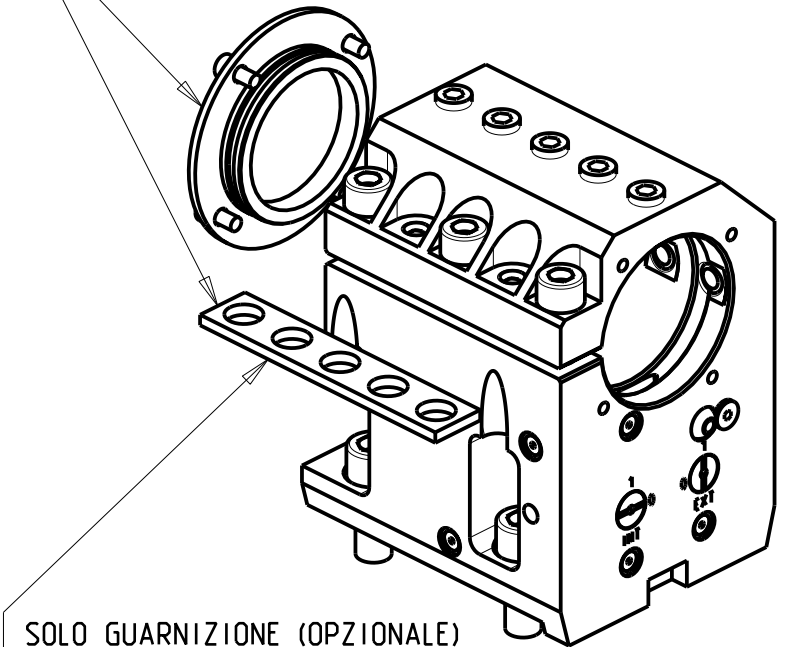

SOLO GUARNIZIONE (OPZIONALE)  
 ONLY SEAL (OPTIONAL) NUR  
 DICHTUNG (OPTIONAL) cod.  
 0520013

PER BOCCOLE DI RIDUZIONE VEDI PAG. TBL150-1-00  
 FOR REDUCING BUSHINGS SEE PAGE TBL150-1-00  
 FUR REDUZIERBUCHSE SIEHE SEITE TBL150-1-00

Cod. MT	N°Utensili N°Tools N°Werkzeuge	Reversibile lato mandrino/contromandrino Reversible sub/main spindle side Umkehrbare Spindel-seite/ Gegenspindel-seite	Lubrificazione int. opzionale Coolant through optional Innenkuehlung Optional	Lubrificazione est. Ext. coolant Aussenkuehlung	Misure Dimensions Masse	D
DW00746000	1	X	X	X	mm	60

SPINNER

MOD: TC800 SMCY (BMT65)

PORTAUTENSILE ASSIALE PER BARENO Ø60mm H=100mm

Axial single boring bar holder Ø60mm H=100mm

Axial Bohrhälter Ø60mm H=100mm

Subject to change without notice.

**M.T. srl**

Via Casino Albini 480  
 Tel. 0541/956034-957884  
 Fax 0541/956341  
 47842 S. GIOVANNI IN M. (RN)  
 e-mail: mtma@mtmarchetti.com  
 http://www.mtmarchetti.com

PRODUZIONE MODULI ROTANTI



PAGINA SPN590-2-20

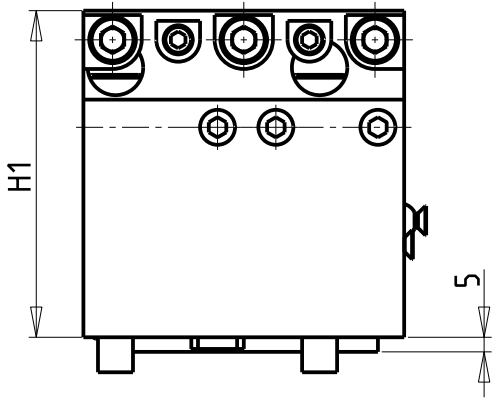
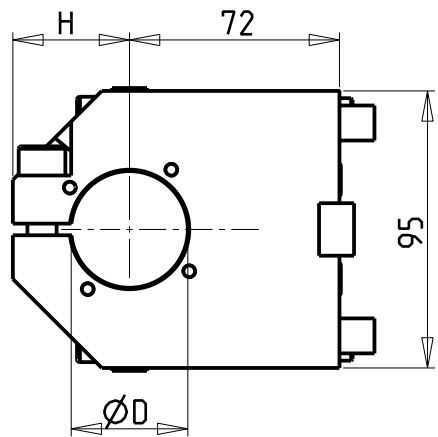
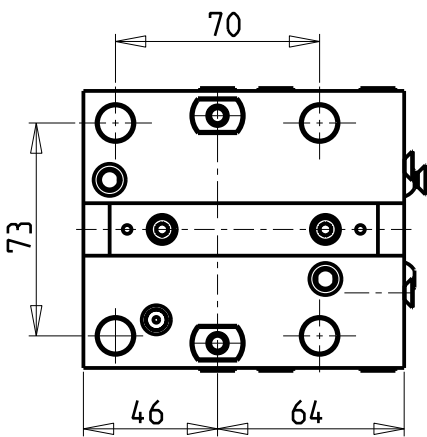

KIT ADDUZIONE INTERNA (OPZIONALE)  
 KIT FOR INTERNAL COOLANT (OPTIONAL)  
 KIT FUER INTERNE KUEHLMITTELZUFUHR (OPTIONAL)  
 Ø1 1/2" cod. KIT1003004  
 Ø40 cod. KIT1003003  
 Ø50-Ø2" cod. KIT1003002

SOLO GUARNIZIONE (OPZIONALE)  
 ONLY SEAL (OPTIONAL)  
 NUR DICHTUNG (OPTIONAL)  
 cod. 0520013

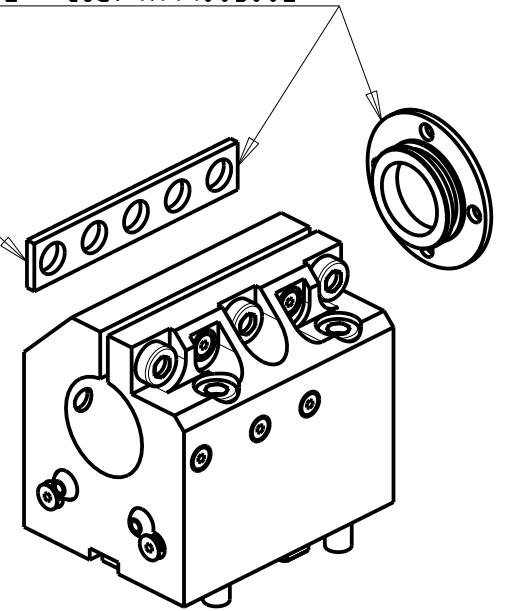

PER BOCCOLE DI RIDUZIONE VEDI PAG. TBL150-1-00  
 FOR REDUCING BUSHINGS SEE PAGE TBL150-1-00  
 FÜR REDUZIERBUCHSE SIEHE SEITE TBL150-1-00

Cod. MT	N°Utensili N°Tools N°Werkzeuge	Reversibile lato mandrino/contromandrino Reversible sub/main spindle side Umkehrbare Spindel-seite/ Gegenspindel-seite	Lubrificazione int. opzionale Coolant through optional Innenkuehlung Optional	Lubrificazione est. Ext. coolant Aussenkuehlung	Misure Dimensions Masse	D	H	H1
0834000	1	X	X	X	mm	40	40	112
0833810	1	X	X	X	Inch	1 1/2"	40	112
0835000	1	X	X	X	mm	50	46.5	118
0835080	1	X	X	X	Inch	2"	46.5	118

SPINNER  
 MOD: TC800 SMCY (BMT65)

PORTAUTENSILE ASSIALE PER BARENO Ø40mm/Ø1 1/2"/Ø50mm/Ø2" H=72mm  
 Axial single boring bar holder Ø40mm/Ø1 1/2"/Ø50mm/Ø2" H=72mm  
 Axial Bohrhälter Ø40mm/Ø1 1/2"/Ø50mm/Ø2" H=72mm

Subject to change without notice.

**M.T. srl**  
 Via Casino Albini 480  
 Tel. 0541/956034-957884  
 Fax 0541/956341  
 47842 S. GIOVANNI IN M. (RN)  
 e-mail: mtma@mtmarchetti.com  
 http://www.mtmarchetti.com

PRODUZIONE MODULI ROTANTI



PAGINA SPN610-2-20



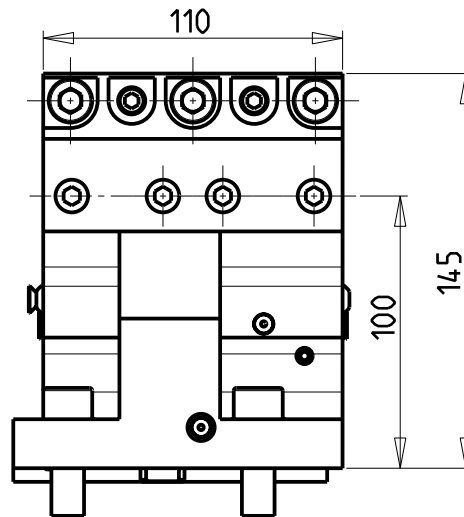
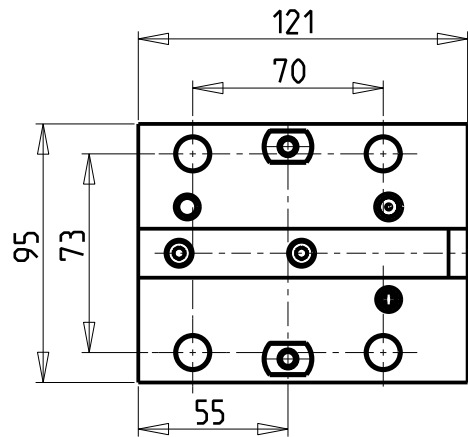
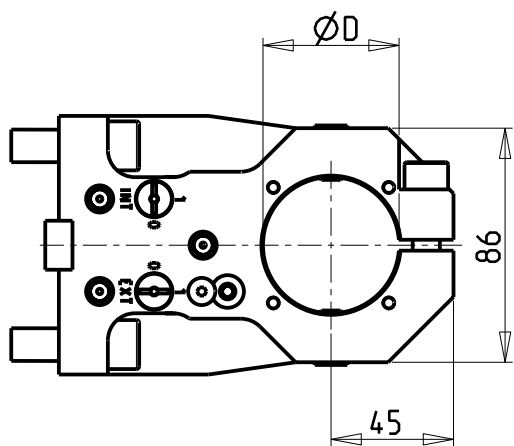

KIT ADDUZIONE INTERNA (OPZIONALE)  
 KIT FOR INTERNAL COOLANT (OPTIONAL)  
 KIT FUER INTERNE KUEHLMITTELZUFUHR (OPTIONAL)  
 Ø50 cod. KIT1003002

SOLO GUARNIZIONE (OPZIONALE)  
 ONLY SEAL (OPTIONAL)  
 NUR DICHTUNG (OPTIONAL)  
 cod. 0520013

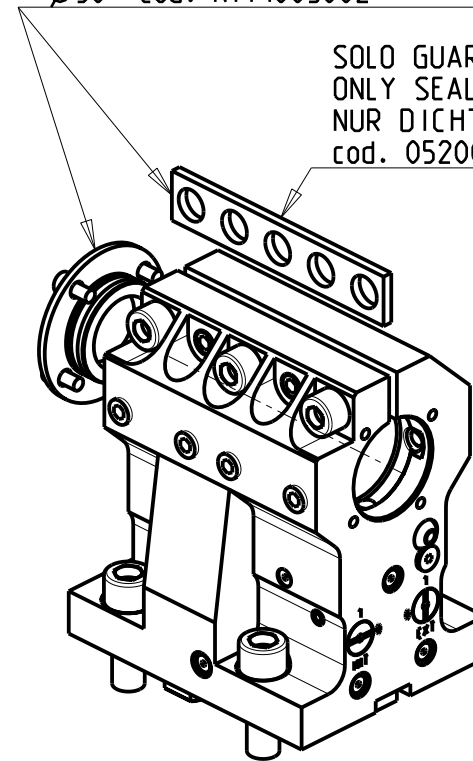

PER BOCCOLE DI RIDUZIONE VEDI PAG. TBL150-1-00  
 FOR REDUCING BUSHINGS SEE PAGE TBL150-1-00  
 FÜR REDUZIERBUCHSE SIEHE SEITE TBL150-1-00

Cod. MT	N°Utensili N°Tools N°Werkzeuge	Reversibile lato mandrino/contromandrino Reversible sub/main spindle side Umkehrbare Spindel-seite/ Gegenspindel-seite	Lubrificazione int. opzionale Coolant through optional Innenkuehlung Optional	Lubrificazione est. Ext. coolant Aussenkuehlung	Misure Dimensions Masse	D
DW00205000	1	X	X	X	mm	50

## SPINNER

MOD: TC800 SMCY (BMT65)

PORTAUTENSILE ASSIALE PER BARENO Ø50mm H=100mm

Axial single boring bar holder Ø50mm H=100mm

Axial Bohrhälter Ø50mm H=100mm

Subject to change without notice.

**M.T. srl**

Via Casino Albini 480  
 Tel. 0541/956034-957884  
 Fax 0541/956341  
 47842 S. GIOVANNI IN M. (RN)  
 e-mail: mtma@mtmarchetti.com  
 http://www.mtmarchetti.com

PRODUZIONE MODULI ROTANTI



PAGINA SPN620-2-20

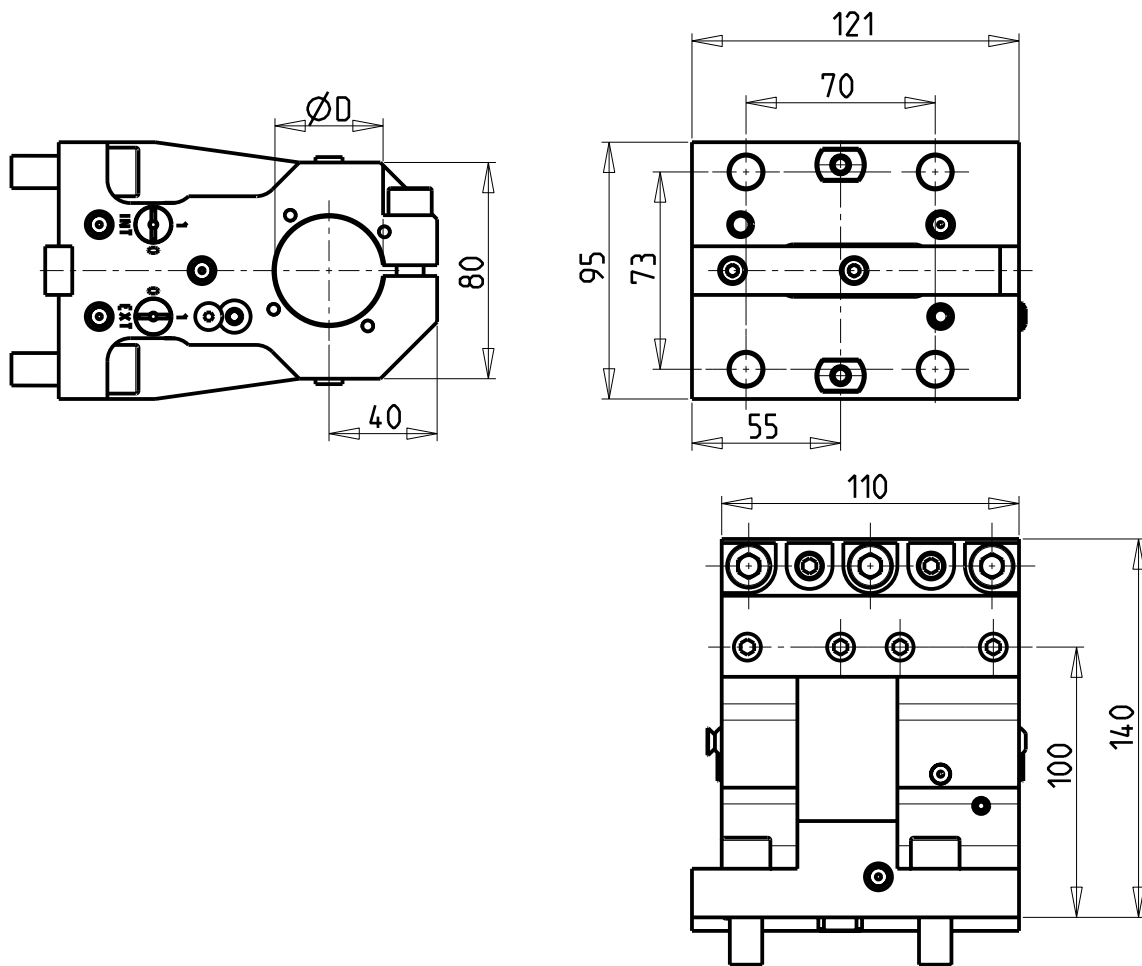

KIT ADDUZIONE INTERNA (OPZIONALE)  
 KIT FOR INTERNAL COOLANT (OPTIONAL)  
 KIT FUER INTERNE KUEHLMITTELZUFUHR (OPTIONAL)  
 Ø40 cod. KIT1003003

SOLO GUARNIZIONE (OPZIONALE)  
 ONLY SEAL (OPTIONAL)  
 NUR DICHTUNG (OPTIONAL)  
 cod. 0520013

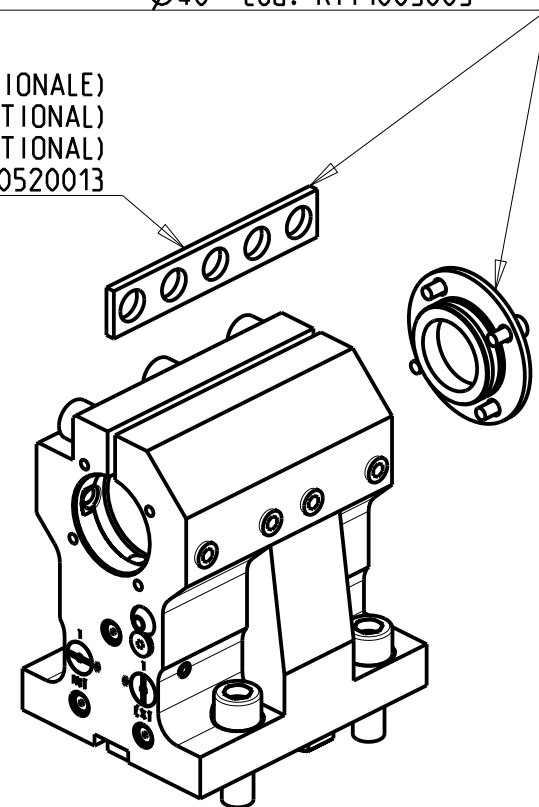

PER BOCCOLE DI RIDUZIONE VEDI PAG. TBL150-1-00  
 FOR REDUCING BUSHINGS SEE PAGE TBL150-1-00  
 FUR REDUZIERBUCHSE SIEHE SEITE TBL150-1-00

Cod. MT	N°Utensili N°Tools N°Werkzeuge	Reversibile lato mandrino/contromandrino Reversible sub/main spindle side Umkehrbare Spindel-seite/ Gegenspindel-seite	Lubrificazione int. opzionale Coolant through optional Innenkuehlung Optional	Lubrificazione est. Ext. coolant Aussenkuehlung	Misure Dimensions Masse	D
DW00204000	1	X	X	X	mm	40

## SPINNER

MOD: TC800 SMCY (BMT65)

PORTAUTENSILE ASSIALE PER BARENO Ø40mm H=100mm

Axial single boring bar holder Ø40mm H=100mm

Axial Bohrhalter Ø40mm H=100mm

Subject to change without notice.

**M.T. srl**

Via Casino Albini 480

Tel. 0541/956034-957884

Fax 0541/956341

47842 S. GIOVANNI IN M. (RN)

e-mail: mtma@mtmarchetti.com

http://www.mtmarchetti.com

PRODUZIONE MODULI ROTANTI



PAGINA SPN640-2-20

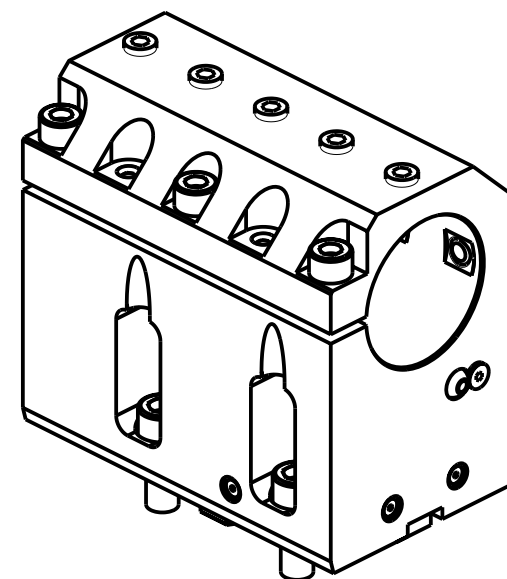
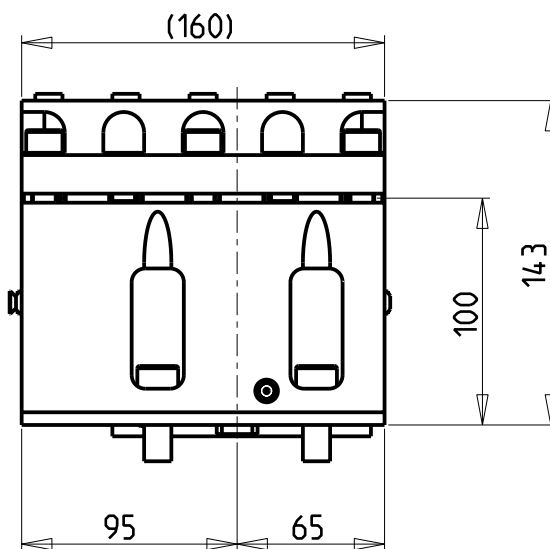
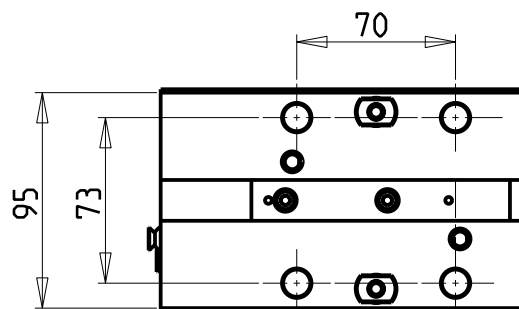
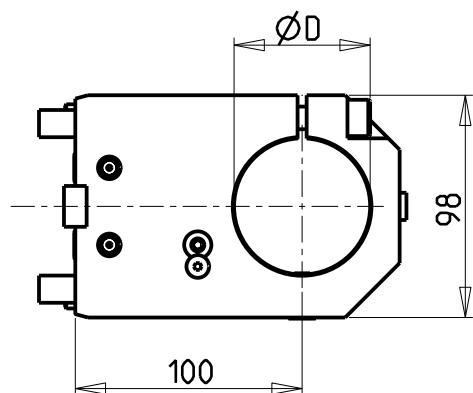

PER BOCCOLE DI RIDUZIONE VEDI PAG. TBL150-1-00  
 FOR REDUCING BUSHINGS SEE PAGE TBL150-1-00  
 FÜR REDUZIERBUCHSE SIEHE SEITE TBL150-1-00

Cod. MT	N°Utensili N°Tools N°Werkzeuge	Reversibile lato mandrino/contromandrino Reversible sub/main spindle side Umkehrbare Spindel-seite/ Gegenspindel-seite	Lubrificazione est. Ext. coolant Aussenkuehlung	Misure Dimensions Masse	D
DW01446000	1	X	X	mm	60

SPINNER

MOD: TC800 SMCY (BMT65)

PORTAUTENSILE ASSIALE PER BARENO Ø60mm H=100mm

Axial single boring bar holder Ø60mm H=100mm

Axial Bohrhälter Ø60mm H=100mm

Subject to change without notice.

**M.T. srl**

Via Casino Albini 480  
 Tel. 0541/956034-957884  
 Fax 0541/956341  
 47842 S. GIOVANNI IN M. (RN)  
 e-mail: mtma@mtmarchetti.com  
 http://www.mtmarchetti.com

PRODUZIONE MODULI ROTANTI



PAGINA SPN720-2-20

KIT ADDUZIONE INTERNA (OPZIONALE)  
 KIT FOR INTERNAL COOLANT (OPTIONAL)  
 KIT FUER INTERNE KUEHLMITTELZUFUHR (OPTIONAL)  
 cod. KIT1000001

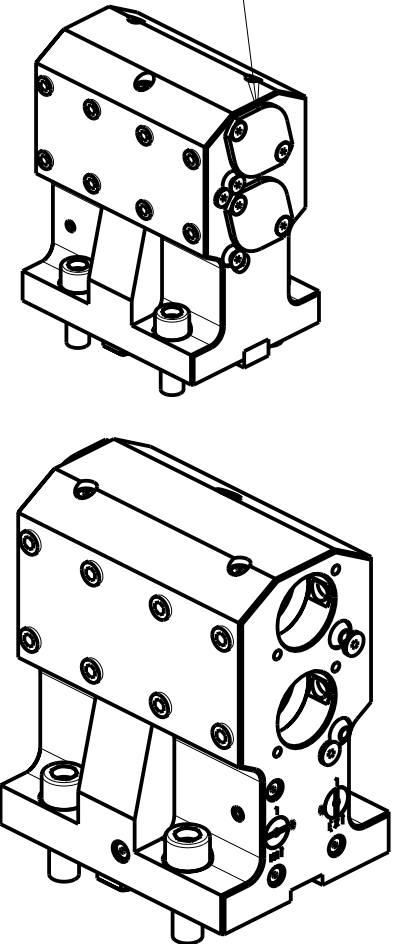
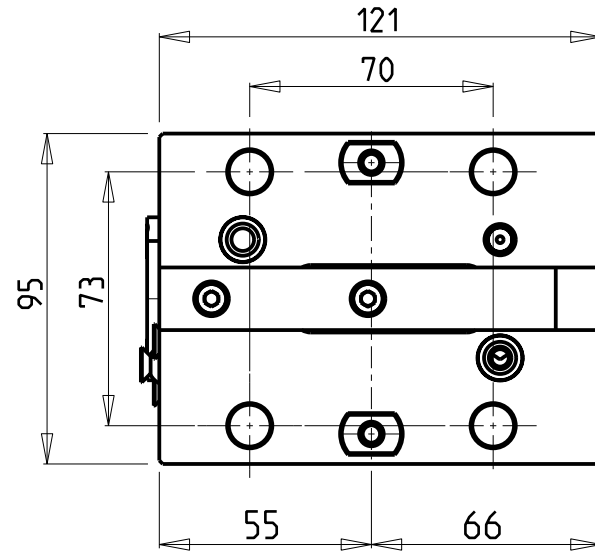
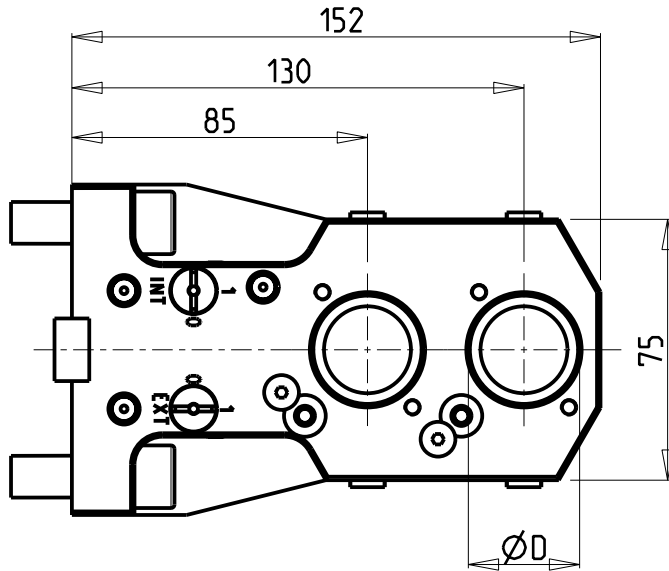

PER BOCCOLE DI RIDUZIONE VEDI PAG. TBL150-1-00  
 FOR REDUCING BUSHINGS SEE PAGE TBL150-1-00  
 FUR REDUZIERBUCHSE SIEHE SEITE TBL150-1-00

Cod. MT	N°Utensili N°Tools N°Werkzeuge	Reversibile lato mandrino/contromandrino Reversible sub/main spindle side Umkehrbare Spindel-seite/ Gegenspindel-seite	Lubrificazione int. opzionale Coolant through optional Innenkuehlung Optional	Lubrificazione est. Ext. coolant Aussenkuehlung	Misure Dimensions Masse	D
DW00213200	2+2	X	X	X	mm	32
DW00213175	2+2	X	X	X	Inch	1 1/4"

SPINNER

MOD: TC800 SMCY (BMT65)

PORTAUTENSILE ASSIALE PER BARENO 2 POSIZIONI Ø32mm / Ø1 1/4"

Axial double boring bar holder Ø32mm / Ø1 1/4"

Axial Bohrhälter 2 Positionen Ø32mm / Ø1 1/4"

Subject to change without notice.

**M.T. srl**

Via Casino Albini 480  
 Tel. 0541/956034-957884  
 Fax 0541/956341  
 47842 S. GIOVANNI IN M. (RN)  
 e-mail: mtma@mtmarchetti.com  
 http://www.mtmarchetti.com

PRODUZIONE MODULI ROTANTI



PAGINA SPN862-2-00

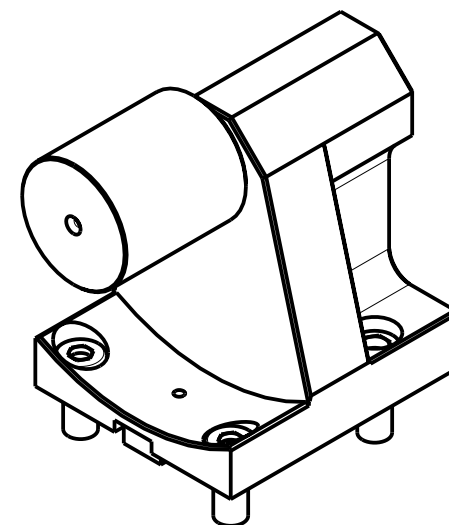
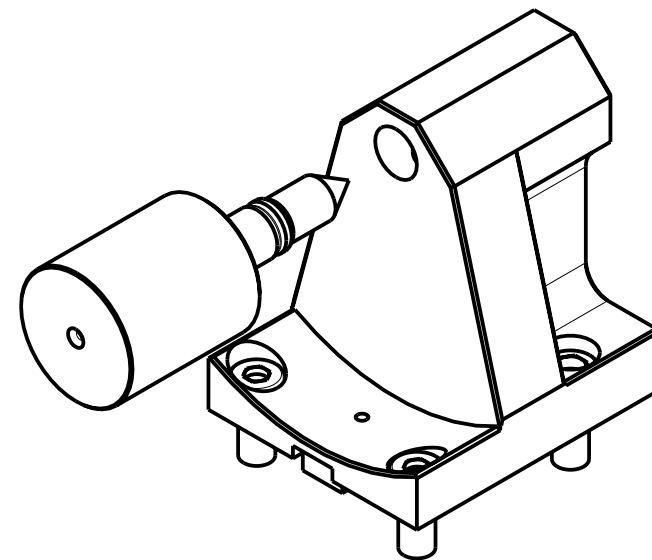
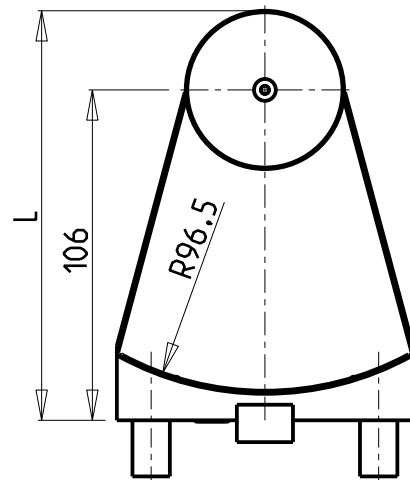
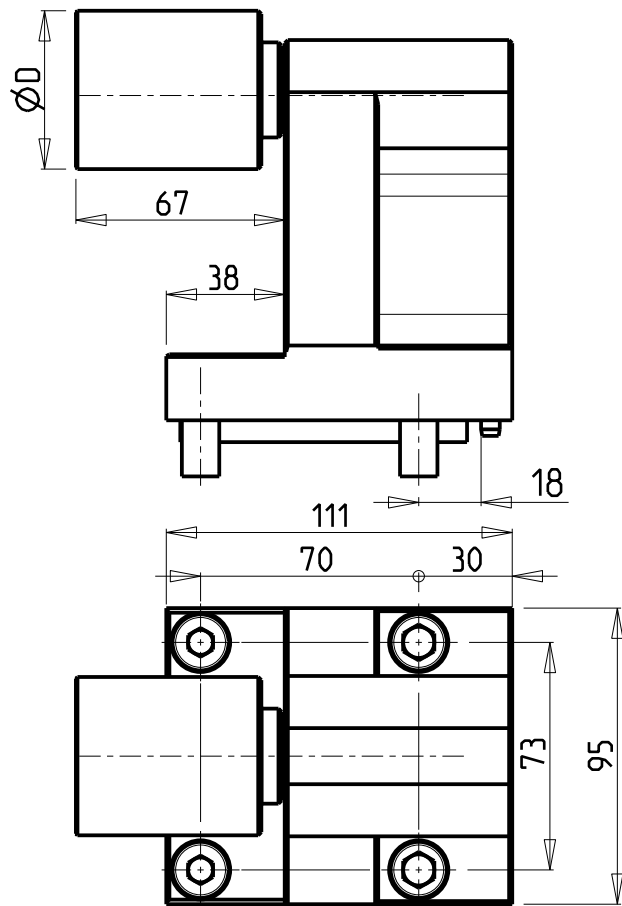

Cod. MT	N°Utensili N° Tools N° Werkzeuge	D	L
0820200	1	38	125
0820200L	1	2"	131.4

SPINNER

MOD: TC800 SMCY (BMT65)

CONTROPUNTA PER CONTROMANDRINO

Tailstock for subspindle

Gegenspitz fuer Gegenspindel

Subject to change without notice.

**M.T. srl**

Via Casino Albini 480  
Tel. 0541/956034-957884

Fax 0541/956341

47842 S. GIOVANNI IN M. (RN)  
e-mail: mtma@mtmarchetti.com  
http://www.mtmarchetti.com

PRODUZIONE MODULI ROTANTI



PAGINA SPN950-2-00

10/2018

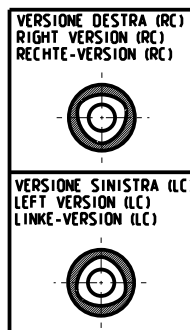
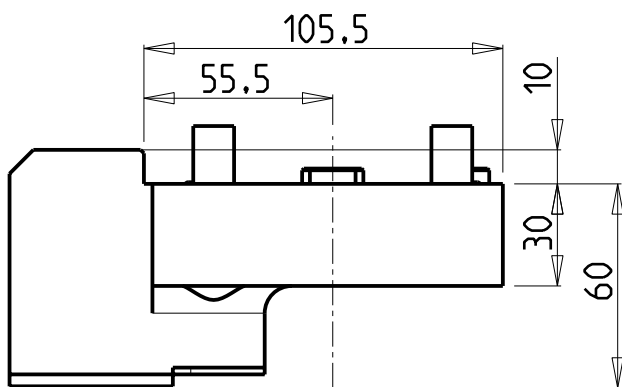
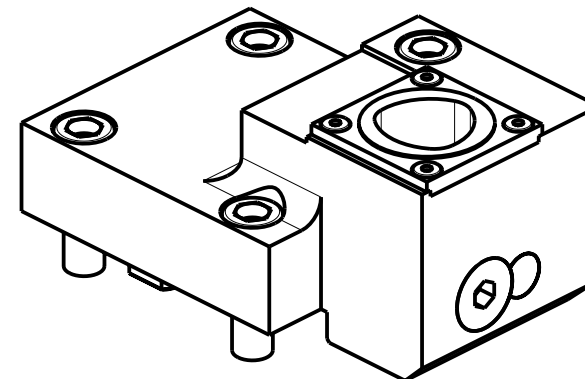
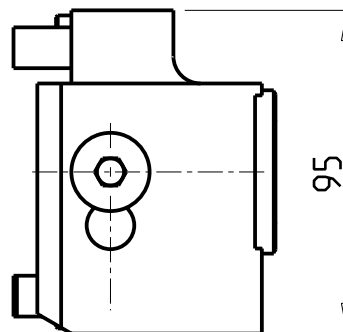
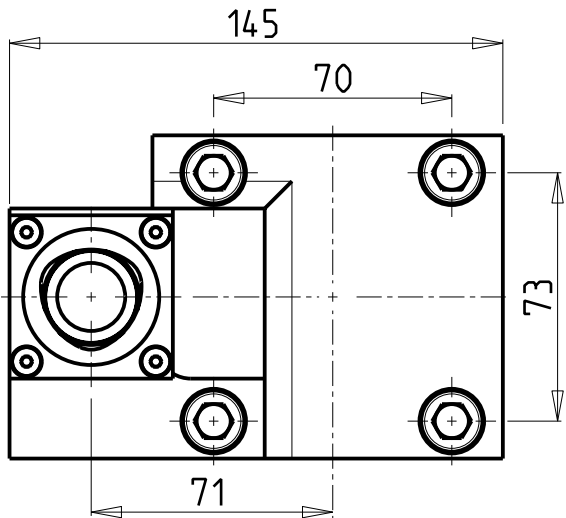

**PER ORDINARE LA VERSIONE SX  
AGGIUNGERE "LC" AL CODICE IN TABELLA.  
ES: DW01384010 DIVENTA DW01384010LC**

**TO ORDER LEFT VERSION  
ADD A "LC" IN THE CODE-CHARTS.  
EXAMPLE: DW01384010 BECOMES DW01384010LC**

**UM DIE LINKE-VERSION ZU BESTELLEN, BEI DER  
ARTIKELBEZEICHNUNG "LC" HINZUFUEGEN.  
BEISPIEL: DW01384010 WIRD DAMN DW01384010LC**

Cod. MT	N°Utensili N°Tools N°Werkzeuge	Lubrificazione int. Coolant through Innenkuehlung	Reversibile lato mandrino/contromandrino Reversible sub/main spindle side Umkehrbare Spindelseite/ Gegenspindelseite	TAGLIA Size Masse
DW01384010	1	X	X	C4

**SPINNER**

**MOD: TC800 SMCY (BMT65)**

**PORTAUTENSILE RADIALE SINGOLO ARRETRATO MT CAPTO**

**Single rear-set radial static tool MT CAPTO**

**Radial Single-Werkzeughalter zurueckversetzt MT CAPTO**

Subject to change without notice.

**M.T. srl**

Via Casino Albini 480  
Tel. 0541/956034-957884  
Fax 0541/956341  
47842 S. GIOVANNI IN M. (RN)  
e-mail: mtma@mtmarchetti.com  
http://www.mtmarchetti.com

PRODUZIONE MODULI ROTANTI



PAGINA SPN430-B-40

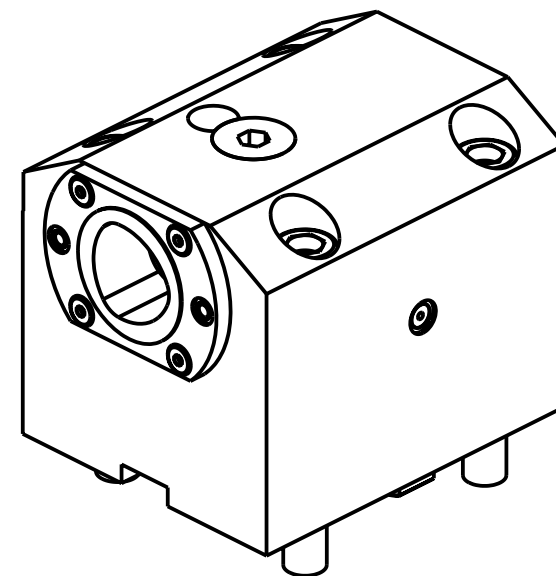
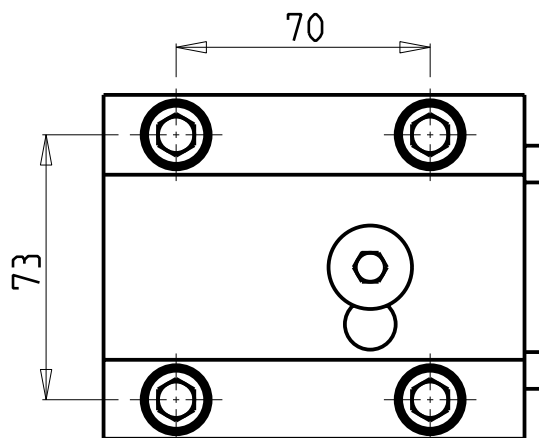
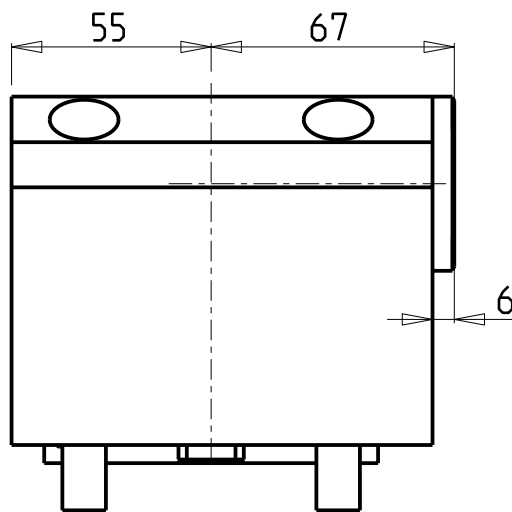
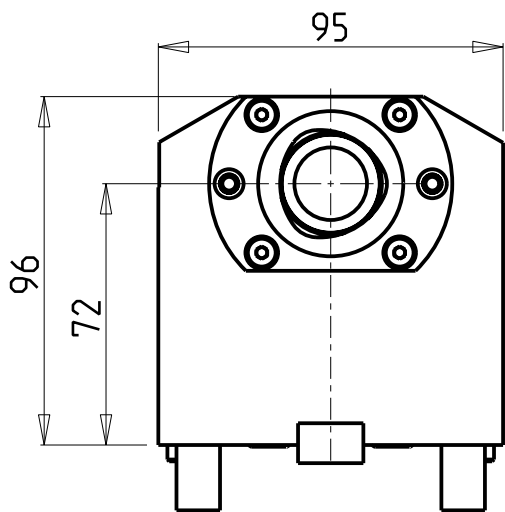

VERSIONE DESTRA (RC)  
RIGHT VERSION (RC)  
RECHTE-VERSION (RC)



VERSIONE SINISTRA (LC)  
LEFT VERSION (LC)  
LINKE-VERSION (LC)



**PER ORDINARE LA VERSIONE SX  
AGGIUNGERE "LC" AL CODICE IN TABELLA.  
ES: DW02644010 DIVENTA DW02644010LC**

**TO ORDER LEFT VERSION  
ADD A "LC" IN THE CODE-CHARTS.  
EXAMPLE: DW02644010 BECOMES DW02644010LC**

**UM DIE LINKE-VERSION ZU BESTELLEN, BEI DER  
ARTIKELBEZEICHNUNG "LC" HINZUFUEGEN.  
BEISPIEL: DW02644010 WIRD DANN DW02644010LC**

Cod. MT	N°Utensili N°Tools N°Werkzeuge	Lubrificazione int. Coolant through Innenkuehlung	Reversibile lato mandrino/contromandrino Reversible sub/main spindle side Umkehrbare Spindelseite/ Gegenspindelseite	TAGLIA Size Masse	
DW02644010	1	X	X	C4	NEW

**SPINNER**

**MOD: TC800 SMCY (BMT65)**

**PORTAUTENSILE ASSIALE SINGOLO MT CAPTO**

**Axial single static tool MT CAPTO**

**Axial Single-Werkzeughalter MT CAPTO**

Subject to change without notice.

**M.T. srl**

Via Casino Albini 480  
Tel. 0541/956034-957884  
Fax 0541/956341  
47842 S. GIOVANNI IN M. (RN)  
e-mail: mtma@mtmarchetti.com  
http://www.mtmarchetti.com

PRODUZIONE MODULI ROTANTI



PAGINA SPN550-B-40

