

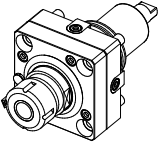

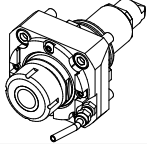

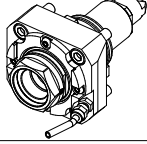
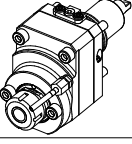
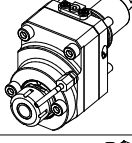
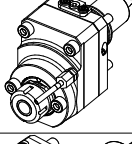
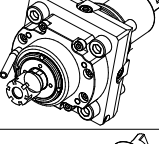
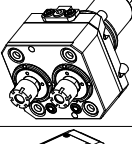
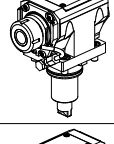
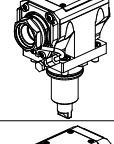
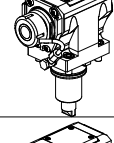
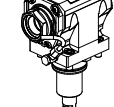
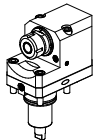

		PAGINA Page Seite
MODULO MOTORIZZATO RADIALE Radial driven tool Radial angetriebenes Werkzeug		SMG010.5.00
MODULO MOTORIZZATO RADIALE Radial driven tool Radial angetriebenes Werkzeug		SMG010.5.01
MODULO MOTORIZZATO RADIALE MTSK Radial MTSK driven tool Radial MTSK angetriebenes Werkzeug		SMG010.5.01.K
MODULO MOTORIZZATO RADIALE DISASSATO IN Z 36mm Radial driven tool re-directed in Z by 36mm Radial angetriebenes Werkzeug achsversetzt in Z um 36mm		SMG030.5.10
MODULO MOTORIZZATO RADIALE RIDOTTO I=2:1 DISASSATO IN Z 36mm Radial geared-down I=2:1 driven tool re-directed in Z by 36mm Radial angetriebenes Werkzeug untersetzt I=2:1 achsversetzt in Z um 36mm		SMG030.5.20
MODULO MOTORIZZ. RADIALE MOLTIPLICATO I=1:2 DISASSATO IN Z 36mm Radial geared-up I=1:2 driven tool re-directed in Z by 36mm Radial angetriebenes Werkzeug uebersetzt I=1:2 achsversetzt in Z um 36mm		SMG030.5.30
MODULO MOTORIZ. RADIALE MOLTIPLICATO I=1:5,625 Radial geared-up I=1:5,625 driven tool Radial angetriebenes Werkzeug uebersetzt I=1:5,625		SMG060.5.00
MODULO MOTORIZZATO RADIALE 2 USCITE IN Y Radial single side twin head driven tool in Y Radial angetriebenes Werkzeug 2 Ausgaenge in Y		SMG080.5.00
MODULO MOTORIZZATO ASSIALE H=60mm Axial driven tool H=60mm Axial angetriebenes Werkzeug H=60mm		SMG150.5.11
MODULO MOTORIZZATO ASSIALE MTSK H=60mm Axial MTSK driven tool H=60mm Axial MTSK angetriebenes Werkzeug H=60mm		SMG150.5.11.K
MODULO MOTORIZZATO ASSIALE H=70mm Axial driven tool H=70mm Axial angetriebenes Werkzeug H=70mm		SMG150.5.21
MODULO MOTORIZZATO ASSIALE MTSK H=70mm Axial MTSK driven tool H=70mm Axial MTSK angetriebenes Werkzeug H=70mm		SMG150.5.21.K

		PAGINA Page Seite
MODULO MOTORIZZATO ASSIALE ARRETRATO Axial rear-set driven tool Axial angetriebenes Werkzeug zurueckversetzt		SMG180.5.10
MODULO MOTORIZZATO ASSIALE MOLTIPLICATO I=1:2 H=60mm Axial geared-up I=1:2 driven tool H=60mm Axial angetriebenes Werkzeug uebersetzt I=1:2 H=60mm		SMG200.5.10
MODULO MOTORIZZATO ASSIALE MOLTIPLICATO I=1:2 H=70mm Axial geared-up I=1:2 driven tool H=70mm Axial angetriebenes Werkzeug uebersetzt I=1:2 H=70mm		SMG200.5.20
MODULO MOTORIZZATO ASSIALE MOLTIPLICATO I=1:5,625 H=60mm Axial geared-up I=1:5,625 driven tool H=60mm Axial angetriebenes Werkzeug uebersetzt I=1:5,625 H=60mm		SMG210.5.10
MODULO MOTORIZZATO ASSIALE MOLTIPLICATO I=1:5,625 H=70mm Axial geared-up I=1:5,625 driven tool H=70mm Axial angetriebenes Werkzeug uebersetzt I=1:5,625 H=70mm		SMG210.5.20
MODULO MOTORIZZATO ASSIALE PER POLIGONATURA INTERNA H=60mm Axial driven tool for internal polygon-making H=60mm Axial angetriebenes Werkzeug fuer interne Facettierung H=60mm		SMG230.5.10
MODULO MOTORIZZATO ASSIALE PER POLIGONATURA INTERNA H=70mm Axial driven tool for internal polygon-making H=70mm Axial angetriebenes Werkzeug fuer interne Facettierung H=70mm		SMG230.5.20
MODULO MOTORIZZATO ASSIALE BISPORGENTE H=60mm Axial opposite face twin driven tool H=60mm Axial angetriebenes Werkzeug halb vorspringend H=60mm		SMG240.5.10
MODULO MOTORIZZATO ASSIALE BISPORGENTE H=60mm Axial opposite face twin driven tool H=60mm Axial angetriebenes Werkzeug halb vorspringend H=60mm		SMG240.5.11
MODULO MOTORIZZATO ASSIALE BISPORGENTE H=70mm Axial opposite face twin driven tool H=70mm Axial angetriebenes Werkzeug halb vorspringend H=70mm		SMG240.5.20
MODULO MOTORIZZATO ASSIALE BISPORGENTE H=70mm Axial opposite face twin driven tool H=70mm Axial angetriebenes Werkzeug halb vorspringend H=70mm		SMG240.5.21
MODULO MOTORIZZATO ASSIALE ARRETRATO BISPORGENTE Axial opposite face rear-set driven tool Axial angetriebenes Werkzeug zurueckversetzt halb vorspringend		SMG243.5.10

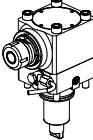
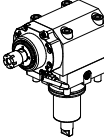
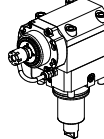
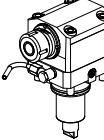
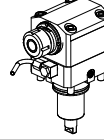
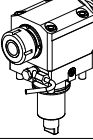
		PAGINA Page Seite
MODULO MOTORIZZATO ASSIALE 2 USCITE IN Y H=60mm Axial single side twin head driven tool in Y H=60mm Axial angetriebenes Werkzeug 2 Ausgaenge in Y H=60mm		SMG260.5.10
MODULO MOTORIZZATO ASSIALE 2 USCITE IN Y H=70mm Axial single side twin head driven tool in Y H=70mm Axial angetriebenes Werkzeug 2 Ausgaenge in Y H=70mm		SMG260.5.20
MODULO MOTORIZZ. ASSIALE 2 USCITE IN Y MOLTIPLICATO l=1:2 H=60mm Axial geared-up l=1:2 single side twin head driven tool in Y H=60mm Axial angetriebenes Werkzeug 2 Ausgaenge in Y uebersetzt l=1:2 H=60mm		SMG261.5.10
MODULO MOTORIZZ. ASSIALE 2 USCITE IN Y MOLTIPLICATO l=1:2 H=70mm Axial geared-up l=1:2 single side twin head driven tool in Y H=70mm Axial angetriebenes Werkzeug 2 Ausgaenge in Y uebersetzt l=1:2 H=70mm		SMG261.5.20
MODULO MOTORIZZATO ASSIALE 2+2 USCITE IN Y H=60mm Axial multiple 2+2 outlet driven tool in Y H=60mm Axial angetriebenes Mehrspindel-Werkzeug 2+2 Ausgaenge in Y H=60mm		SMG268.5.10
MODULO MOTORIZZATO ASSIALE 2+2 USCITE IN Y H=70mm Axial multiple 2+2 outlet driven tool in Y H=70mm Axial angetriebenes Mehrspindel-Werkzeug 2+2 Ausgaenge in Y H=70mm		SMG268.5.20
MODULO MOTORIZZATO ORIENTABILE ±90° H=54mm ±90° adjustable angle driven tool H=54mm Angetriebenes Werkzeug schwenkbar ±90° H=54mm		SMG333.5.00
MODULO MOTORIZZ. ORIENTABILE ±90° CON NONIO DIGITALE H=54mm ±90° adjustable angle driven tool with digital display H=54mm Angetriebenes Werkzeug schwenkbar ±90° mit digital display H=54mm		SMG333.5.01
MODULO MOTORIZZATO ORIENTABILE ±90° H=47,5mm ±90° adjustable angle driven tool H=47,5mm Angetriebenes Werkzeug schwenkbar ±90° H=47,5mm		SMG335.5.00
MODULO MOTORIZZ. ORIENTABILE ±90° CON NONIO DIGITALE H=47,5mm ±90° adjustable angle driven tool with digital display H=47,5mm Angetriebenes Werkzeug schwenkbar ±90° mit digital display H=47,5mm		SMG335.5.01
MODULO MOTORIZZATO ORIENTABILE ±90° MOLTIPLICATO l=1:2 H=47,5mm ±90° adjustable angle driven tool geared-up l=1:2 H=47,5mm Angetriebenes Werkzeug schwenkbar ±90° uebersetzt l=1:2 H=47,5mm		SMG336.5.00
MOD. MOT. ORIENTAB. ±90° MOLTIPL. l=1:2 CON NONIO DIGITALE H=47,5mm ±90° adjustable angle driven tool geared-up l=1:2 with digital display H=47,5mm Angetr. Werkzeug schwenkbar ±90° uebersetzt l=1:2 mit digital display H=47,5mm		SMG336.5.01

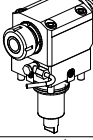
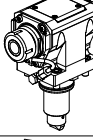
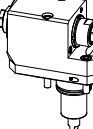
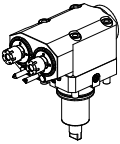
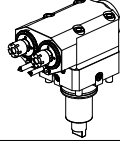
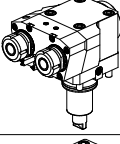
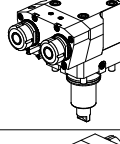
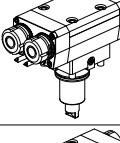
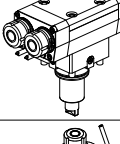
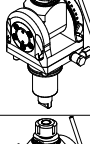
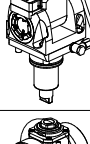
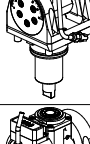
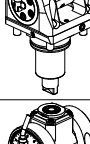
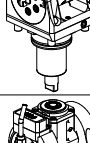
		PAGINA Page Seite
MODULO MOTORIZZATO PORTACREATORE Driven gear hobber Angetriebenes Zahnradwaelzfraes-Werkzeug		SMG340.5.00
MODULO MOTORIZZATO PORTACREATORE RADIALE Radial driven gear hobber Radial Angetriebenes Zahnradwaelzfraes-Werkzeug		SMG340.5.30
PORTAUTENSILE RADIALE SINGOLO QD=25mm / QD=1" Radial single static tool QD=25mm / QD=1" Radial Single-Werkzeughalter QD=25mm / QD=1"		SMG423.5.00
PORTAUTENSILE RADIALE SOVRAPPOSTO QD=25mm / QD=1" Radial single side twin static tool QD=25mm / QD=1" Radial Werkzeughalter ueberlagert QD=25mm / QD=1"		SMG442.5.00
PORTAUT. RADIALE DOPPIO SOVRAP. QD=20mm / QD=3/4" / QD=25mm / QD=1" Radial double side twin static tool QD=20mm / QD=3/4" / QD=25mm / QD=1" Radial Doppel-Werkzeughalter ueberlagert QD=20mm / QD=3/4" / QD=25mm / QD=1"		SMG463.5.00
PORTAUTENSILE RADIALE PER LAMA Radial blade holder Radial Abstechhalter		SMG520.5.01
PORTAUTENSILE RADIALE PER LAMA CON LUBRIFICAZIONE INTERNA Radial blade holder with internal coolant Radial Abstechhalter mit Innenkuehlung		SMG520.5.05
PORTAUTENSILE ASSIALE SINGOLO QD=25mm / QD=1" Axial single static tool QD=25mm / QD=1" Axial Single-Werkzeughalter QD=25mm / QD=1"		SMG552.5.00
PORTAUTENSILE ASSIALE PER BARENO Ø50mm / Ø2" H=75mm Axial single boring bar holder Ø50mm / Ø2" H=75mm Axial Bohrhalter Ø50mm / Ø2" H=75mm		SMG610.5.10
PORTAUTENSILE ASSIALE PER BARENO Ø40mm / Ø1 1/2" H=60mm Axial single boring bar holder Ø40mm / Ø1 1/2" H=60mm Axial Bohrhalter Ø40mm / Ø1 1/2" H=60mm		SMG630.5.20
PORTAUTENSILE RADIALE SINGOLO ARRETRATO MT CAPTO Radial single rear-set static tool MT CAPTO Radial Single-Werkzeughalter zurueckversetzt MT CAPTO		SMG430.E.40
PORTAUTENSILE ASSIALE SINGOLO ARRETRATO MT CAPTO Axial single rear-set static tool MT CAPTO Axial Single-Werkzeughalter zurueckversetzt MT CAPTO		SMG555.E.40

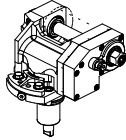
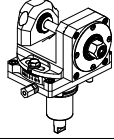
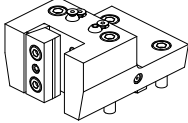
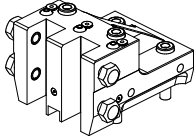
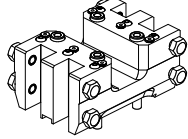
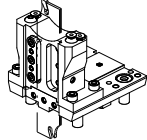
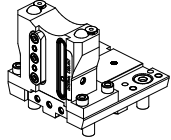
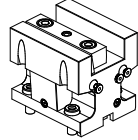
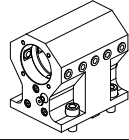
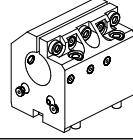
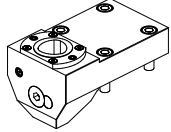
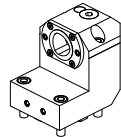
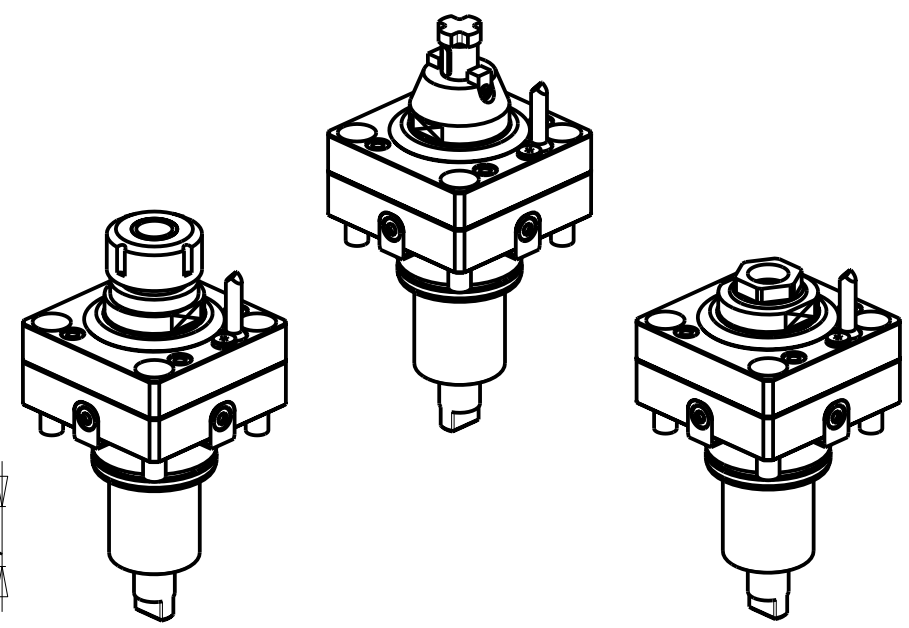
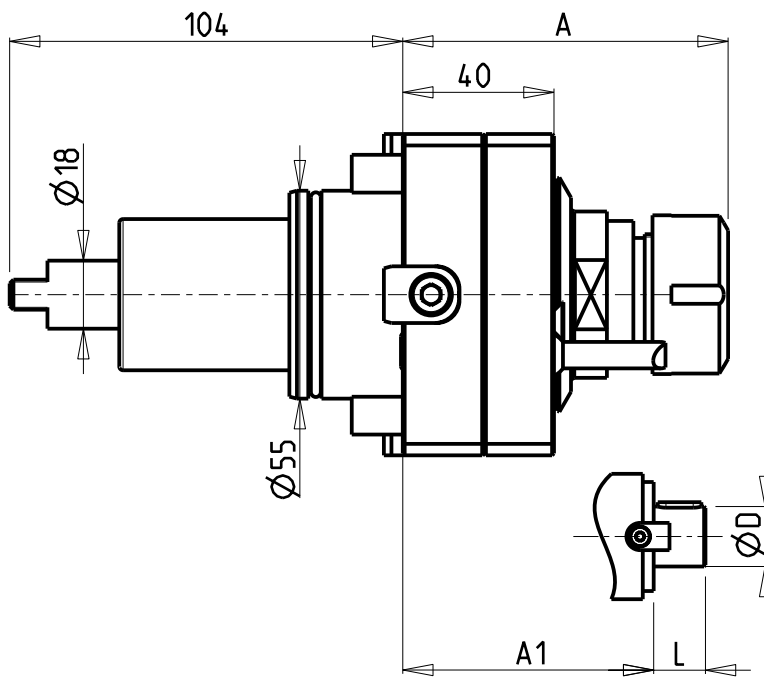
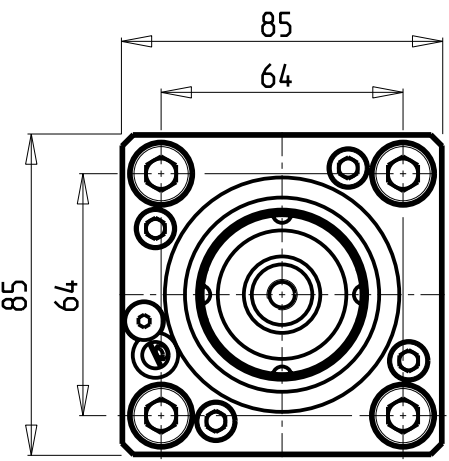

ATTENZIONE - ATTENTION - ACHTUNG

- FINO AD ESAURIMENTO SCORTE
- clearance sale
- solange vorrat

- Chiave inclusa
- Key included
- Schlüssel inbegriffen

Cod. MT	Cod. EPPINGER	Mandrino Spindle Spindel	I	RPM	Coppia Max Max Torque Max Drehmoment	Lubrificazione int. Coolant through Innenkuehlung	Lubrificazione est. Ext. coolant Aussenkuehlung	A	A1	D	L	CHIAVI NON INCLUSE Keys not included Schlüssel nicht einbegriffen	
0271325	-	ER25	1:1	6000	50Nm	-	X	86.06	-	-	-	CHSTER25	CHUB40 o 0270018
0271525	7.070.679	ER A 25	1:1	6000	50Nm	-	X	63.03	-	-	-	CHUB27	CHUB40 o 0270018
0271025	-	ER A 25	1:1	6000	50Nm	P=30bar	X	63.03	-	-	-	CHUB27	CHUB40 o 0270018
0271617	-	Ø16x17	1:1	6000	50Nm	-	X	-	70	16	17	CH_VTCROCE_M08	CHUB40 o 0270018
0272219	-	Ø22x19	1:1	6000	50Nm	-	X	-	70	22	19	CH_VTCROCE_M10	CHUB40 o 0270018

SAMSUNG
 MOD: PL240 LM - PL250 VM - SL1500/2000 M/Y/SY

MODULO MOTORIZZATO RADIALE
 Radial driven tool
 Radial angetriebenes Werkzeug

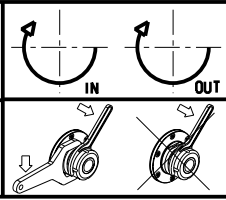

M.T. srl
 Via Casino Albini 480
 Tel. 0541/956034-957884
 Fax 0541/956341
 47842 S. GIOVANNI IN M. (RN)
 e-mail: mtma@mtmarchetti.com
 http://www.mtmarchetti.com

PRODUZIONE MODULI ROTANTI

 PAGINA SMG010-5-00

Subject to change without notice.

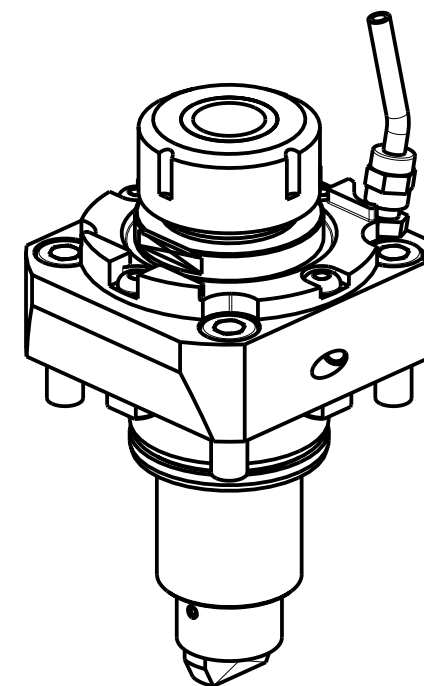
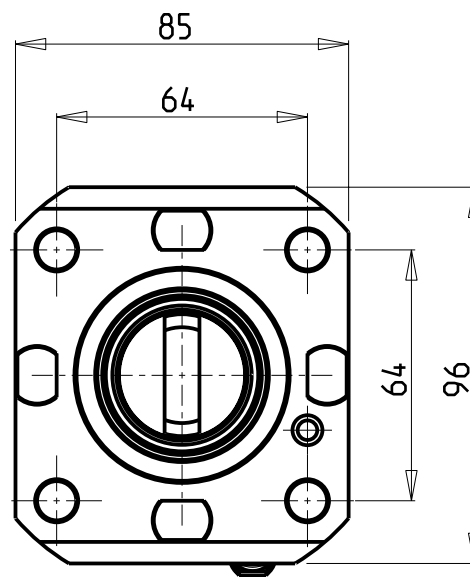
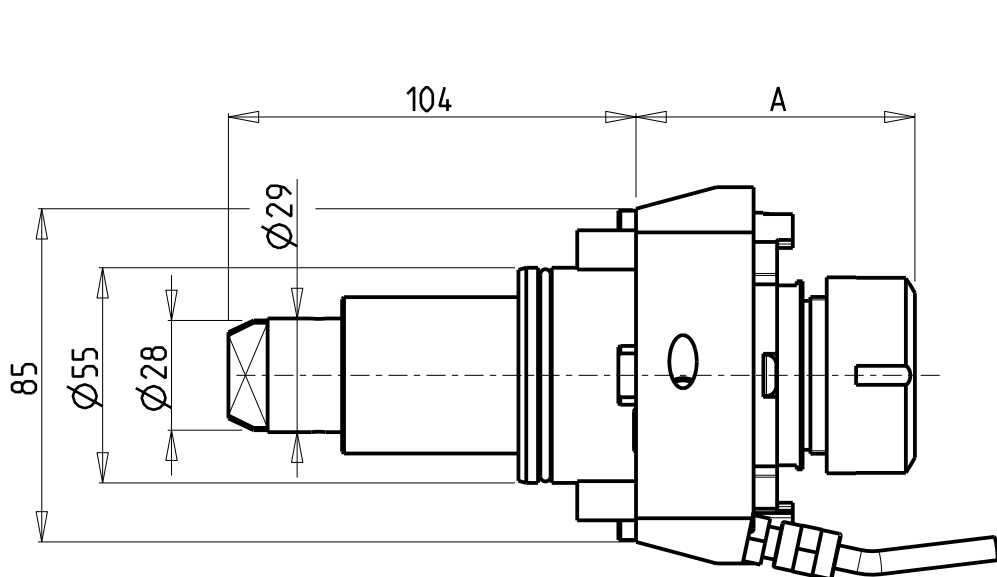

Cod. MT	Mandrino Spindle Spindel	I	RPM	Coppia Max Max Torque Max Drehmoment	Lubrificazione int. Coolant through Innenkuehlung	Lubrificazione est. Ext. coolant Aussenkuehlung	A	CHIAVI NON INCLUDE Keys not included Schluessel nicht einbegriffen		
								CHUB27	CHTAER25ZC	OKU0650004
DW 00901325	ERA25	1:1	6000	50Nm	-	X	42.5	CHUB27	CHTAER25ZC	OKU0650004
DW 00901425	ERA25	1:1	6000	50Nm	P=30bar	X	54.5	CHUB27	CHTAER25ZC	OKU0650004
DW 00901132	ER32	1:1	6000	50Nm	-	X	71.2	CHSTER32	-	OKU0650004
DW 00901232	ER32	1:1	6000	50Nm	P=30bar	X	79.2	CHSTER32	-	OKU0650004
DW 00900332	ERA32	1:1	6000	50Nm	-	X	54.5	CHUB30	CHTAER32ZC	OKU0650004
DW 00901432	ERA32	1:1	6000	50Nm	P=30bar	X	62.5	CHUB30	CHTAER32ZC	OKU0650004

- Chiave inclusa
- Key included
- Schluessel inbegriffen

SAMSUNG
 MOD: PL240 LM - PL250 VM - SL1500/2000 M/Y/SY

MODULO MOTORIZZATO RADIALE
 Radial driven tool
 Radial angetriebenes Werkzeug

Subject to change without notice.

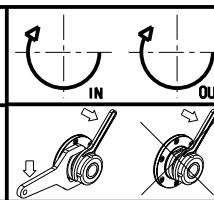

M.T. srl
 Via Casino Albini 480
 Tel. 0541/956034-957884
 Fax 0541/956341
 47842 S. GIOVANNI IN M. (RN)
 e-mail: mtma@mtmarchetti.com
 http://www.mtmarchetti.com

PRODUZIONE MODULI ROTANTI



PAGINA SMG010-5-01

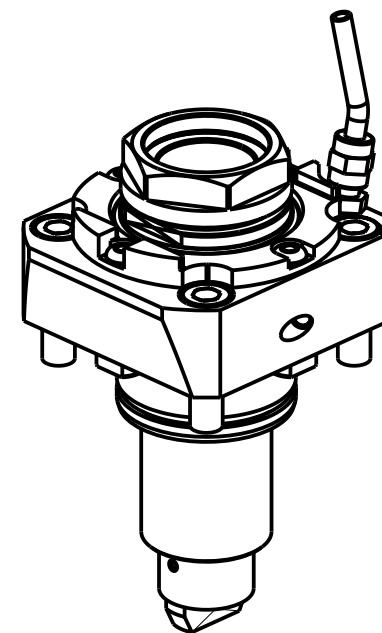
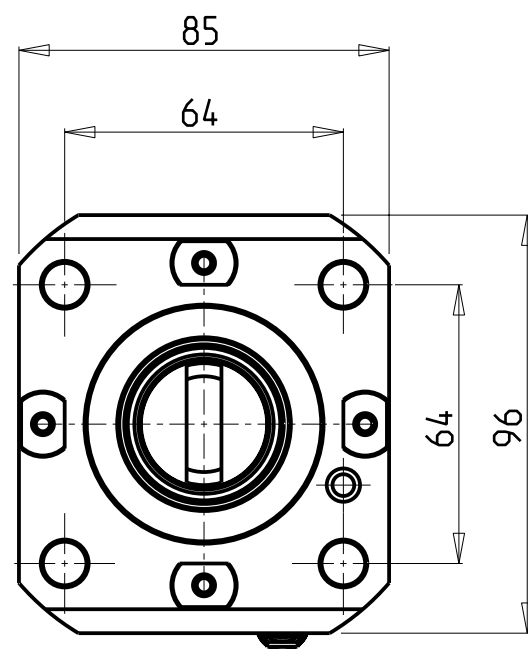
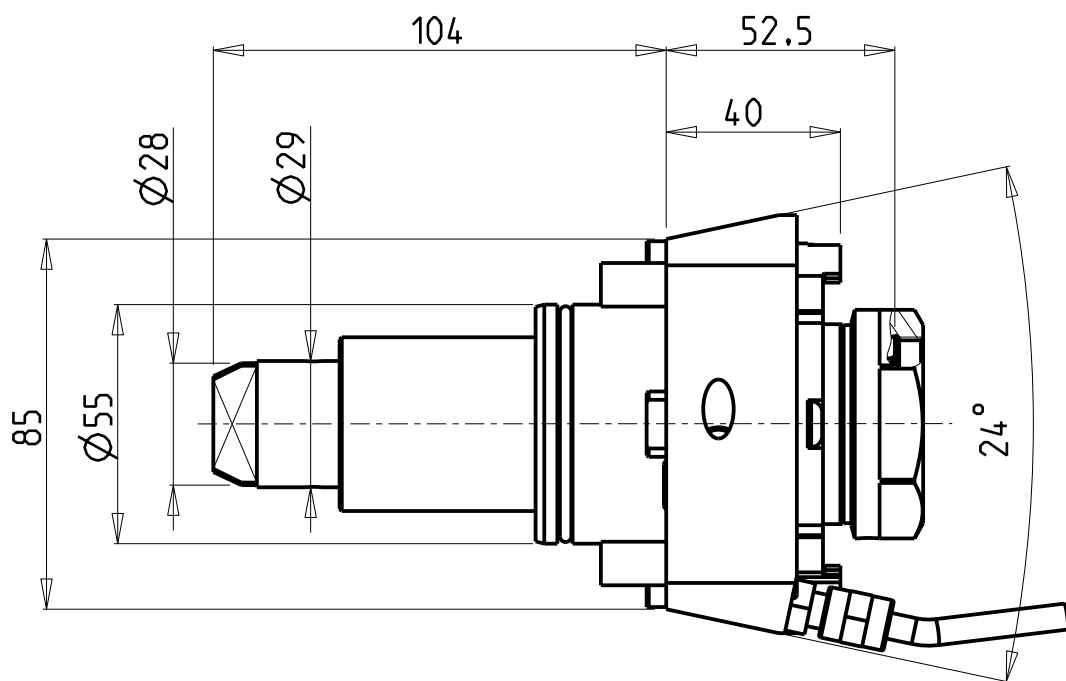

PER PORTAUTENSILI MODULARI MTSK-40 VEDI PAG. TBL300-1-40
 FOR MTSK-40 QUICK CHANGE TOOLHOLDERS CLAMPINGS SEE PAGE TBL300-1-40
 FUER MTSK-40 MODULARE WERKZEUGAUFNAHMEN SIEHE SEITE TBL300-1-40

- Chiave inclusa
- Key included
- Schluessel inbegriffen

Cod. MT	Mandrino Spindle Spindel	I	RPM	Coppia Max Max Torque Max Drehmoment	Lubrificazione est. Ext. coolant Aussekkuehlung	Lubrificazione int. Coolant through Innenkuehlung	CHIAVI NON INCLUSE Keys not included Schluessel nicht einbegriffen	
DW00801140	MTSK-40	1:1	6000	50Nm	X	-	CHUB46	OKU0650004 *
DW00800240	MTSK-40	1:1	6000	50Nm	X	P=30bar	CHUB46	OKU0650004 *

SAMSUNG
 MOD: PL240 LM - PL250 VM - SL1500/2000 M/Y/SY

MODULO MOTORIZZATO RADIALE MTSK
 Radial MTSK driven tool
 Radial MTSK angetriebenes Werkzeug

Subject to change without notice.

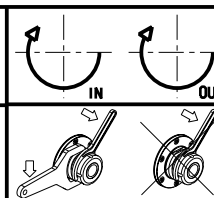

M.T. srl
 Via Casino Albini 480
 Tel. 0541/956034-957884
 Fax 0541/956341
 47842 S. GIOVANNI IN M. (RN)
 e-mail: mtma@mtmarchetti.com
 http://www.mtmarchetti.com

PRODUZIONE MODULI ROTANTI



PAGINA SMG010-5-01-K

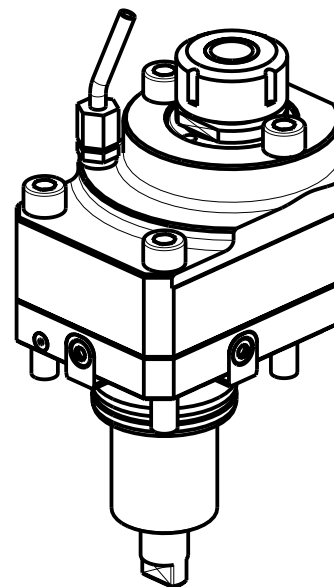
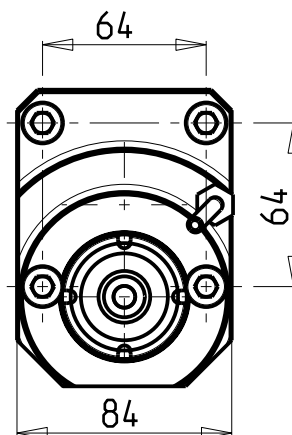
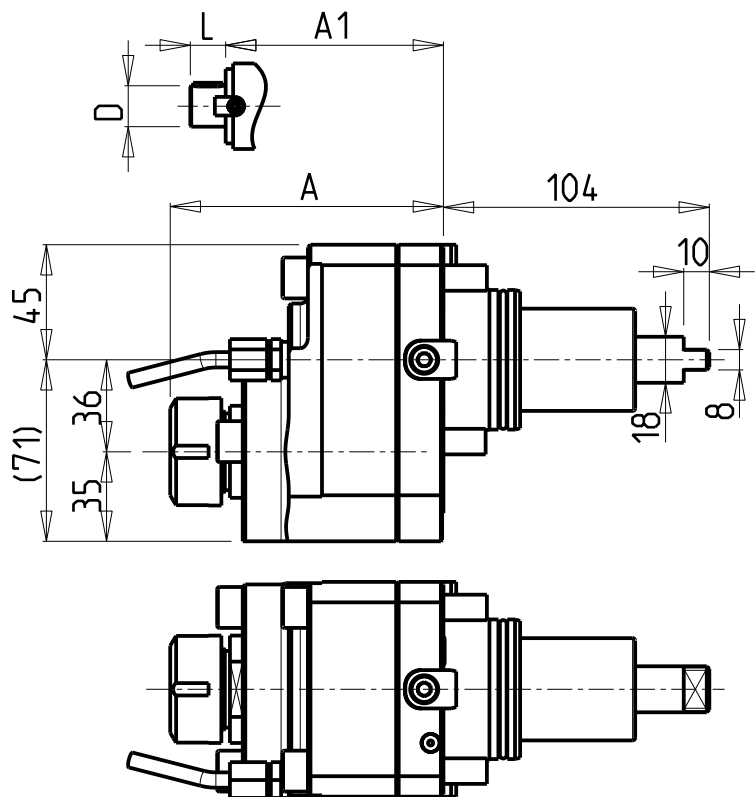

ATTENZIONE - ATTENTION - ACHTUNG

- VERIFICARE LE MISURE DI INGOMBRO PER POSSIBILE INTERFERENZA SU ALCUNI MODELLI DI MACCHINE
- Please check the overall sizes for possible interferences on some machine models
- Bitte überprüfen sie das ausmass um mögliche interferenzen auf einigen maschinen modellen zu vermeiden

- Chiave inclusa
- Key included
- Schlüssel inbegriffen

Cod. MT	Mandrino Spindle Spindel	I	RPM	Coppia Max Max Torque Max Drehmoment	Reversibile lato mandrino/contromandrino Reversible sub/main spindle side Umkehrbare Spindelseite/ Gegenspindelseite	Lubrificazione est. Ext. coolant Aussenkuehlung	A	A1	D	L	CHIAVI NON INCLUSE Keys not included Schlüssel nicht einbegriffen	
0720025	ER25	1:1	6000	50Nm	X	X	106.86	-	-	-	CHSTER25	MNLO210007
0720032	ER32	1:1	6000	50Nm	X	X	120.56	-	-	-	CHSTER32	MNLO210007
0720016	Ø16x17	1:1	6000	50Nm	X	X	-	88.5	16	17	CH_VTCROCE_M08	MNLO210007
0720022	Ø22x19	1:1	6000	50Nm	X	X	-	90.5	22	19	CH_VTCROCE_M10	MNLO210007
0720027	Ø27x21	1:1	6000	50Nm	X	X	-	92.5	27	21	CH_VTCROCE_M12	MNLO210007

SAMSUNG

MOD: PL240 LM - PL250 VM - SL1500/2000 M/Y/SY

MODULO MOTORIZZATO RADIALE DISASSATO IN Z 36mm

Radial driven tool re-directed in Z by 36mm

Radial angetriebenes Werkzeug achsversetzt in Z um 36mm

Subject to change without notice.

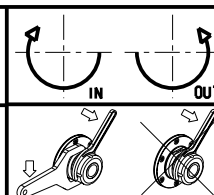

M.T. srl

Via Casino Albini 480
Tel. 0541/956034-957884
Fax 0541/956341

47842 S. GIOVANNI IN M. (RN)
e-mail: mtma@mtmarchetti.com
http://www.mtmarchetti.com

PRODUZIONE MODULI ROTANTI



PAGINA SMG030-5-10

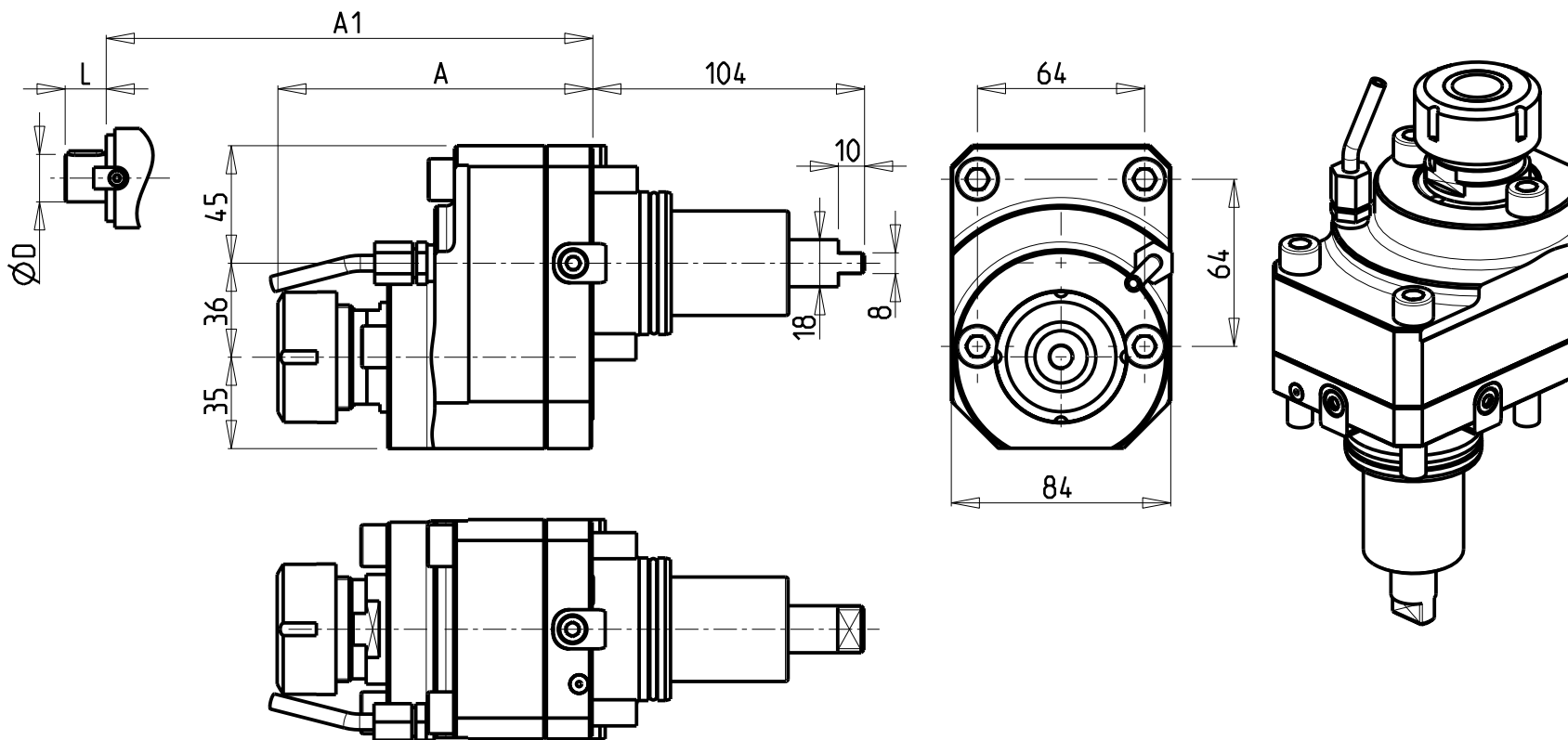

ATTENZIONE - ATTENTION - ACHTUNG

- VERIFICARE LE MISURE DI INGOMBRO PER POSSIBILE INTERFERENZA SU ALCUNI MODELLI DI MACCHINE
- Please check the overall sizes for possible interferences on some machine models
- Bitte überprüfen sie das ausmass um mögliche interferenzen auf einigen maschinen modellen zu vermeiden

- Chiave inclusa
- Key included
- Schluessel inbegriffen

Cod. MT	Mandrino Spindle Spindel	I	RPM	Coppia Max Max Torque Max Drehmoment	Reversibile lato mandrino/contromandrino Reversible sub/main spindle side Umkehrbare Spindel-seite/ Gegen-spindel-seite	Lubrificazione est. Ext. coolant Aussenkuehlung	A	A1	D	L	CHIAVI NON INCLUSE Keys not included Schluessel nicht einbegriffen	
0722132	ER32	2:1	3000	65Nm	X	X	120.56	-	-	-	CHSTER32	MNL0210007
0722116	Ø16x17	2:1	3000	65Nm	X	X	-	88.5	16	17	CH_VTCROCE_M08	MNL0210007
0722122	Ø22x19	2:1	3000	65Nm	X	X	-	90.5	22	19	CH_VTCROCE_M10	MNL0210007
0722127	Ø27x21	2:1	3000	65Nm	X	X	-	92.5	27	21	CH_VTCROCE_M12	MNL0210007

SAMSUNG

MOD: PL240 LM - PL250 VM - SL1500/2000 M/Y/SY

MODULO MOTORIZZATO RADIALE RIDOTTO I=2:1 DISASSATO IN Z 36mm

Radial geared-down I=2:1 driven tool re-directed in Z by 36mm

Radial angetriebenes Werkzeug untersetzt I=2:1 achsversetzt in Z um 36mm

Subject to change without notice.

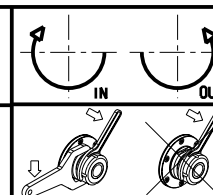

M.T. srl

Via Casino Albini 480
Tel. 0541/956034-957884
Fax 0541/956341
47842 S. GIOVANNI IN M. (RN)
e-mail: mtma@mtmarchetti.com
http://www.mtmarchetti.com

PRODUZIONE MODULI ROTANTI



PAGINA SMG030-5-20

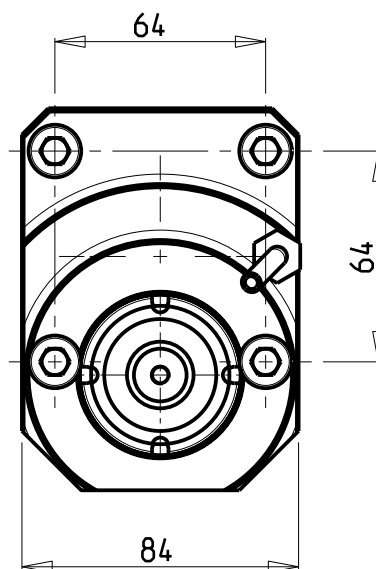
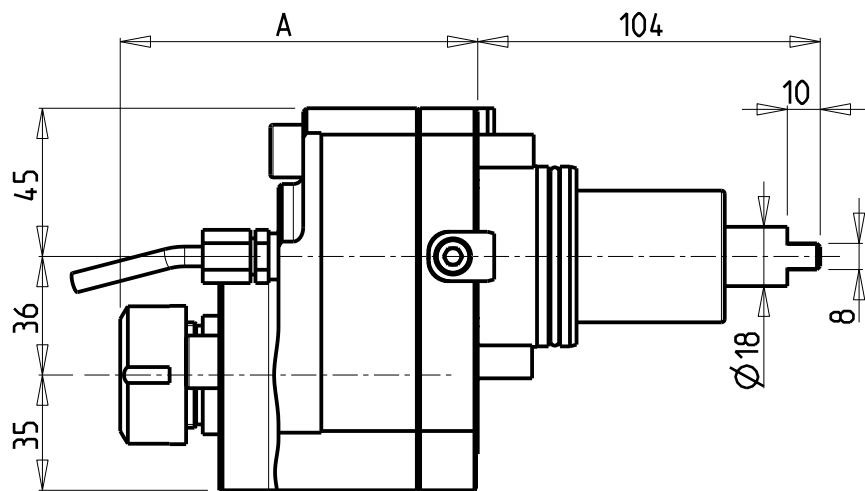

ATTENZIONE - ATTENTION - ACHTUNG

- VERIFICARE LE MISURE DI INGOMBRO PER POSSIBILE INTERFERENZA SU ALCUNI MODELLI DI MACCHINE
- Please check the overall sizes for possible interferences on some machine models
- Bitte überprüfen sie das ausmass um mögliche interferenzen auf einigen maschinen modellen zu vermeiden

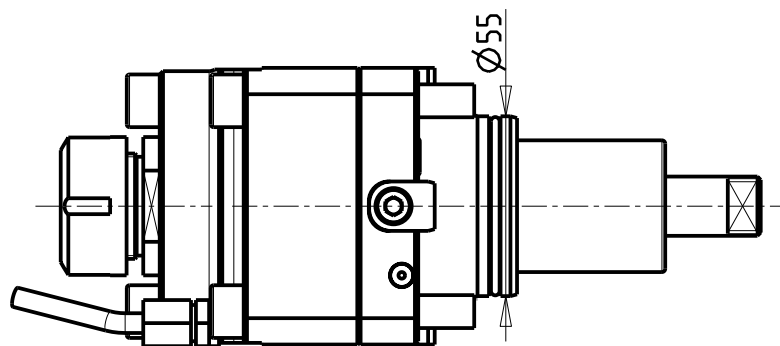
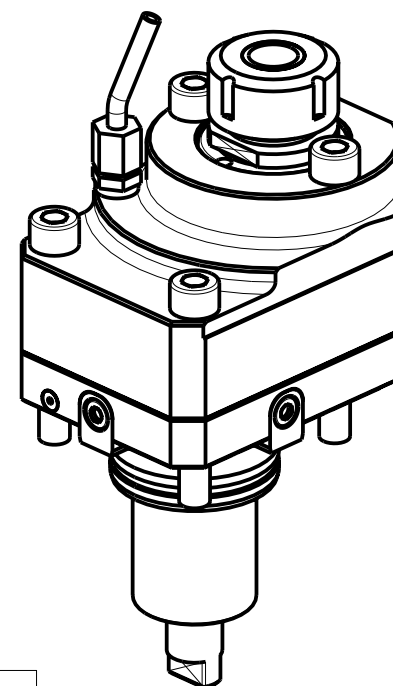

Cod. MT	Mandrino Spindle Spindel	I	RPM	Coppia Max Max Torque Max Drehmoment	Reversibile lato mandrino/contromandrino Reversible sub/main spindle side Umkehrbare Spindel-seite/ Gegenspindel-seite	Lubrificazione est. Ext. coolant Aussenkuehlung	A	CHIAVI NON INCLUSE Keys not included Schlüssel nicht einbegriffen	
0721225	ER25	1:2	12000	30Nm	X	X	108.56	CHSTER25	MNL0210007

SAMSUNG

MOD: PL240 LM - PL250 VM - SL1500/2000 M/Y/SY

MODULO MOTORIZZATO RADIALE Moltiplicato I=1:2 DISASSATO IN Z 36mm

Radial geared-up I=1:2 driven tool re-directed in Z by 36mm

Radial angetriebenes Werkzeug uebersetzt I=1:2 achsversetzt in Z um 36mm

Subject to change without notice.

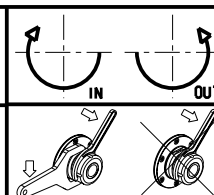

M.T. srl

Via Casino Albini 480
Tel. 0541/956034-957884
Fax 0541/956341

47842 S. GIOVANNI IN M. (RN)
e-mail: mtma@mtmarchetti.com
http://www.mtmarchetti.com

PRODUZIONE MODULI ROTANTI



PAGINA SMG030-5-30

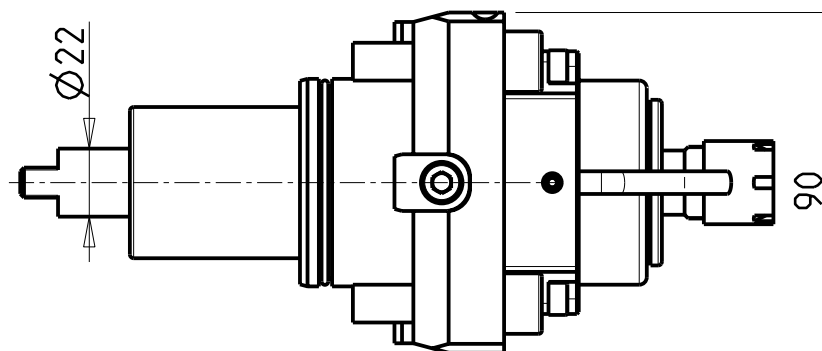
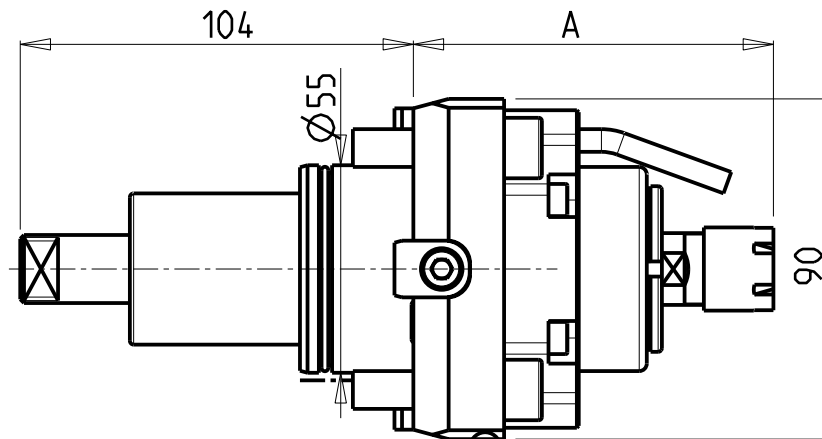
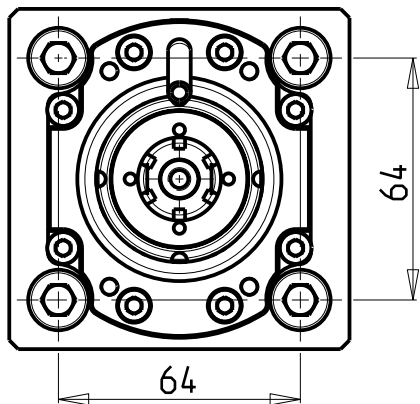

ATTENZIONE - ATTENTION - ACHTUNG

- Per lo smontaggio degli utensili utilizzare sempre la chiave di contrasto come indicato nel manuale d'uso.
- For disassembly of the tools use always the contrast key as mentioned in the user instructions.
- Fuer das Abmontieren der Werkzeuge immer den Gegenschlüssel benutzen wie in der Bedienungsanleitung erwaeht.

ATTENZIONE - ATTENTION - ACHTUNG

- VERIFICARE LE MISURE DI INGOMBRO PER POSSIBILE INTERFERENZA SU ALCUNI MODELLI DI MACCHINE
- Please check the overall sizes for possible interferences on some machine models
- Bitte überprüfen sie das ausmass um mögliche interferenzen auf einigen maschinen modellen zu vermeiden

ATTENZIONE - ATTENTION - ACHTUNG

- PRIMA DI UTILIZZARE IL MOTORIZZATO CONSULTARE LE ISTRUZIONI ALLEGATE!
- BEFORE USING THE DRIVEN TOOL, PLEASE CHECK THE ENCLOSED INSTRUCTION SHEET!
- VOR DER BENUTZUNG DES ANGETRIEBENEN WERKZEUGES, DIE BEILIEGENDEN INSTRUKTIONEN DURCHLESEN!

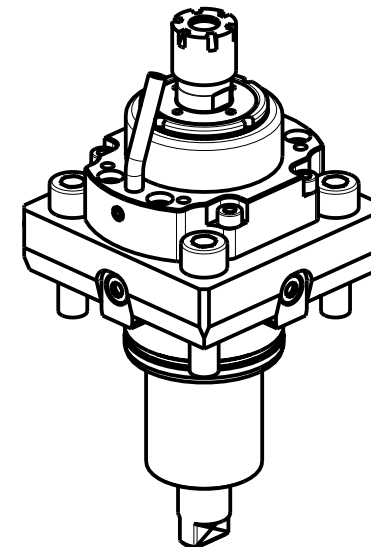

Cod. MT	Mandrino Spindle Spindel	I	RPM	Coppia Max Max Torque Max Drehmoment	Lubrificazione int. Coolant through Innenkuehlung	Lubrificazione est. Ext. coolant Ausssenkuehlung	A	CHIAVI INCLUSE Keys included Schluessel einbegriffen	
DW 00600116	ER16	1:5.625	22500	6Nm		X	95.25	CHMNER16	CHUB17
DW 00600111	ER11	1:5.625	22500	6Nm	P=30bar	X	107.45	CHMNER11	CHUB11

SAMSUNG

MOD: PL240 LM - PL250 VM - SL1500/2000 M/Y/SY

MODULO MOTORIZZATO RADIALE Moltiplicato I=1:5.625

Radial geared-up I=1:5.625 driven tool

Radial angetriebenes Werkzeug uebersetzt I=1:5.625

Subject to change without notice.

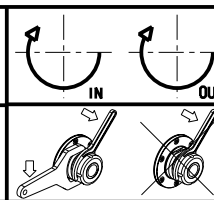

M.T. srl

Via Casino Albini 480
Tel. 0541/956034-957884
Fax 0541/956341
47842 S. GIOVANNI IN M. (RN)
e-mail: mtma@mtmarchetti.com
http://www.mtmarchetti.com

PRODUZIONE MODULI ROTANTI



PAGINA SMG060-5-00

ATTENZIONE - ATTENTION - ACHTUNG

- Per lo smontaggio degli utensili utilizzare sempre la chiave di contrasto come indicato nel manuale d'uso.
- For disassembly of the tools use always the contrast key as mentioned in the user instructions.
- Fuer das Abmontieren der Werkzeuge immer den Gegenschlüssel benutzen wie in der Bedienungsanleitung erwaeht.

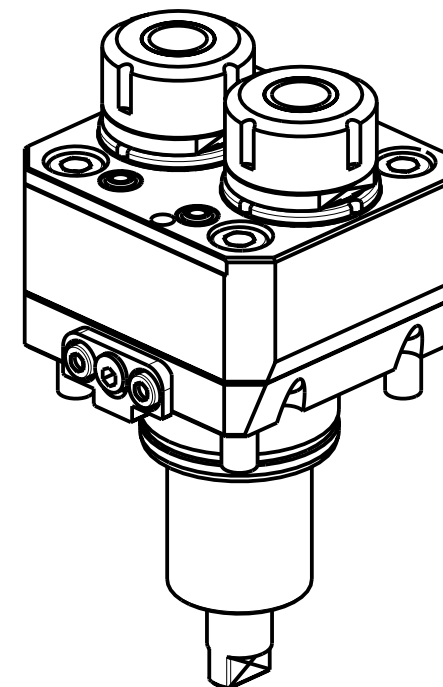
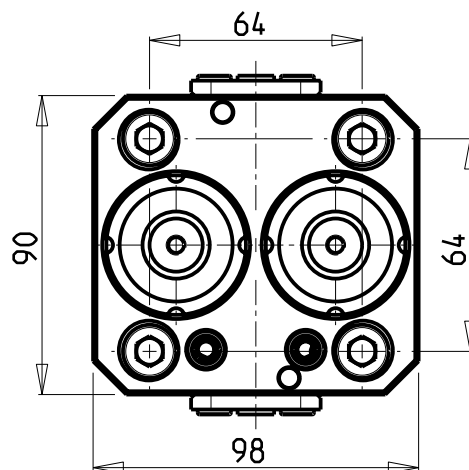
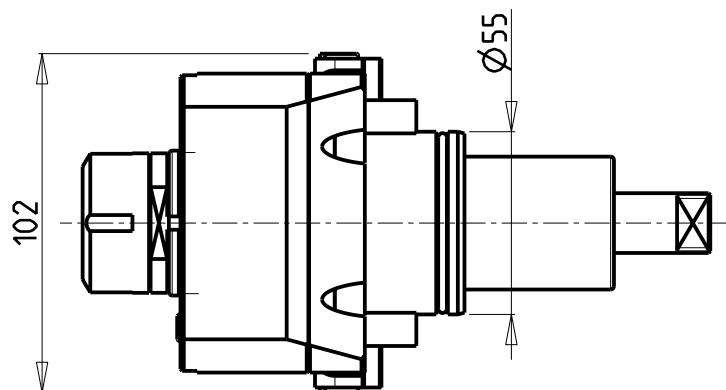
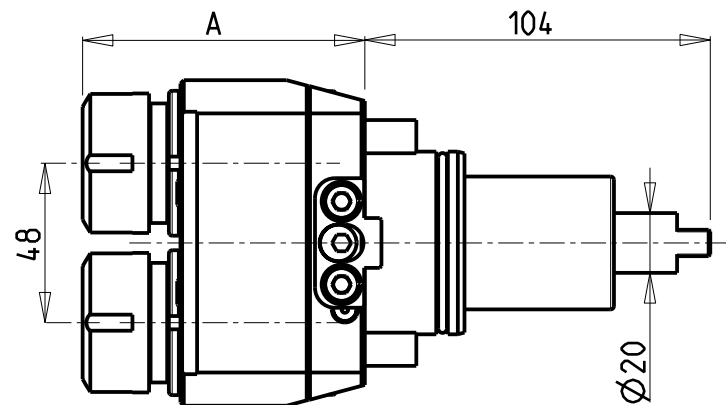

Cod. MT	Mandrino Spindle Spindel	I	RPM	Coppia Max Max Torque Max Drehmoment	Lubrificazione est. Ext. coolant Aussenkuehlung	A	CHIAVI NON INCLUSE Keys not included Schlüssel nicht einbegriffen	
0730016X2	ER16	1:1	6000	30Nm	X	84.5	CHMNER16	CHUB17
0730025X2	ER25	1:1	6000	30Nm	X	85	CHSTER25	MNLO210007

SAMSUNG
MOD: SL1500/2000 M/Y/SY

MODULO MOTORIZZATO RADIALE 2 USCITE IN Y
Radial single side twin head driven tool in Y
Radial angetriebenes Werkzeug 2 Ausgaenge in Y

Subject to change without notice.

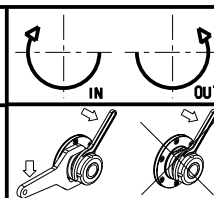

M.T. srl
Via Casino Albini 480
Tel. 0541/956034-957884
Fax 0541/956341
47842 S. GIOVANNI IN M. (RN)
e-mail: mtma@mtmarchetti.com
http://www.mtmarchetti.com

PRODUZIONE MODULI ROTANTI



PAGINA SMG080-5-00

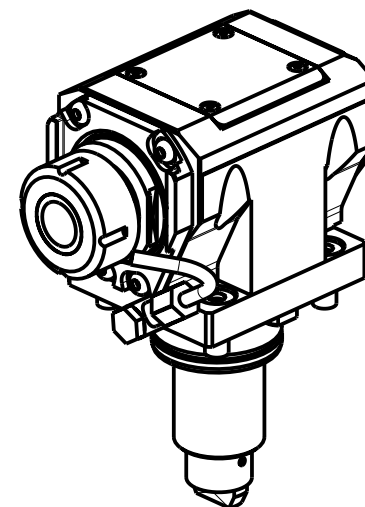
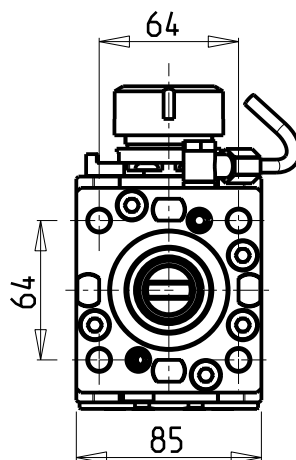
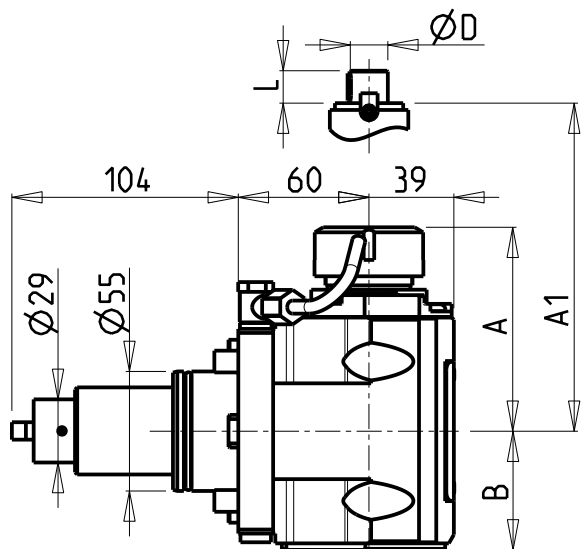

- Chiave inclusa
- Key included
- Schlüssel inbegriffen

Cod. MT	Mandrino Spindle Spindel	I	RPM	Coppia Max Max Torque Max Drehmoment	Reversibile lato mandrino/contromandrino Reversible sub/main spindle side Umkehrbare Spindel-seite/ Gegenspindel-seite	Lubr.interna Coolant through Innenkuehlung	Lubr. esterna Ext. coolant Aussenkuehlung	A	A1	B	D	L	CHIAVI NON INCLUDE Keys not included Schlüssel nicht einbegriffen		
DW 00870125	ER25	1:1	6000	50Nm	X	-	X	91.16	-	54.5	-	-	-	CHSTER25	OKU0650004 •
DW 00870225	ER25	1:1	6000	50Nm	X	P=70bar	X	91.16	-	65.5	-	-	-	CHSTER25	OKU0650004 •
DW 00870132	ER32	1:1	6000	50Nm	X	-	X	93.66	-	54.5	-	-	-	CHSTER32	OKU0650004 •
DW 00870232	ER32	1:1	6000	50Nm	X	P=70bar	X	93.66	-	65.5	-	-	-	CHSTER32	OKU0650004 •
DW 00870140	ER40	1:1	6000	50Nm	X	-	X	98.16	-	54.5	-	-	-	CHSTER40	OKU0650004 •
DW 00870240	ER40	1:1	6000	50Nm	X	P=70bar	X	98.16	-	65.5	-	-	-	CHSTER40	OKU0650004 •
DW 00870325	ERA25	1:1	6000	50Nm	X	-	X	65	-	54.5	-	-	CHUB27	CHTAER25ZC •	OKU0650004 •
DW 00870425	ERA25	1:1	6000	50Nm	X	P=70bar	X	65	-	65.5	-	-	CHUB27	CHTAER25ZC •	OKU0650004 •
DW 00870516	Ø16x17	1:1	6000	50Nm	X	-	X	-	67.5	54.5	16	17	-	CH_VTCROCE_M08 •	OKU0650004 •
DW 00870522	Ø22x19	1:1	6000	50Nm	X	-	X	-	67.5	54.5	22	19	-	CH_VTCROCE_M10 •	OKU0650004 •
DW 00870527	Ø27x21	1:1	6000	50Nm	X	-	X	-	70	54.5	27	21	-	CH_VTCROCE_M12 •	OKU0650004 •

SAMSUNG

MOD: PL240 LM - PL250 VM - SL1500/2000 M/Y/SY

MODULO MOTORIZZATO ASSIALE H=60mm

Axial driven tool H=60mm

Axial angetriebenes Werkzeug H=60mm

Subject to change without notice.

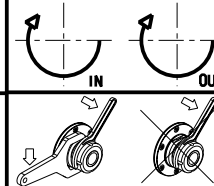

M.T. srl

Via Casino Albini 480
Tel. 0541/956034-957884
Fax 0541/956341

47842 S. GIOVANNI IN M. (RN)
e-mail: mtma@mtmarchetti.com
http://www.mtmarchetti.com

PRODUZIONE MODULI ROTANTI



PAGINA SMG150-5-11

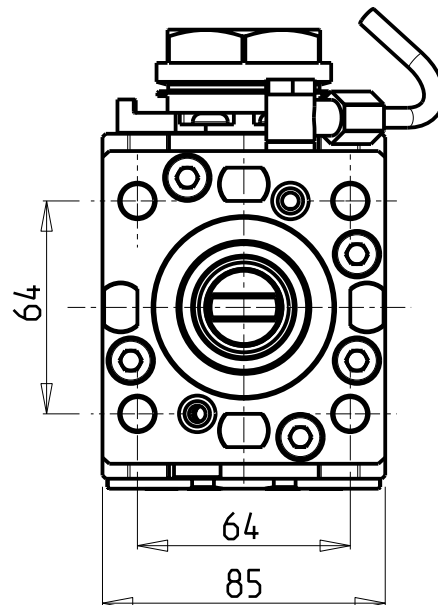
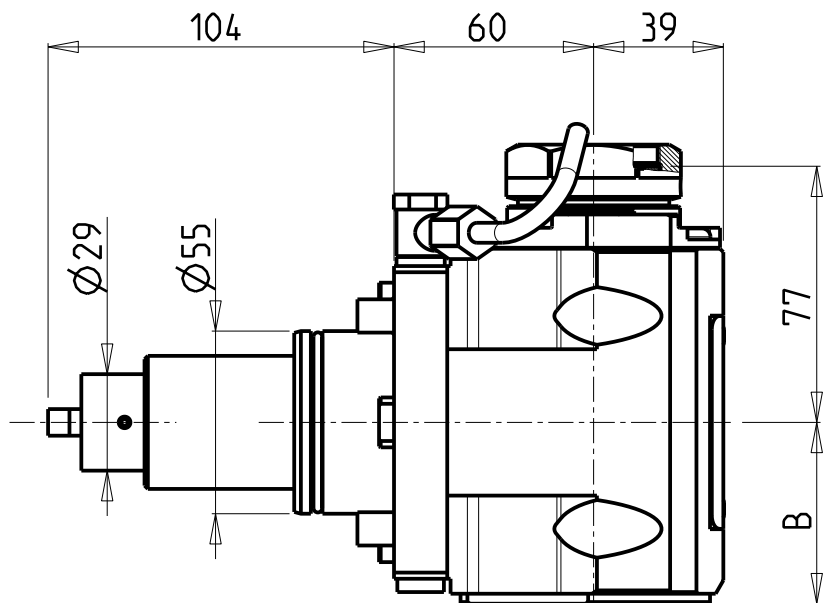

ATTENZIONE - ATTENTION - ACHTUNG

- Per lo smontaggio degli utensili utilizzare sempre la chiave di contrasto come indicato nel manuale d'uso.
- For disassembly of the tools use always the contrast key as mentioned in the user instructions.
- Fuer das Abmontieren der Werkzeuge immer den Gegenschlüssel benutzen wie in der Bedienungsanleitung erwäehnt.

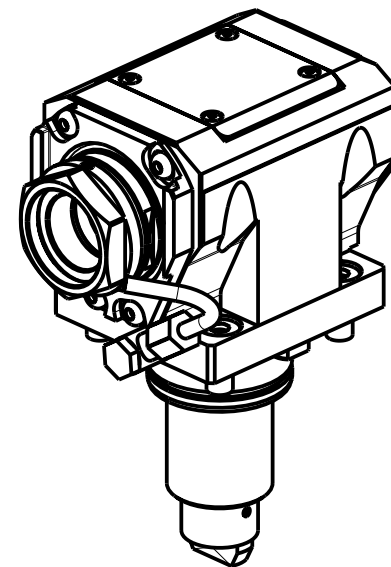

PER PORTAUTENSILI MODULARI MTSK-40 VEDI PAG. TBL300-1-40
 FOR MTSK-40 QUICK CHANGE TOOLHOLDERS CLAMPINGS SEE PAGE TBL300-1-40
 FUER MTSK-40 MODULARE WERKZEUGAUFNAHMEN SIEHE SEITE TBL300-1-40

Cod. MT	Mandrino Spindle Spindel	I	RPM	Coppia Max Max Torque Max Drehmoment	Reversibile lato mandrino/contromandrino Reversible sub/main spindle side Umkehrbare Spindel-seite/Gegenspindel-seite	Lubr.interna Coolant through Innenkuehlung	Lubr.esterna Ext. coolant Aussenkuehlung	B	CHIAVI NON INCLUDE Keys not included Schluessel nicht einbegriffen	
DW00770140	MTSK-40	1:1	6000	70Nm	X	-	X	54.5	CHUB46	OKU0650004 •
DW00770240	MTSK-40	1:1	6000	70Nm	X	P=70bar	X	65.5	CHUB46	OKU0650004 •

- Chiave inclusa
- Key included
- Schluessel inbegriffen

SAMSUNG

MOD: PL240 LM - PL250 VM - SL1500/2000 M/Y/SY

MODULO MOTORIZZATO ASSIALE MTSK H=60mm

Axial MTSK driven tool H=60mm

Axial MTSK angetriebenes Werkzeug H=60mm

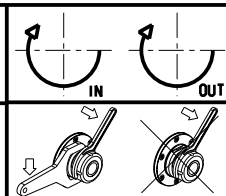

M.T. srl

Via Casino Albini 480
 Tel. 0541/956034-957884
 Fax 0541/956341

47842 S. GIOVANNI IN M. (RN)
 e-mail: mtma@mtmarchetti.com
 http://www.mtmarchetti.com

PRODUZIONE MODULI ROTANTI



PAGINA SMG150-5-11-K

Subject to change without notice.

10/2018

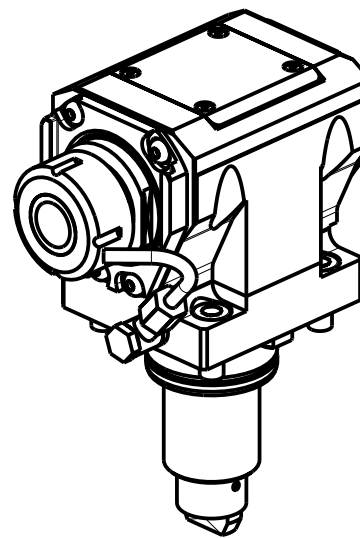
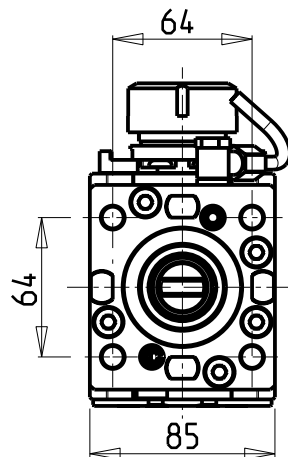
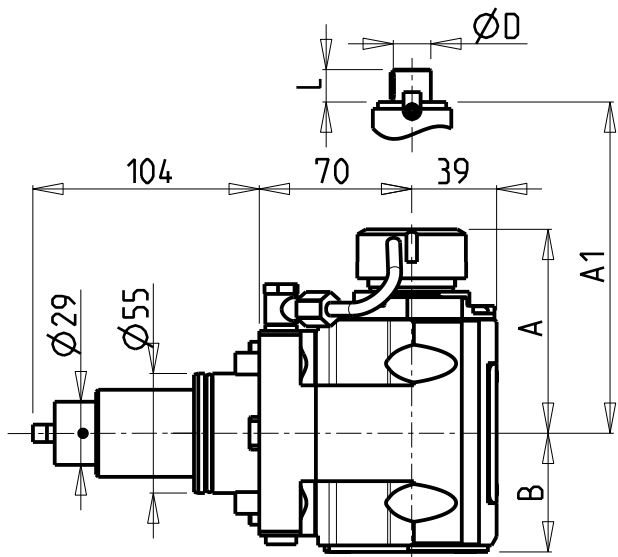

ATTENZIONE - ATTENTION - ACHTUNG

- VERIFICARE LE MISURE DI INGOMBRO PER POSSIBILE INTERFERENZA SU ALCUNI MODELLI DI MACCHINE
- Please check the overall sizes for possible interferences on some machine models
- Bitte überprüfen sie das ausmass um mögliche interferenzen auf einigen maschinen modellen zu vermeiden

- Chiave inclusa
- Key included
- Schluessel inbegriffen

Cod. MT	Mandrino Spindle Spindel	I	RPM	Coppia Max Max Torque Max Drehmoment	Reversibile lato mandrino/contromandrino Reversible sub/main spindle side Umkehrbare Spindel-seite/ Gegenspindel-seite	Lubr.interna Coolant through Innenkuehlung	Lubr. esterna Ext. coolant Aussenkuehlung	A	A1	B	D	L	CHIAVI NON INCLUDE Keys not included Schluessel nicht einbegriffen		
DW 00880125	ER25	1:1	6000	50Nm	X	-	X	91.16	-	54.5	-	-	-	CHSTER25	OKU0650004 *
DW 00880225	ER25	1:1	6000	50Nm	X	P=70bar	X	91.16	-	65.5	-	-	-	CHSTER25	OKU0650004 *
DW 00880132	ER32	1:1	6000	50Nm	X	-	X	93.66	-	54.5	-	-	-	CHSTER32	OKU0650004 *
DW 00880232	ER32	1:1	6000	50Nm	X	P=70bar	X	93.66	-	65.5	-	-	-	CHSTER32	OKU0650004 *
DW 00880140	ER40	1:1	6000	50Nm	X	-	X	98.16	-	54.5	-	-	-	CHSTER40	OKU0650004 *
DW 00880240	ER40	1:1	6000	50Nm	X	P=70bar	X	98.16	-	65.5	-	-	-	CHSTER40	OKU0650004 *
DW 00880325	ERA25	1:1	6000	50Nm	X	-	X	65	-	54.5	-	-	CHUB27	CHTAER25ZC *	OKU0650004 *
DW 00880425	ERA25	1:1	6000	50Nm	X	P=70bar	X	65	-	65.5	-	-	CHUB27	CHTAER25ZC *	OKU0650004 *
DW 00880516	Ø16x17	1:1	6000	50Nm	X	-	X	-	67.5	54.5	16	17	-	CH_VTCROCE_M08 *	OKU0650004 *
DW 00880522	Ø22x19	1:1	6000	50Nm	X	-	X	-	67.5	54.5	22	19	-	CH_VTCROCE_M10 *	OKU0650004 *
DW 00880527	Ø27x21	1:1	6000	50Nm	X	-	X	-	70	54.5	27	21	-	CH_VTCROCE_M12 *	OKU0650004 *

SAMSUNG
MOD: PL250 VM - SL1500/2000 M/Y/SY

MODULO MOTORIZZATO ASSIALE H=70mm
Axial driven tool H=70mm
Axial angetriebenes Werkzeug H=70mm

Subject to change without notice.

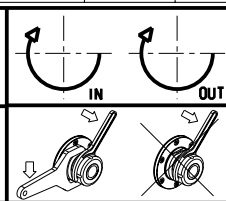

M.T. srl
Via Casino Albini 480
Tel. 0541/956034-957884
Fax 0541/956341
47842 S. GIOVANNI IN M. (RN)
e-mail: mtma@mtmarchetti.com
http://www.mtmarchetti.com

PRODUZIONE MODULI ROTANTI



PAGINA SMG150-5-21

ATTENZIONE - ATTENTION - ACHTUNG

- VERIFICARE LE MISURE DI INGOMBRO PER POSSIBILE INTERFERENZA SU ALCUNI MODELLI DI MACCHINE
- Please check the overall sizes for possible interferences on some machine models
- Bitte überprüfen sie das ausmass um mögliche interfeerenzen auf einigen maschinen modellen zu vermeiden

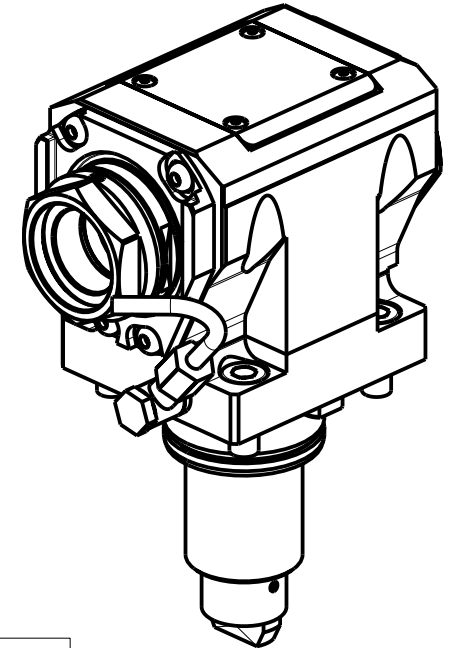
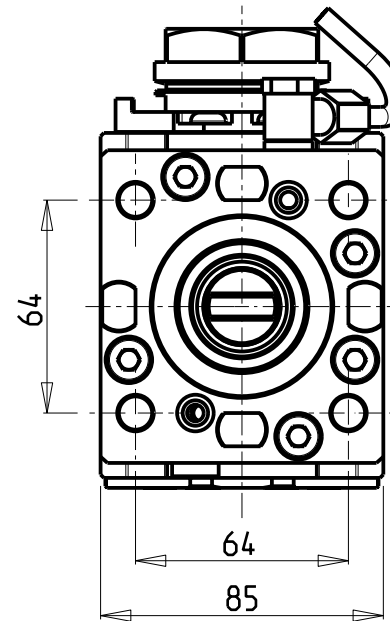
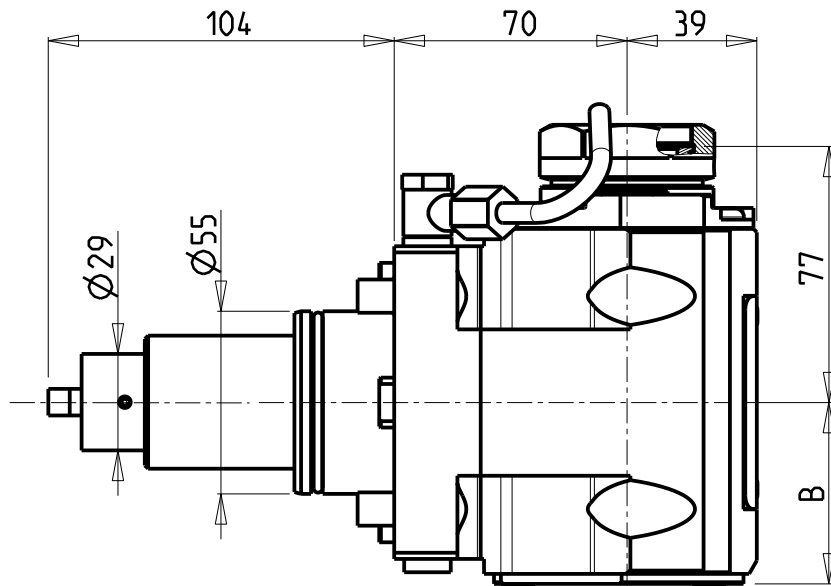

PER PORTAUTENSILI MODULARI MTSK-40 VEDI PAG. TBL300-1-40
 FOR MTSK-40 QUIK CHANGE TOOLHOLDERS CLAMPINGS SEE PAGE TBL300-1-40
 FUER MTSK-40 MODULARE WERKZEUGAUFNAHMEN SIEHE SEITE TBL300-1-40

Cod. MT	Mandrino Spindle Spindel	I	RPM	Coppia Max Max Torque Max Drehmoment	Reversibile lato mandrino/contromandrino Reversible sub/main spindle side Umkehrbare Spindel-seite/ Gegenspindel-seite	Lubr.interna Coolant through Innenkuehlung	Lubr.esterna Ext. coolant Aussenkuehlung	B	CHIAVI NON INCLUSE Keys not included Schlüssel nicht einbegriffen	
DW 00780140	MTSK-40	1:1	6000	70Nm	X	-	X	54.5	CHUB46	OKU0650004
DW 00780240	MTSK-40	1:1	6000	70Nm	X	P=70bar	X	65.5	CHUB46	OKU0650004

- Chiave inclusa
- Key included
- Schlüssel inbegriffen

SAMSUNG
 MOD: PL250 VM - SL1500/2000 M/Y/SY

MODULO MOTORIZZATO ASSIALE MTSK H=70mm
 Axial MTSK driven tool H=70mm
 Axial MTSK angetriebenes Werkzeug H=70mm

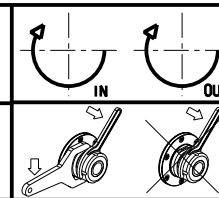

M.T. srl
 Via Casino Albini 480
 Tel. 0541/956034-957884
 Fax 0541/956341
 47842 S. GIOVANNI IN M. (RN)
 e-mail: mtma@mtmarchetti.com
 http://www.mtmarchetti.com

PRODUZIONE MODULI ROTANTI



PAGINA SMG150-5-21-K

Subject to change without notice.

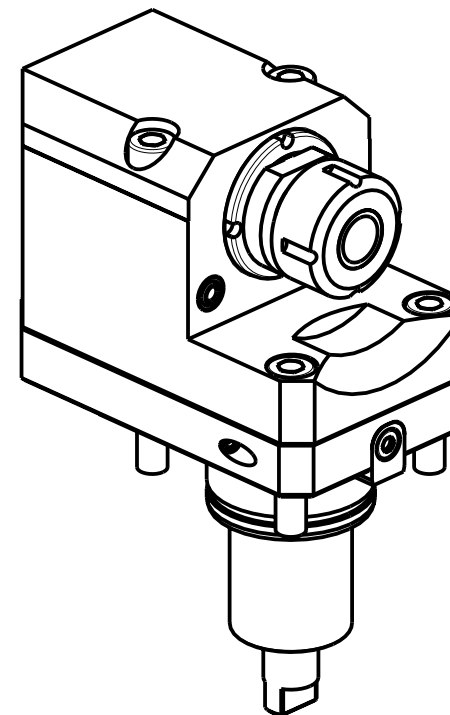
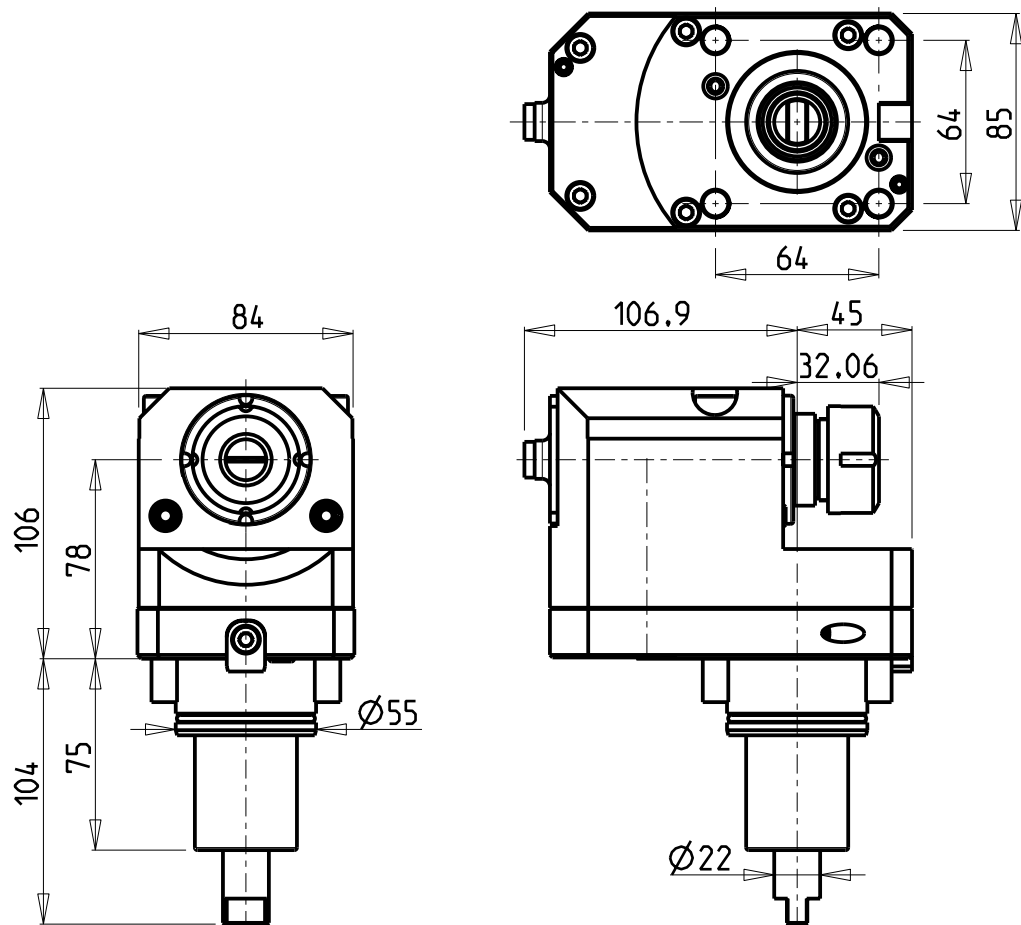

Cod. MT	Mandrino Spindle Spindel	I	RPM	Coppia Max Max Torque Max Drehmoment	Reversibile lato mandrino/contromandrino Reversible sub/main spindle side Umkehrbare Spindel-seite/ Gegenspindel-seite	Lubrificazione est. Ext. coolant Aussenkuehlung	CHIAVI NON INCLUSE Keys not included Schlüssel nicht einbegriffen	
0630025	ER25	1:1	6000	50Nm	X	X	CHSTER25	CHUB36

SAMSUNG
MOD: SL1500/2000 M/Y/SY

MODULO MOTORIZZATO ASSIALE ARRETRATO
Axial rear-set driven tool
Axial angetriebenes Werkzeug zurueckversetzt

Subject to change without notice.

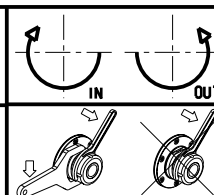

M.T. srl
Via Casino Albini 480
Tel. 0541/956034-957884
Fax 0541/956341
47842 S. GIOVANNI IN M. (RN)
e-mail: mtma@mtmarchetti.com
<http://www.mtmarchetti.com>

PRODUZIONE MODULI ROTANTI



PAGINA SMG180-5-10

ATTENZIONE - ATTENTION - ACHTUNG

- VERIFICARE LE MISURE DI INGOMBRO PER POSSIBILE INTERFERENZA SU ALCUNI MODELLI DI MACCHINE
- Please check the overall sizes for possible interferences on some machine models
- Bitte überprüfen sie das ausmass um mögliche interferenzen auf einigen maschinen modellen zu vermeiden

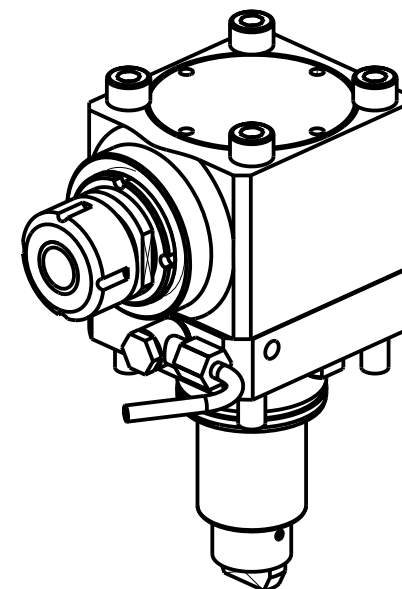
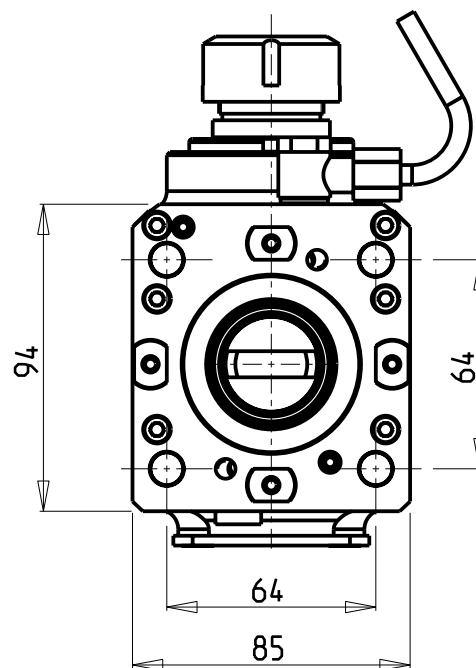
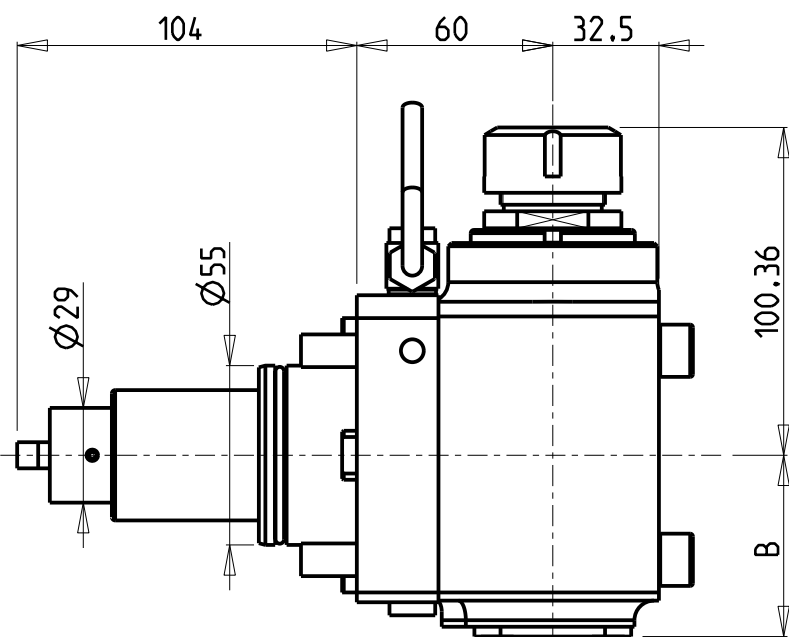

Cod. MT	Mandrino Spindle Spindel	I	RPM	Coppia Max Max Torque Max Drehmoment	Reversibile lato mandrino/contromandrino Reversible sub/main spindle side Umkehrbare Spindel-seite/ Gegenspindel-seite	Lubrificazione int. Coolant through Innenkuehlung	Lubrificazione est. Ext. coolant Aussenkuehlung	B	CHIAVI NON INCLUSE Keys not included Schluessel nicht einbegriffen	
									CHSTER25	CHUB36
0891225	ER25	1:2	12000	30Nm	X		X	55.5	CHSTER25	CHUB36
0891325	ER25	1:2	12000	30Nm	X	P=70bar	X	79	CHSTER25	CHUB36

SAMSUNG
 MOD: PL240 LM - PL250 VM - SL1500/2000 M/Y/SY
 MODULO MOTORIZZATO ASSIALE MOLTIPLICATO I=1:2 H=60mm
 Axial geared-up I=1:2 driven tool H=60mm
 Axial angetriebenes Werkzeug uebersetzt I=1:2 H=60mm

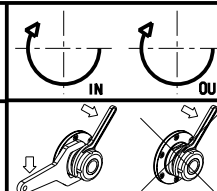

M.T. srl
 Via Casino Albini 480
 Tel. 0541/956034-957884
 Fax 0541/956341
 47842 S. GIOVANNI IN M. (RN)
 e-mail: mtma@mtmarchetti.com
 http://www.mtmarchetti.com

PRODUZIONE MODULI ROTANTI



PAGINA SMG200-5-10

Subject to change without notice.

ATTENZIONE - ATTENTION - ACHTUNG

- VERIFICARE LE MISURE DI INGOMBRO PER POSSIBILE INTERFERENZA SU ALCUNI MODELLI DI MACCHINE
- Please check the overall sizes for possible interferences on some machine models
- Bitte überprüfen sie das ausmass um mögliche interferenzen auf einigen maschinen modellen zu vermeiden

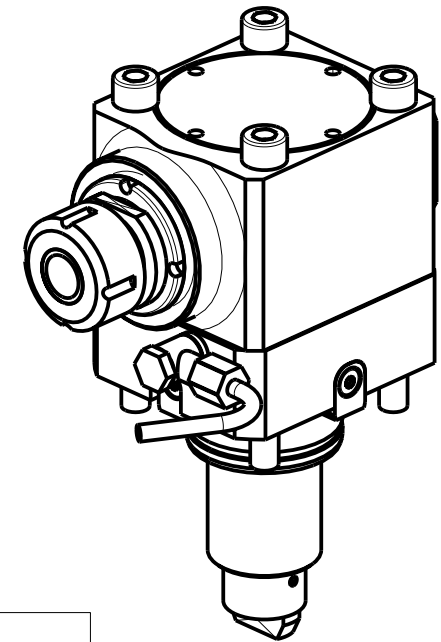
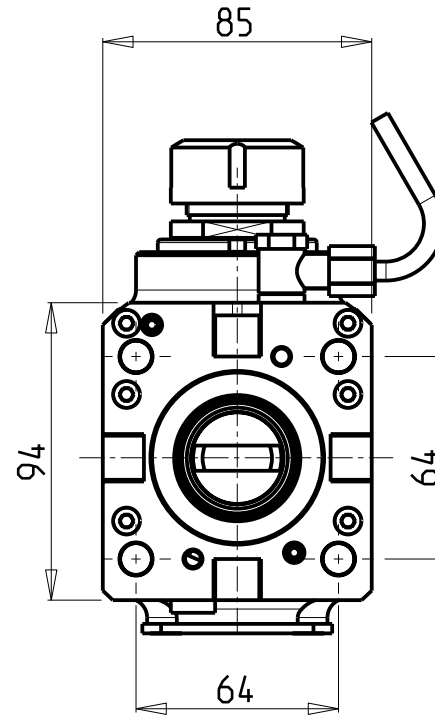
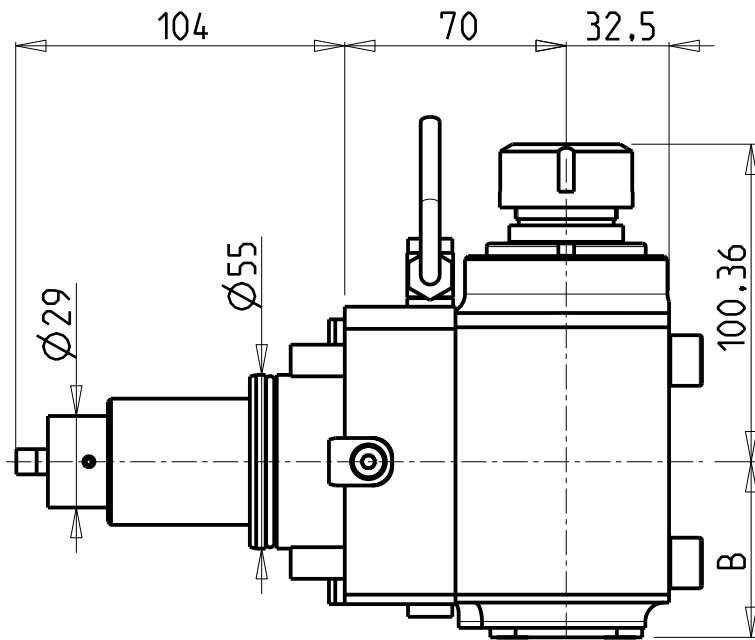

Cod. MT	Mandrino Spindle Spindel	I	RPM	Coppia Max Max Torque Max Drehmoment	Reversibile lato mandrino/contromandrino Reversible sub/main spindle side Umkehrbare Spindel-seite/ Gegenspindel-seite	Lubrificazione int. Coolant through Innenkuehlung	Lubrificazione est. Ext. coolant Aussenkuehlung	B	CHIAVI NON INCLUSE Keys not included Schluessel nicht einbegriffen	
									CHSTER25	CHUB36
0893625	ER25	1:2	12000	30Nm	X		X	55.5	CHSTER25	CHUB36
0893725	ER25	1:2	12000	30Nm	X	P=70bar	X	79	CHSTER25	CHUB36

SAMSUNG

MOD: PL240 LM - PL250 VM - SL1500/2000 M/Y/SY

MODULO MOTORIZZATO ASSIALE MOLTIPLICATO I=1:2 H=70mm

Axial geared-up I=1:2 driven tool H=70mm

Axial angetriebenes Werkzeug uebersetzt I=1:2 H=70mm

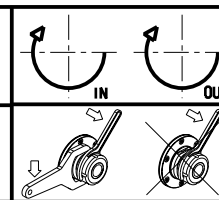

M.T. srl

Via Casino Albini 480
Tel. 0541/956034-957884
Fax 0541/956341
47842 S. GIOVANNI IN M. (RN)
e-mail: mtma@mtmarchetti.com
http://www.mtmarchetti.com

PRODUZIONE MODULI ROTANTI



PAGINA SMG200-5-20

Subject to change without notice.

10/2018

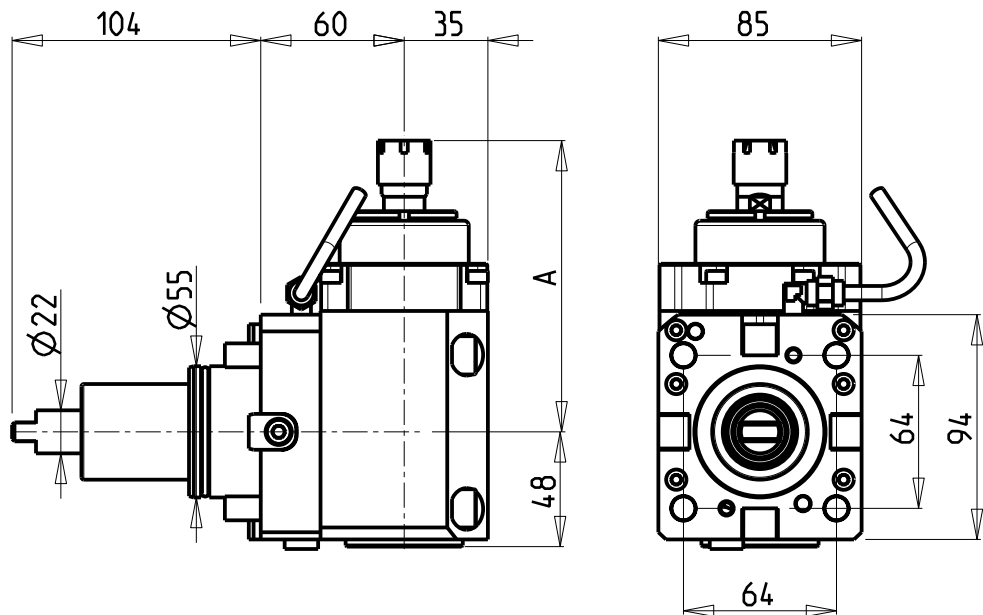

ATTENZIONE - ATTENTION - ACHTUNG

- VERIFICARE LE MISURE DI INGOMBRO PER POSSIBILE INTERFERENZA SU ALCUNI MODELLI DI MACCHINE
- Please check the overall sizes for possible interferences on some machine models
- Bitte überprüfen sie das ausmass um mögliche interferenzen auf einigen maschinen modellen zu vermeiden

ATTENZIONE - ATTENTION - ACHTUNG

- PRIMA DI UTILIZZARE IL MOTORIZZATO CONSULTARE LE ISTRUZIONI ALLEGATE!
- BEFORE USING THE DRIVEN TOOL, PLEASE CHECK THE ENCLOSED INSTRUCTION SHEET!
- VOR DER BENUTZUNG DES ANGETRIEBENEN WERKZEUGES, DIE BEILIEGENDEN INSTRUKTIONEN DURCHLESEN!

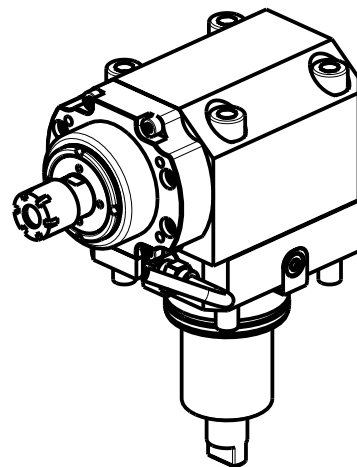

ATTENZIONE - ATTENTION - ACHTUNG

- Per lo smontaggio degli utensili utilizzare sempre la chiave di contrasto come indicato nel manuale d'uso.
- For disassembly of the tools use always the contrast key as mentioned in the user instructions.
- Fuer das Abmontieren der Werkzeuge immer den Gegenschluesel benutzen wie in der Bedienungsanleitung erwaeht.

Cod. MT	Mandrino Spindle Spindel	I	RPM MAX	Coppia Max Max Torque Max Drehmoment	Reversibile lato mandrino/contromandrino Reversible sub/main spindle side Umkehrbare Spindelseite/ Gegenspindelseite	Lubrificazione int. Coolant through Innenkuehlung	Lubrificazione est. Ext. coolant Aussenkuehlung	A	CHIAVI INCLUSE Keys included Schluessel einbegriffen	
DW 00190116	ER16	1:5.625	22500	6Nm	X		X	121.8	CHMNER16	CHUB17
DW 00190111	ER11	1:5.625	22500	6Nm	X	P=30bar		134	CHMNER11	CHUB11

SAMSUNG

MOD: PL240 LM - PL250 VM - SL1500/2000 M/Y/SY

MODULO MOTORIZZATO ASSIALE MOLTIPLICATO I=1:5.625 H=60mm

Axial geared-up I=1:5.625 driven tool H=60mm

Axial angetriebenes Werkzeug uebersetzt I=1:5.625 H=60mm

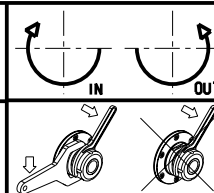

M.T. srl

Via Casino Albini 480
Tel. 0541/956034-957884
Fax 0541/956341

47842 S. GIOVANNI, IN M. (RN)
e-mail: mtma@mtmarchetti.com
http://www.mtmarchetti.com

PRODUZIONE MODULI ROTANTI



PAGINA SMG210-5-10

Subject to change without notice.

10/2018

ATTENZIONE - ATTENTION - ACHTUNG

- VERIFICARE LE MISURE DI INGOMBRO PER POSSIBILE INTERFERENZA SU ALCUNI MODELLI DI MACCHINE
- Please check the overall sizes for possible interferences on some machine models
- Bitte überprüfen sie das ausmass um mögliche interferenzen auf einigen maschinen modellen zu vermeiden

ATTENZIONE - ATTENTION - ACHTUNG

- PRIMA DI UTILIZZARE IL MOTORIZZATO CONSULTARE LE ISTRUZIONI ALLEGATE!
- BEFORE USING THE DRIVEN TOOL, PLEASE CHECK THE ENCLOSED INSTRUCTION SHEET!
- VOR DER BENUTZUNG DES ANGETRIEBENEN WERKZEUGES, DIE BEILIEGENDEN INSTRUKTIONEN DURCHLESEN!

ATTENZIONE - ATTENTION - ACHTUNG

- Per lo smontaggio degli utensili utilizzare sempre la chiave di contrasto come indicato nel manuale d'uso.
- For disassembly of the tools use always the contrast key as mentioned in the user instructions.
- Fuer das Abmontieren der Werkzeuge immer den Gegenschluesel benutzen wie in der Bedienungsanleitung erwaeht.

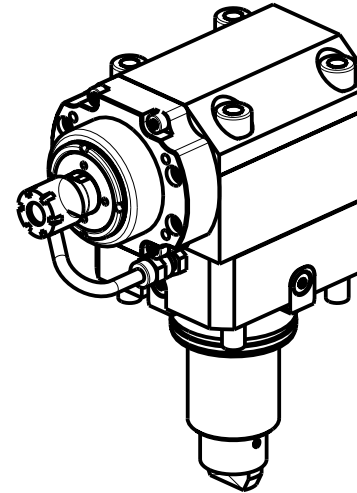
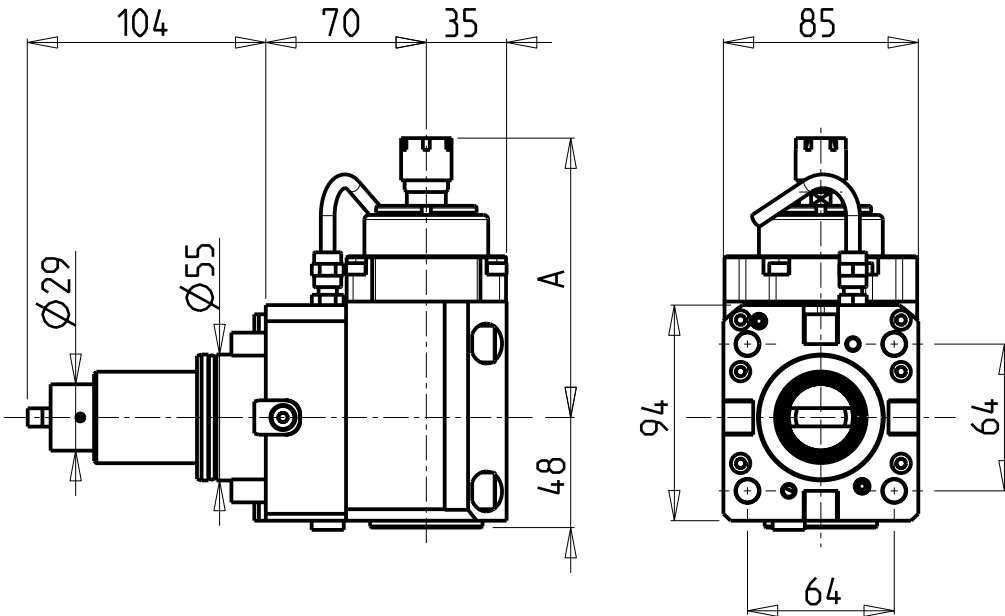

Cod. MT	Mandrino Spindle Spindel	I	RPM MAX	Coppia Max Max Torque Max Drehmoment	Reversibile lato mandrino/contromandrino Reversible sub/main spindle side Umkehrbare Spindel-seite/ Gegenspindel-seite	Lubrificazione int. Coolant through Innenkuehlung	Lubrificazione est. Ext. coolant Aussenkuehlung	A	CHIAVI INCLUSE Keys included Schluesel einbegriffen	
DW 00190316	ER16	1:5.625	22500	6Nm	X		X	121.8	CHMNER16	CHUB17
DW 00190311	ER11	1:5.625	22500	6Nm	X	P=30bar		134	CHMNER11	CHUB11

SAMSUNG

MOD: PL240 LM - PL250 VM - SL1500/2000 M/Y/SY

MODULO MOTORIZZATO ASSIALE MOLTIPLICATO I=1:5.625 H=70mm

Axial geared-up I=1:5.625 driven tool H=70mm

Axial angetriebenes Werkzeug uebersetzt I=1:5.625 H=70mm

Subject to change without notice.

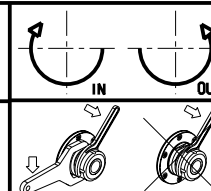

M.T. srl

Via Casino Albini 480
Tel. 0541/956034-957884
Fax 0541/956341
47842 S. GIOVANNI, IN M. (RN)
e-mail: mtma@mtmarchetti.com
http://www.mtmarchetti.com

PRODUZIONE MODULI ROTANTI



PAGINA SMG210-5-20

ATTENZIONE - ATTENTION - ACHTUNG

- VERIFICARE LE MISURE DI INGOMBRO PER POSSIBILE INTERFERENZA SU ALCUNI MODELLI DI MACCHINE
- Please check the overall sizes for possible interferences on some machine models
- Bitte überprüfen sie das ausmass um mögliche interferenzen auf einigen maschinen modellen zu vermeiden

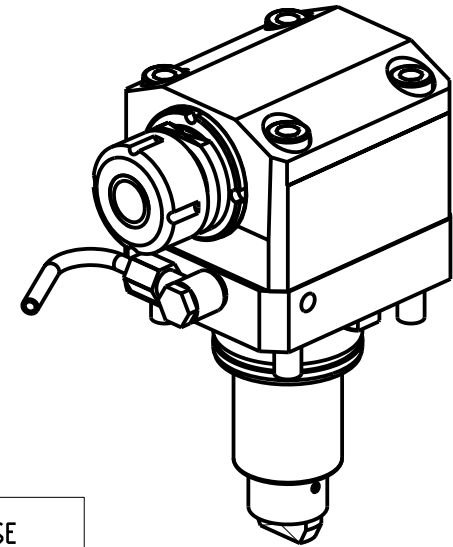
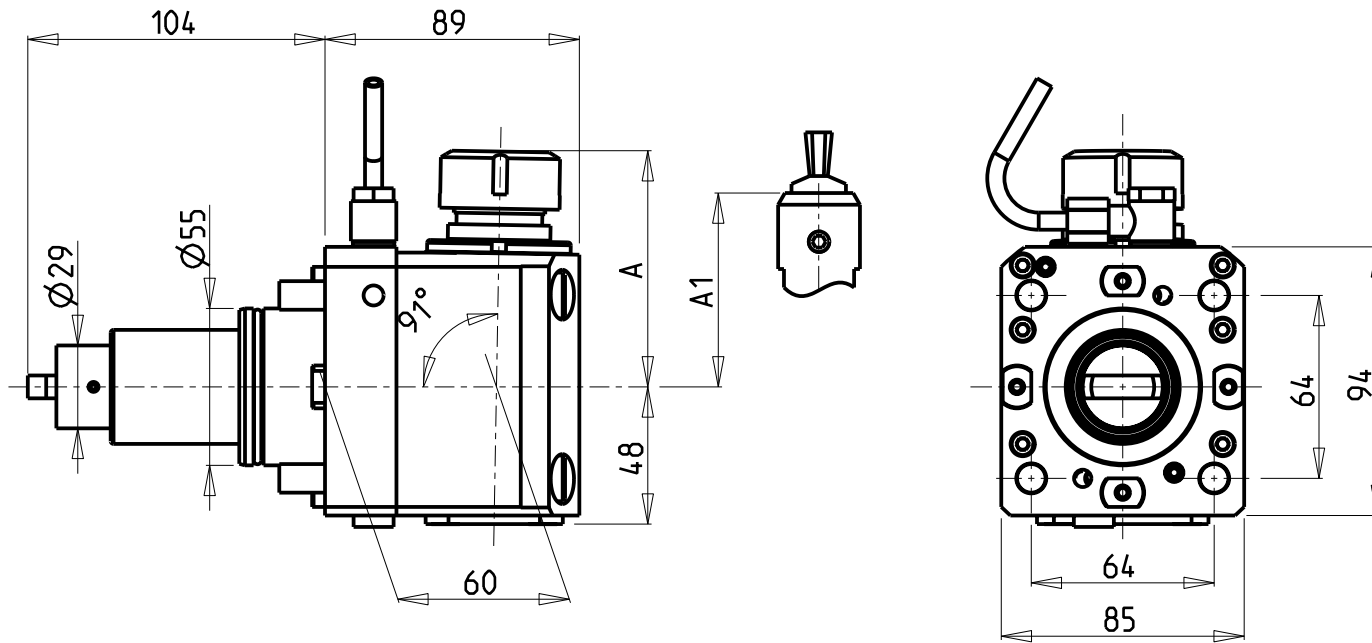

Cod. MT	Mandrino Spindle Spindel	I	RPM	Coppia Max Max Torque Max Drehmoment	Reversibile lato mandrino/contromandrino Reversible sub/main spindle side Umkehrbare Spindel-seite/ Gegenspindel-seite	Lubrificazione est. Ext. coolant Ausseukuehlung	A	A1	CHIAVI NON INCLUSE Keys not included Schluessel nicht einbegriffen
0319125	ER25	1:1	6000	50Nm	X	X	82.35	-	CHSTER25 CHUB36 o 0100000
0319108	WELDON 8	1:1	6000	50Nm	X	X	-	76.5	
0319110	WELDON 10	1:1	6000	50Nm	X	X	-	76.5	
0319112	WELDON 12	1:1	6000	50Nm	X	X	-	76.5	
0319116	WELDON 16	1:1	6000	50Nm	X	X	-	73.5	

SAMSUNG

MOD: PL240 LM - PL250 VM - SL1500/2000 M/Y/SY

MODULO MOTORIZZATO ASSIALE PER POLIGONATURA INTERNA H=60mm

Axial driven tool for internal polygon-making H=60mm

Axial angetriebenes Werkzeug fuer interne Facettierung H=60mm

Subject to change without notice.

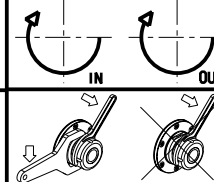

M.T. srl

Via Casino Albini 480
Tel. 0541/956034-957884

Fax 0541/956341

47842 S. GIOVANNI IN M. (RN)

e-mail: mtma@mtmarchetti.com

http://www.mtmarchetti.com

PRODUZIONE MODULI ROTANTI



PAGINA SMG230-5-10

ATTENZIONE - ATTENTION - ACHTUNG

- VERIFICARE LE MISURE DI INGOMBRO PER POSSIBILE INTERFERENZA SU ALCUNI MODELLI DI MACCHINE
- Please check the overall sizes for possible interferences on some machine models
- Bitte überprüfen sie das ausmass um mögliche interferenzen auf einigen maschinen modellen zu vermeiden

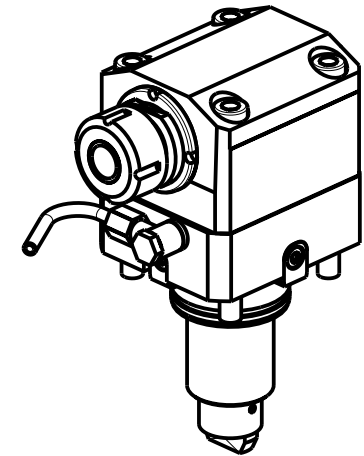
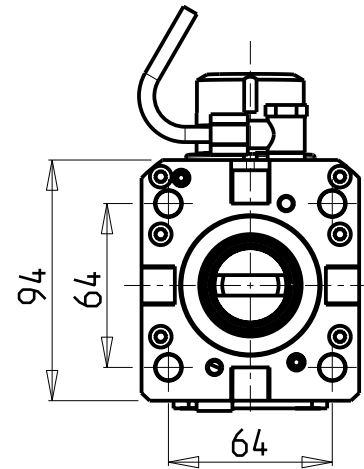
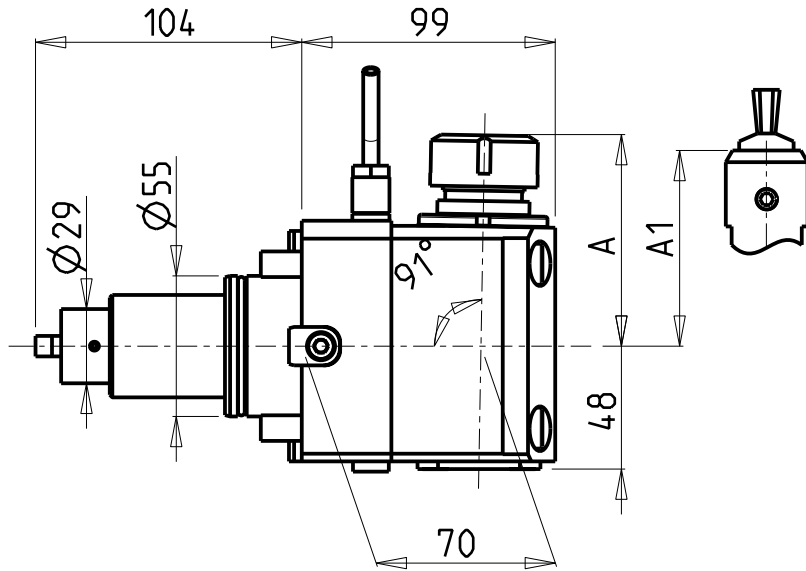

Cod. MT	Mandrino Spindle Spindel	I	RPM	Coppia Max Max Torque Max Drehmoment	Reversibile lato mandrino/contromandrino Reversible sub/main spindle side Umkehrbare Spindel-seite/Gegenspindel-seite	Lubrificazione est. Ext. coolant Ausseinkuehlung	A	A1	CHIAVI NON INCLUSE Keys not included Schluessel nicht einbegriffen
DW00249125	ER25	1:1	6000	50Nm	X	X	82.35	-	CHSTER25 CHUB36 o 0100000
DW00249108	WELDON 8	1:1	6000	50Nm	X	X	-	76.5	
DW00249110	WELDON 10	1:1	6000	50Nm	X	X	-	76.5	
DW00249112	WELDON 12	1:1	6000	50Nm	X	X	-	76.5	
DW00249116	WELDON 16	1:1	6000	50Nm	X	X	-	76.5	

SAMSUNG

MOD: PL240 LM - PL250 VM - SL1500/2000 M/Y/SY

MODULO MOTORIZZATO ASSIALE PER POLIGONATURA INTERNA H=70mm

Axial driven tool for internal polygon-making H=70mm

Axial angetriebenes Werkzeug fuer interne Facettierung H=70mm

Subject to change without notice.

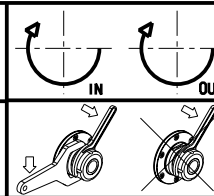

M.T. srl

Via Casino Albini 480
Tel. 0541/956034-957884

Fax 0541/956341

47842 S. GIOVANNI IN M. (RN)

e-mail: mtma@mtmarchetti.com

http://www.mtmarchetti.com

PRODUZIONE MODULI ROTANTI



PAGINA SMG230-5-20

ATTENZIONE - ATTENTION - ACHTUNG

- FINO AD ESAURIMENTO SCORTE
- clearance sale
- solange vorrat

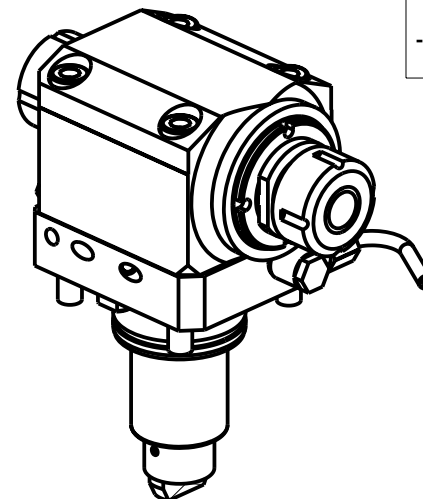
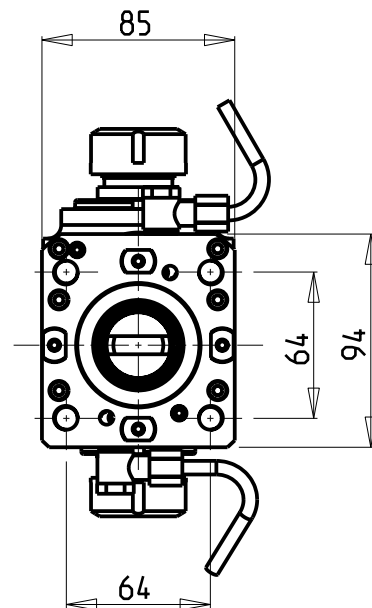
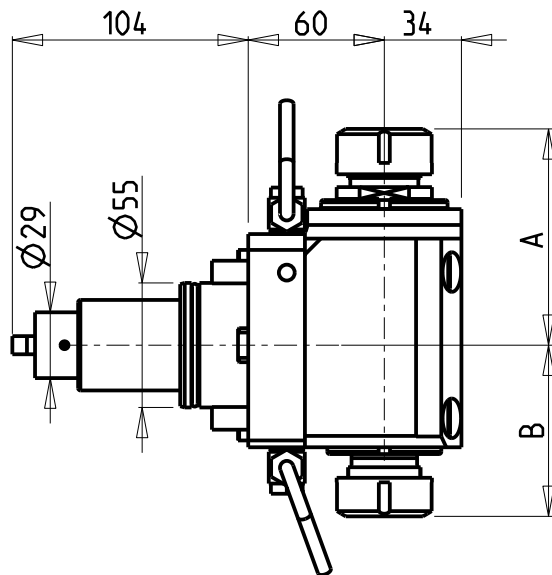

ATTENZIONE - ATTENTION - ACHTUNG

- Per lo smontaggio degli utensili utilizzare sempre la chiave di contrasto come indicato nel manuale d'uso.
- For disassembly of the tools use always the contrast key as mentioned in the user instructions.
- Fuer das Abmontieren der Werkzeuge immer den Gegenschlüssel benutzen wie in der Bedienungsanleitung erwaeht.

Cod. MT	Mandrino Spindle Spindel	I	RPM	Coppia Max Max Torque Max Drehmoment	Reversibile lato mandrino/contromandrino Reversible sub/main spindle side Umkehrbare Spindel-seite/ Gegenspindel-seite	Lubrificazione est. Ext. coolant Ausseukuehlung	A	B	CHIAVI NON INCLUSE Keys not included Schlüssel nicht einbegriffen	
DW00080132	ER32+ER32	1:1	6000	50Nm	X	X	100.56	79.46	CHSTER32	CHUB36 o 0100000
DW00080125	ER25+ER25	1:1	6000	50Nm	X	X	93.36	73.46	CHSTER25	CHUB36+CHUB29

SAMSUNG

MOD: SL1500/2000 M/Y/SY

MODULO MOTORIZZATO ASSIALE BISPORGENTE H=60mm

Axial opposite face twin driven tool H=60mm

Axial angetriebenes Werkzeug halb vorspringend H=60mm

Subject to change without notice.

M.T. srl

Via Casino Albini 480
Tel. 0541/956034-957884
Fax 0541/956341
47842 S. GIOVANNI IN M. (RN)
e-mail: mtma@mtmarchetti.com
http://www.mtmarchetti.com

PRODUZIONE MODULI ROTANTI



PAGINA SMG240-5-10

ATTENZIONE - ATTENTION - ACHTUNG

- Per lo smontaggio degli utensili utilizzare sempre la chiave di contrasto come indicato nel manuale d'uso.
- For disassembly of the tools use always the contrast key as mentioned in the user instructions.
- Fuer das Abmontieren der Werkzeuge immer den Gegenschlüssel benutzen wie in der Bedienungsanleitung erwaeht.

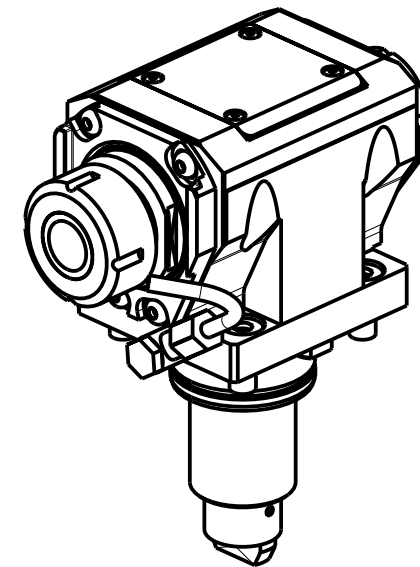
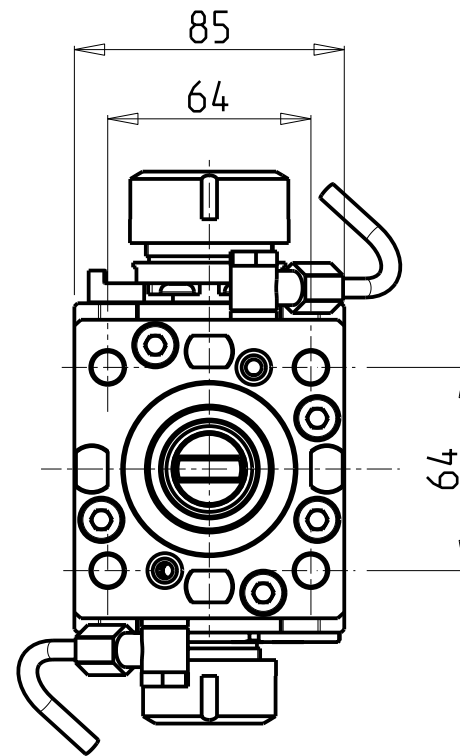
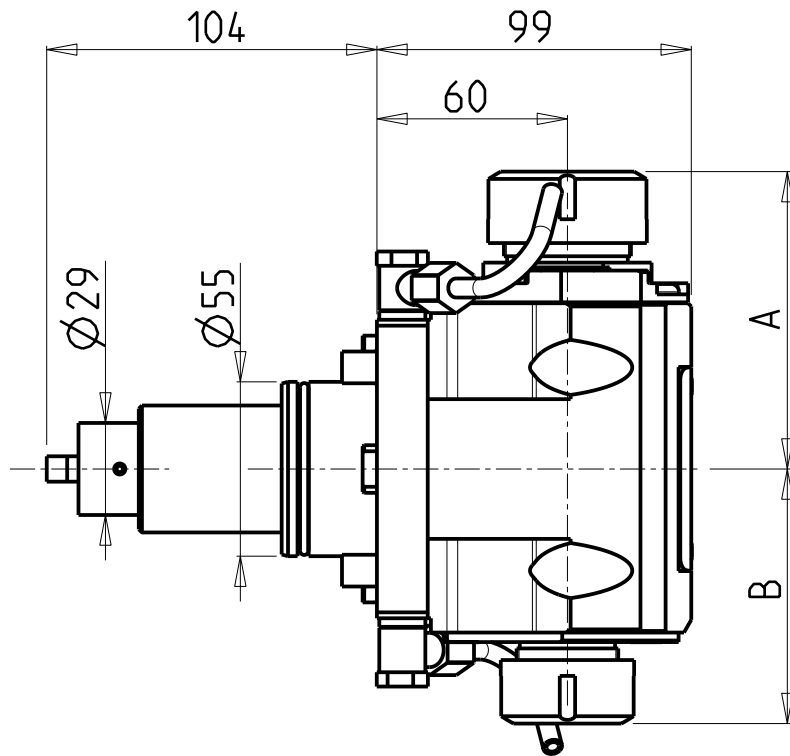

- Chiave inclusa
- Key included
- Schluessel inbegriffen

Cod. MT	Mandrino Spindle Spindel	I	RPM	Coppia Max Max Torque Max Drehmoment	Reversibile lato mandrino/contromandrino Reversible sub/main spindle side Umkehrbare Spindel-seite/ Gegenspindel-seite	Lubrificazione est. Ext. coolant Aussenkuehlung	A	B	CHIAVI NON INCLUSE Keys not included Schluessel nicht einbegriffen				
DW 01703225	ER32+ER25	1:1	6000	50Nm	X	X	93.66	80.16	CHSTER32	CHSTER25	OKU0650004	-	-
DW 01702520	ERA25+ERA20	1:1	6000	50Nm	X	X	65	55.5	CHUB22	CHUB27	OKU0650004	CHTAER20ZC	CHTAER25ZC

SAMSUNG
 MOD: SL1500/2000 M/Y/SY
 MODULO MOTORIZZATO ASSIALE BISPORGENTE H=60mm
 Axial opposite face twin driven tool H=60mm
 Axial angetriebenes Werkzeug halb vorspringend H=60mm

M.T. srl
 Via Casino Albini 480
 Tel. 0541/956034-957884
 Fax 0541/956341
 47842 S. GIOVANNI IN M. (RN)
 e-mail: mtma@mtmarchetti.com
 http://www.mtmarchetti.com

PRODUZIONE MODULI ROTANTI

 PAGINA SMG240-5-11

Subject to change without notice.

ATTENZIONE - ATTENTION - ACHTUNG

- FINO AD ESAURIMENTO SCORTE
- clearance sale
- solange vorrat

ATTENZIONE - ATTENTION - ACHTUNG

- VERIFICARE LE MISURE DI INGOMBRO PER POSSIBILE INTERFERENZA SU ALCUNI MODELLI DI MACCHINE
- Please check the overall sizes for possible interferences on some machine models
- Bitte überprüfen sie das ausmass um mögliche interferenzen auf einigen maschinen modellen zu vermeiden

ATTENZIONE - ATTENTION - ACHTUNG

- Per lo smontaggio degli utensili utilizzare sempre la chiave di contrasto come indicato nel manuale d'uso.
- For disassembly of the tools use always the contrast key as mentioned in the user instructions.
- Fuer das Abmontieren der Werkzeuge immer den Gegenschlüssel benutzen wie in der Bedienungsanleitung erwaeht.

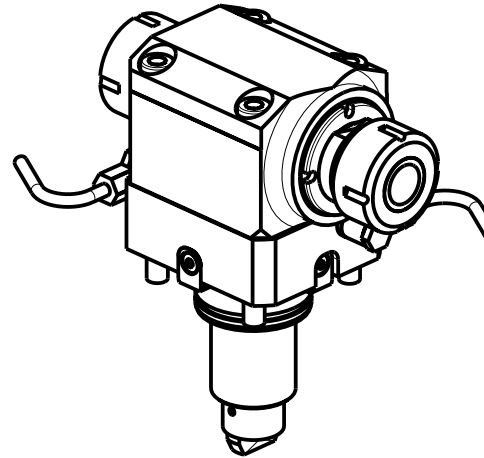
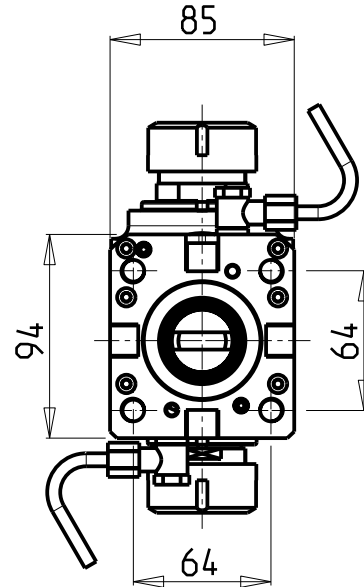
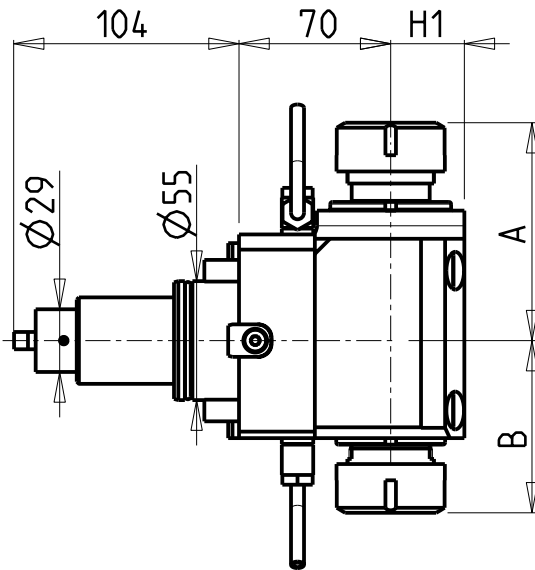

Cod. MT	Mandrino Spindle Spindel	I	RPM	Coppia Max Max Torque Max Drehmoment	Reversibile lato mandrino/contromandrino Reversible sub/main spindle side Umkehrbare Spindelseite/ Gegenspindelseite	Lubrificazione est. Ext. coolant Aussekkuehlung	A	B	H1	CHIAVI NON INCLUSE Keys not included Schlüssel nicht einbegriffen	
DW00080332	ER32+ER32	1:1	6000	50Nm	X	X	100.56	79.46	34	CHSTER32	CHUB36 o 0100000
DW00080325	ER25+ER25	1:1	6000	50Nm	X	X	93.36	73.46	34	CHSTER25	CHUB36+CHUB29

SAMSUNG

MOD: SL1500/2000 M/Y/SY

MODULO MOTORIZZATO ASSIALE BISPORGENTE H=70mm

Axial opposite face twin driven tool H=70mm

Axial angetriebenes Werkzeug halb vorspringend H=70mm

Subject to change without notice.

M.T. srl

Via Casino Albini 480
Tel. 0541/956034-957884
Fax 0541/956341
47842 S. GIOVANNI IN M. (RN)
e-mail: mtma@mtmarchetti.com
http://www.mtmarchetti.com

PRODUZIONE MODULI ROTANTI



PAGINA SMG240-5-20

ATTENZIONE - ATTENTION - ACHTUNG

- Per lo smontaggio degli utensili utilizzare sempre la chiave di contrasto come indicato nel manuale d'uso.
- For disassembly of the tools use always the contrast key as mentioned in the user instructions.
- Fuer das Abmontieren der Werkzeuge immer den Gegenschlüssel benutzen wie in der Bedienungsanleitung erwaeht.

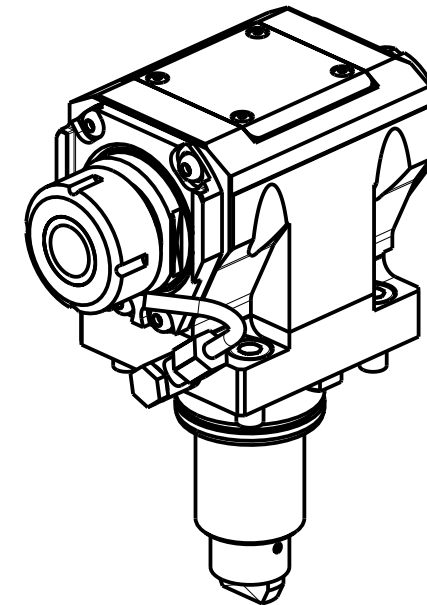
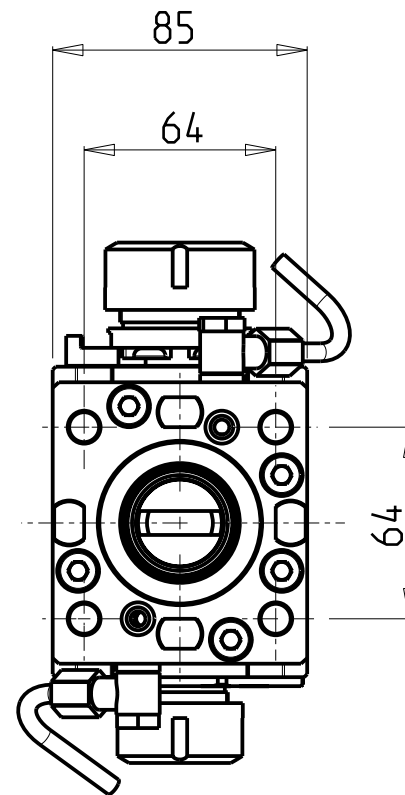
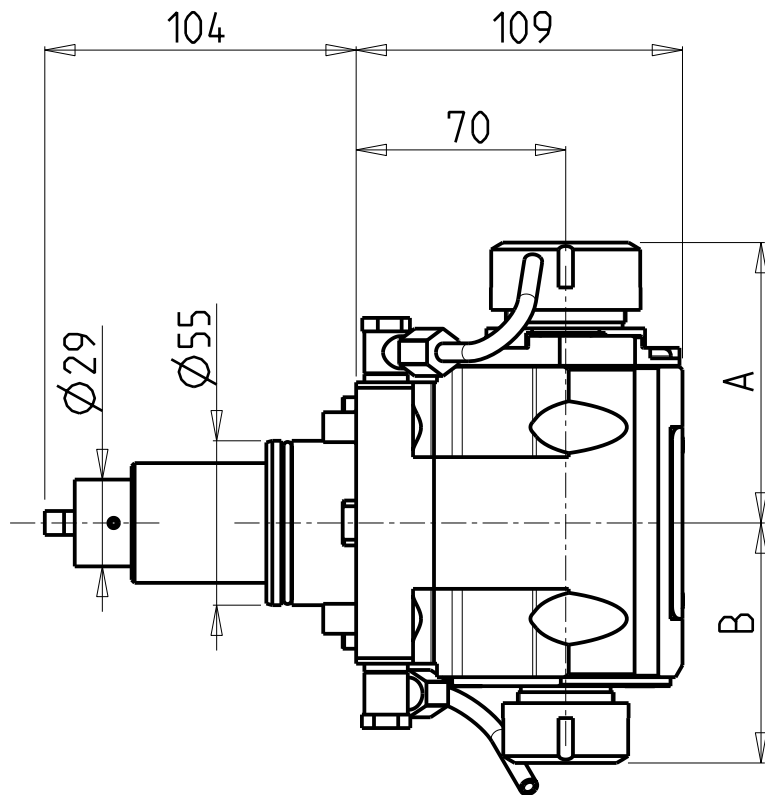

- Chiave inclusa
- Key included
- Schlüssel inbegriffen

Cod. MT	Mandrino Spindle Spindel	I	RPM	Coppia Max Max Torque Max Drehmoment	Reversibile lato mandrino/contromandrino Reversible sub/main spindle side Umkehrbare Spindelsete/Gegenspindelsete	Lubrificazione est. Ext. coolant Aussenkuehlung	A	B	CHIAVI NON INCLUSE Keys not included Schlüssel nicht einbegriffen					
DW 01713225	ER32+ER25	1:1	6000	50Nm	X	X	93.66	80.16	CHSTER32	CHSTER25	OKU0650004	-	-	-
DW 01712520	ERA25+ERA20	1:1	6000	50Nm	X	X	65	55.5	CHUB22	CHUB27	OKU0650004	CHTAER20ZC	CHTAER25ZC	

SAMSUNG
 MOD: SL1500/2000 M/Y/SY
 MODULO MOTORIZZATO ASSIALE BISPORGENTE H=70mm
 Axial opposite face twin driven tool H=70mm
 Axial angetriebenes Werkzeug halb vorspringend H=70mm

M.T. srl
 Via Casino Albini 480
 Tel. 0541/956034-957884
 Fax 0541/956341
 47842 S. GIOVANNI IN M. (RN)
 e-mail: mtma@mtmarchetti.com
 http://www.mtmarchetti.com

PRODUZIONE MODULI ROTANTI

 PAGINA SMG240-5-21

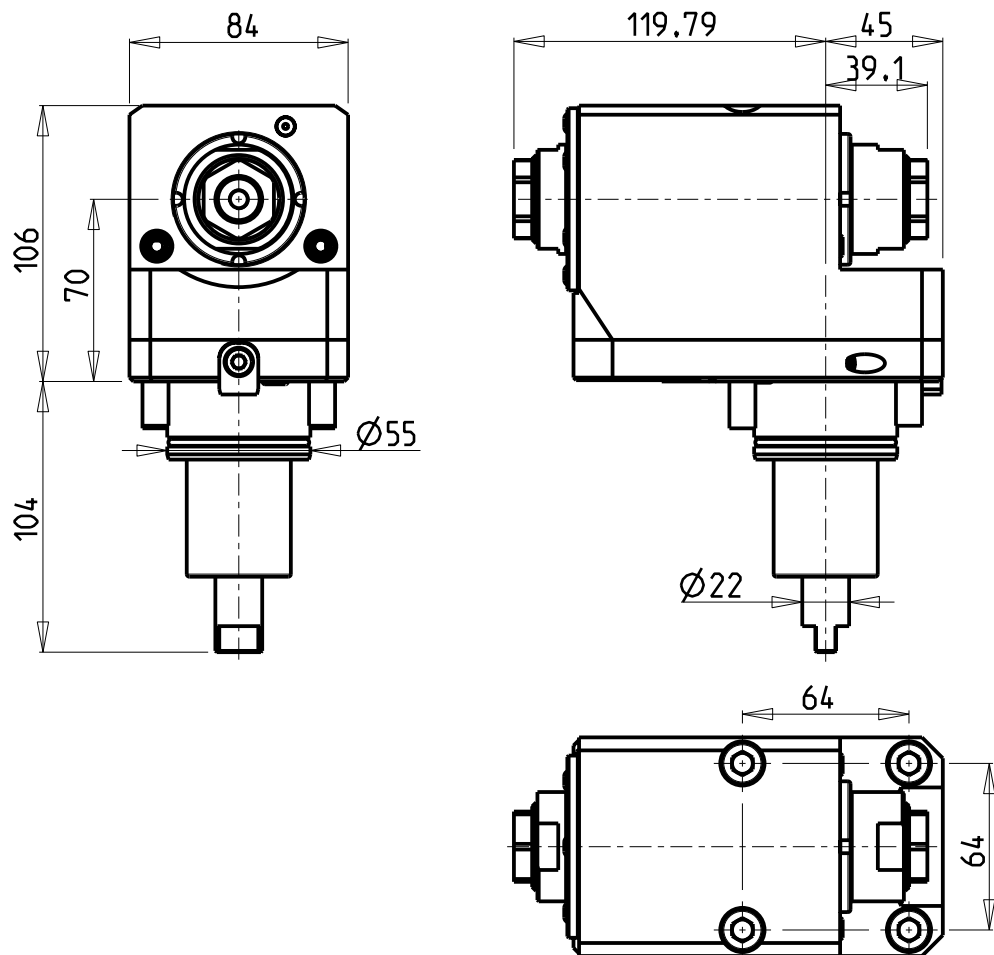
Subject to change without notice.

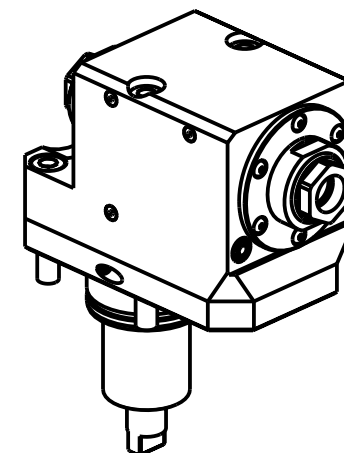
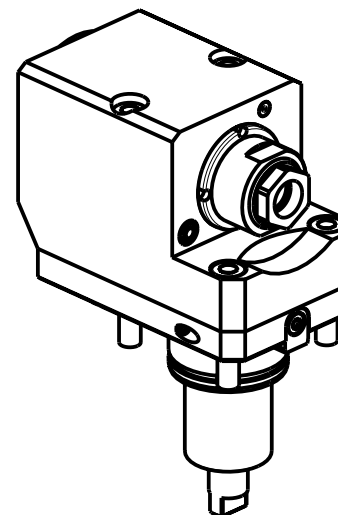

ATTENZIONE - ATTENTION - ACHTUNG

- Per lo smontaggio degli utensili utilizzare sempre la chiave di contrasto come indicato nel manuale d'uso.
- For disassembly of the tools use always the contrast key as mentioned in the user instructions.
- Fuer das Abmontieren der Werkzeuge immer den Gegenschlüssel benutzen wie in der Bedienungsanleitung erwäehnt.



Cod. MT	Mandrino Spindle Spindel	I	RPM	Coppia Max Max Torque Max Drehmoment	Reversibile lato mandrino/contromandrino Reversible sub/main spindle side Umkehrbare Spindel-seite/ Gegenspindel-seite	Lubrificazione est. Ext. coolant Aussenkuehlung	CHIAVI NON INCLUSE Keys not included Schluessel nicht inbegriffen	
0632525	ERA25+ERA25	1:1	6000	50Nm	X	X	CHUB27	CHUB38

SAMSUNG

MOD: SL1500/2000 M/Y/SY

MODULO MOTORIZZATO ASSIALE ARRETRATO BISPORGENTE

Axial opposite face rear-set driven tool

Axial angetriebenes Werkzeug zurueckversetzt halb vorspringend

Subject to change without notice.

M.T. srl

Via Casino Albini 480
Tel. 0541/956034-957884
Fax 0541/956341
47842 S. GIOVANNI IN M. (RN)
e-mail: mtma@mtmarchetti.com
http://www.mtmarchetti.com

PRODUZIONE MODULI ROTANTI



PAGINA SMG243-5-10

ATTENZIONE - ATTENTION - ACHTUNG

- Per lo smontaggio degli utensili utilizzare sempre la chiave di contrasto come indicato nel manuale d'uso.
- For disassembly of the tools use always the contrast key as mentioned in the user instructions.
- Fuer das Abmontieren der Werkzeuge immer den Gegenschlüssel benutzen wie in der Bedienungsanleitung erwaeht.

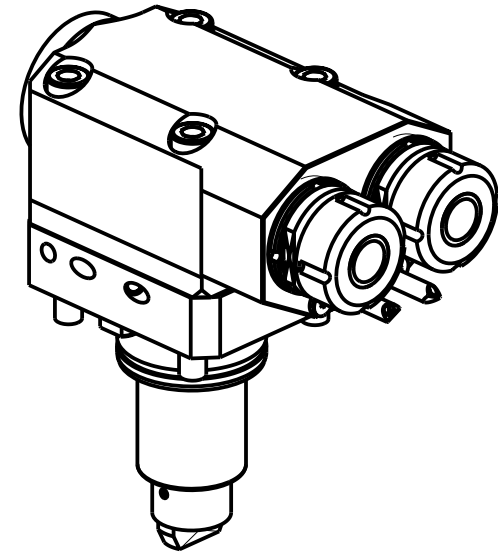
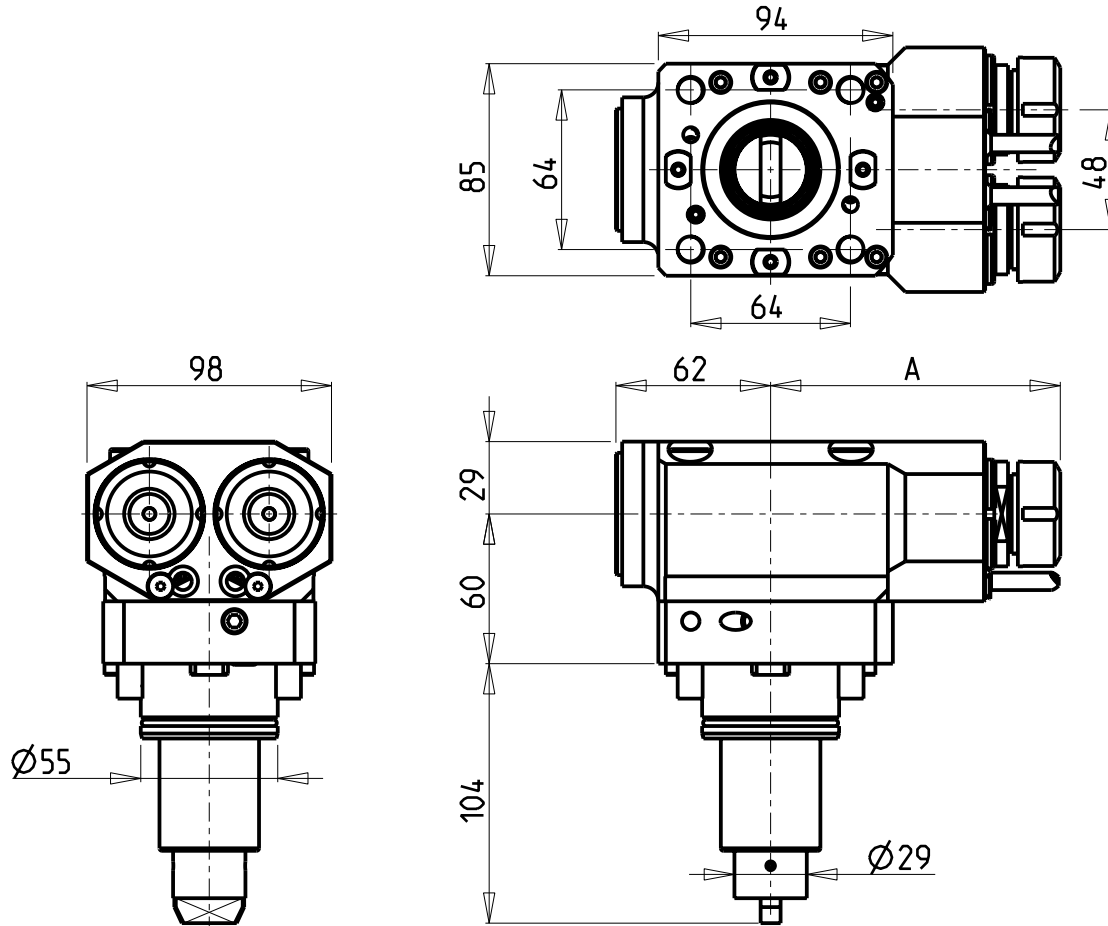

Cod. MT	Mandrino Spindle Spindel	I	RPM	Coppia Max Max Torque Max Drehmoment	Reversibile lato mandrino/contromandrino Reversible sub/main spindle side Umkehrbare Spindel-seite/ Gegenspindel-seite	Lubrificazione est. Ext. coolant Aussenkuehlung	A	CHIAVI NON INCLUSE Keys not included Schluessel nicht einbegriffen	
					X			X	CHMNER16
DW00100216	ER16	1:1	6000	30Nm	X	X	115.15	CHMNER16	CHUB17
DW00100225	ER25	1:1	6000	30Nm	X	X	115.61	CHSTER25	MNL0210007

SAMSUNG
MOD: SL1500/2000 Y/SY

MODULO MOTORIZZATO ASSIALE 2 USCITE IN Y H=60mm
Axial single side twin head driven tool in Y H=60mm
Axial angetriebenes Werkzeug 2 Ausgaenge in Y H=60mm

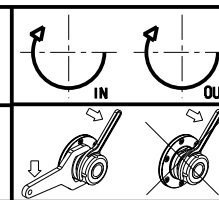

M.T. srl
Via Casino Albini 480
Tel. 0541/956034-957884
Fax 0541/956341
47842 S. GIOVANNI IN M. (RN)
e-mail: mtma@mtmarchetti.com
http://www.mtmarchetti.com

PRODUZIONE MODULI ROTANTI



PAGINA SMG260-5-10

Subject to change without notice.

10/2018

ATTENZIONE - ATTENTION - ACHTUNG

- Per lo smontaggio degli utensili utilizzare sempre la chiave di contrasto come indicato nel manuale d'uso.
- For disassembly of the tools use always the contrast key as mentioned in the user instructions.
- Fuer das Abmontieren der Werkzeuge immer den Gegenschlüssel benutzen wie in der Bedienungsanleitung erwäehnt.

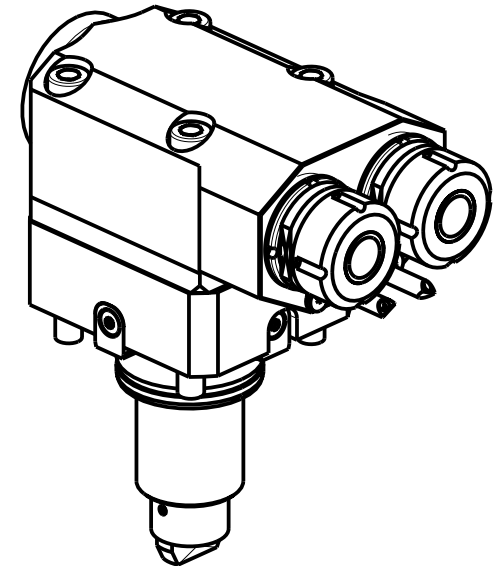
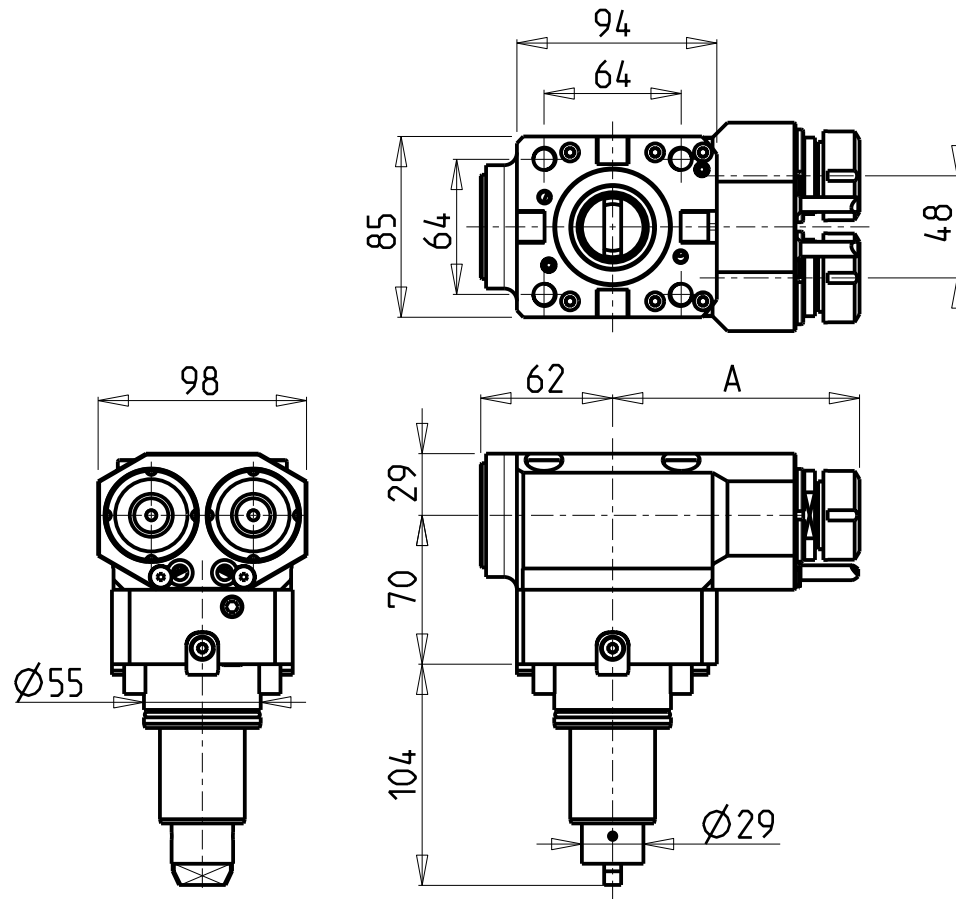

Cod. MT	Mandrino Spindle Spindel	I	RPM	Coppia Max Max Torque Max Drehmoment	Reversibile lato mandrino/contromandrino Reversible sub/main spindle side Umkehrbare Spindel-seite/ Gegenspindel-seite	Lubrificazione est. Ext. coolant Aussenkuehlung	A	CHIAVI NON INCLUSE Keys not included Schluessel nicht einbegriffen	
					X			X	
DW 00102216	ER16	1:1	6000	30Nm	X	X	115.15	CHMNER16	CHUB17
DW 00102225	ER25	1:1	6000	30Nm	X	X	115.61	CHSTER25	MNL0210007

SAMSUNG

MOD: SL1500/2000 Y/SY

MODULO MOTORIZZATO ASSIALE 2 USCITE IN Y H=70mm

Axial single side twin head driven tool in Y H=70mm

Axial angetriebenes Werkzeug 2 Ausgaenge in Y H=70mm

Subject to change without notice.

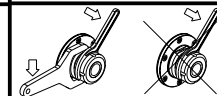
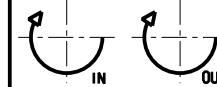

M.T. srl

Via Casino Albini 480
Tel. 0541/956034-957884

Fax 0541/956341

47842 S. GIOVANNI IN M. (RN)

e-mail: mtma@mtmarchetti.com

http://www.mtmarchetti.com

PRODUZIONE MODULI ROTANTI



PAGINA SMG260-5-20

ATTENZIONE - ATTENTION - ACHTUNG

- Per lo smontaggio degli utensili utilizzare sempre la chiave di contrasto come indicato nel manuale d'uso.
- For disassembly of the tools use always the contrast key as mentioned in the user instructions.
- Fuer das Abmontieren der Werkzeuge immer den Gegenschlüssel benutzen wie in der Bedienungsanleitung erwaeht.

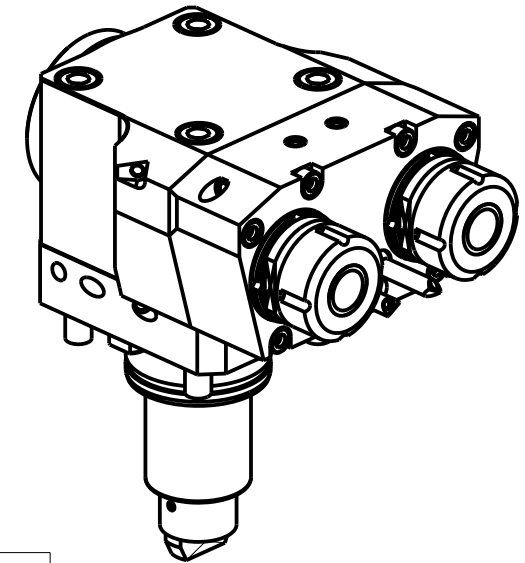
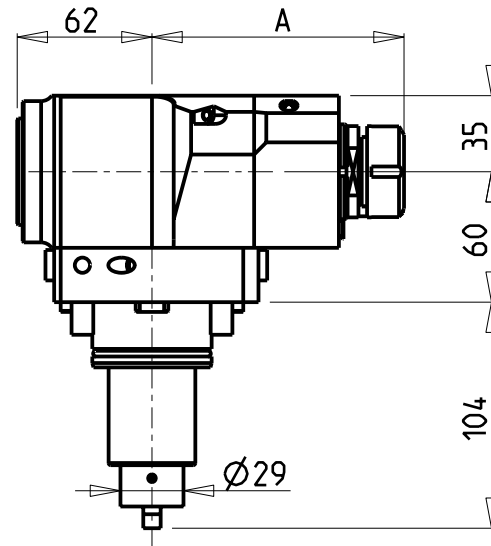
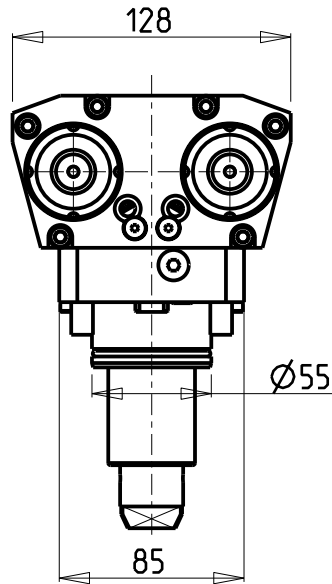
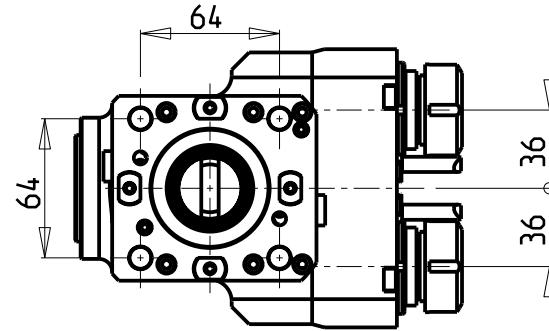

Cod. MT	Mandrino Spindle Spindel	I	RPM	Coppia Max Max Torque Max Drehmoment	Reversibile lato mandrino/contromandrino Reversible sub/main spindle side Umkehrbare Spindel-seite/ Gegenspindel-seite	Lubrificazione est. Ext. coolant Aussenkuehlung	A	CHIAVI NON INCLUSE Keys not included Schluessel nicht einbegriffen	
DW00950216	ER16	1:2	12000	20Nm	X	X	115	CHMNER16	CHUB17
DW00950225	ER25	1:2	12000	20Nm	X	X	115.96	CHSTER25	CHUB36

SAMSUNG

MOD: SL1500/2000 Y/SY

MODULO MOTORIZZATO ASSIALE 2 USCITE IN Y MOLTIPLICATO I=1:2 H=60mm

Axial geared-up I=1:2 single side twin head driven tool in Y H=60mm

Axial angetriebenes Werkzeug 2 Ausgaenge in Y uebersetzt I=1:2 H=60mm

Subject to change without notice.

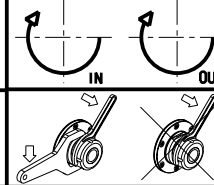

M.T. srl

Via Casino Albini 480
Tel. 0541/956034-957884
Fax 0541/956341
47842 S. GIOVANNI IN M. (RN)
e-mail: mtma@mtmarchetti.com
http://www.mtmarchetti.com

PRODUZIONE MODULI ROTANTI



PAGINA SMG261-5-10

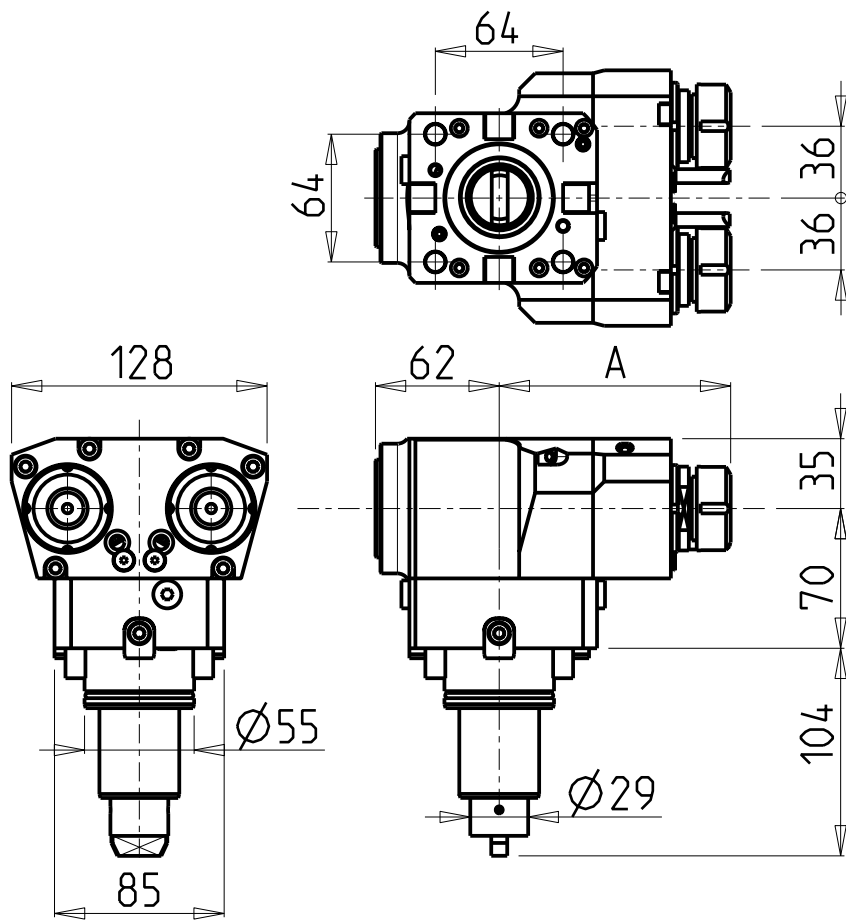

ATTENZIONE - ATTENTION - ACHTUNG

- Per lo smontaggio degli utensili utilizzare sempre la chiave di contrasto come indicato nel manuale d'uso.
- For disassembly of the tools use always the contrast key as mentioned in the user instructions.
- Fuer das Abmontieren der Werkzeuge immer den Gegenschlüssel benutzen wie in der Bedienungsanleitung erwahnt.

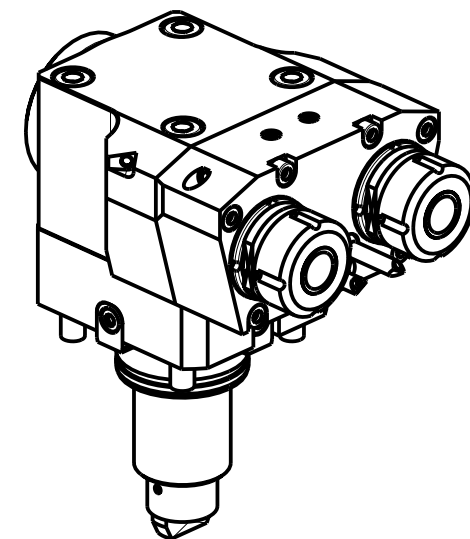

Cod. MT	Mandrino Spindle Spindel	I	RPM	Coppia Max Max Torque Max Drehmoment	Reversibile lato mandrino/contromandrino Reversible sub/main spindle side Umkehrbare Spindelsete/Gegenspindelsete	Lubrificazione est. Ext. coolant Aussenkuehlung	A	CHIAVI NON INCLUSE Keys not included Schluessel nicht einbegriffen	
								CHMNER16	CHUB17
DW 00951216	ER16	1:2	12000	20Nm	X	X	115	CHMNER16	CHUB17
DW 00951225	ER25	1:2	12000	20Nm	X	X	115.96	CHSTER25	CHUB36

SAMSUNG
MOD: SL1500/2000 Y/SY

MODULO MOTORIZZATO ASSIALE 2 USCITE IN Y MOLTIPLICATO I=1:2 H=70mm
Axial geared-up I=1:2 single side twin head driven tool in Y H=70mm
Axial angetriebenes Werkzeug 2 Ausgaenge in Y uebersetzt I=1:2 H=70mm

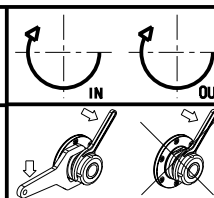

M.T. srl
Via Casino Albini 480
Tel. 0541/956034-957884
Fax 0541/956341
47842 S. GIOVANNI IN M. (RN)
e-mail: mtma@mtmarchetti.com
http://www.mtmarchetti.com

PRODUZIONE MODULI ROTANTI



PAGINA SMG261-5-20

Subject to change without notice.

10/2018

ATTENZIONE - ATTENTION - ACHTUNG

- VERIFICARE LE MISURE DI INGOMBRO PER POSSIBILE INTERFERENZA SU ALCUNI MODELLI DI MACCHINE
- Please check the overall sizes for possible interferences on some machine models
- Bitte überprüfen sie das ausmass um mögliche interferenzen auf einigen maschinen modellen zu vermeiden

ATTENZIONE - ATTENTION - ACHTUNG

- Per lo smontaggio degli utensili utilizzare sempre la chiave di contrasto come indicato nel manuale d'uso.
- For disassembly of the tools use always the contrast key as mentioned in the user instructions.
- Fuer das Abmontieren der Werkzeuge immer den Gegenschlüssel benutzen wie in der Bedienungsanleitung erwahnt.

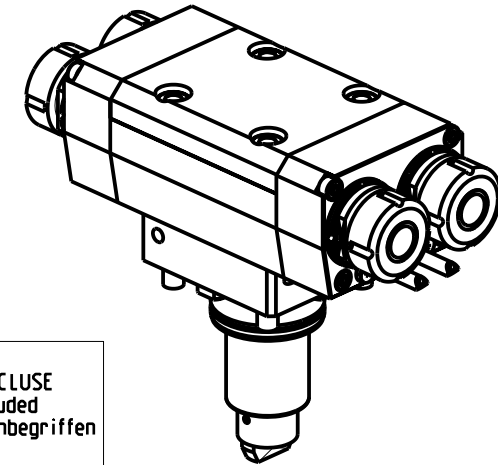
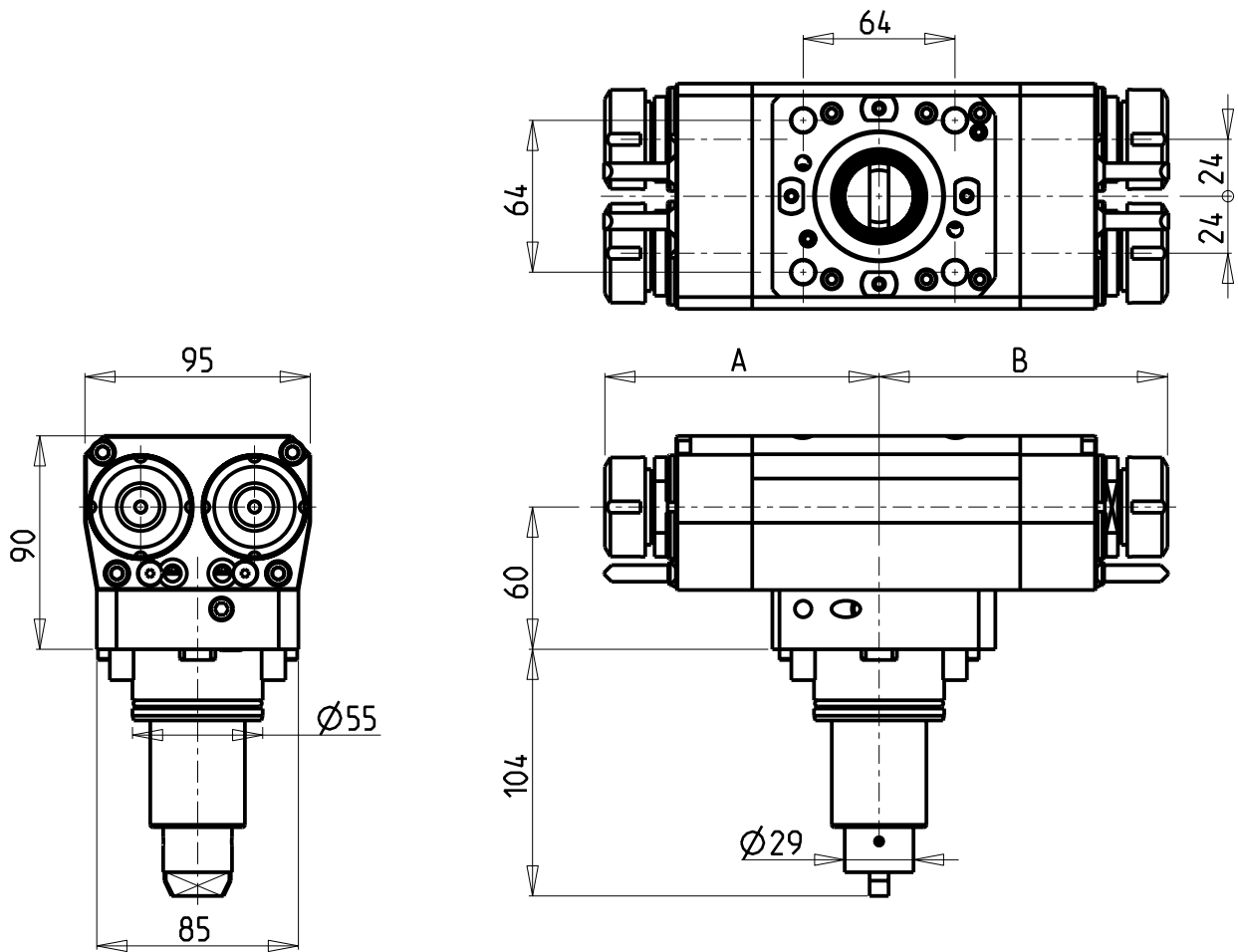

Cod. MT	Mandrino Spindle Spindel	I	RPM	Coppia Max Max Torque Max Drehmoment	Reversibile lato mandrino/contromandrino Reversible sub/main spindle side Umkehrbare Spindel-seite/ Gegenspindel-seite	N°Utensili N°Tools N°Werkzeuge	Lubrificazione est. Ext. coolant Aussehenkuehlung	A	B	CHIAVI NON INCLUSE Keys not included Schluessel nicht einbegriffen	
DW 02401416	ER16+ER16	1:1	6000	50Nm	X	2+2	X	114.7	120.7	CHUB17	CHMNER16
DW 02401425	ER25+ER25	1:1	6000	50Nm	X	2+2	X	115.6	121.6	CHUB36	CHSTER25

SAMSUNG

MOD: SL1500/2000 Y/SY

MODULO MOTORIZZATO ASSIALE 2+2 USCITE IN Y H=60mm

Axial multiple 2+2 outlet driven tool in Y H=60mm

Axial angetriebenes Mehrspindel-Werkzeug 2+2 Ausgaenge in Y H=60mm

Subject to change without notice.

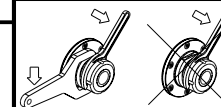

M.T. srl

Via Casino Albini 480
Tel. 0541/956034-957884
Fax 0541/956341
47842 S. GIOVANNI IN M. (RN)
e-mail: mtma@mtmarchetti.com
http://www.mtmarchetti.com

PRODUZIONE MODULI ROTANTI



PAGINA SMG268-5-10

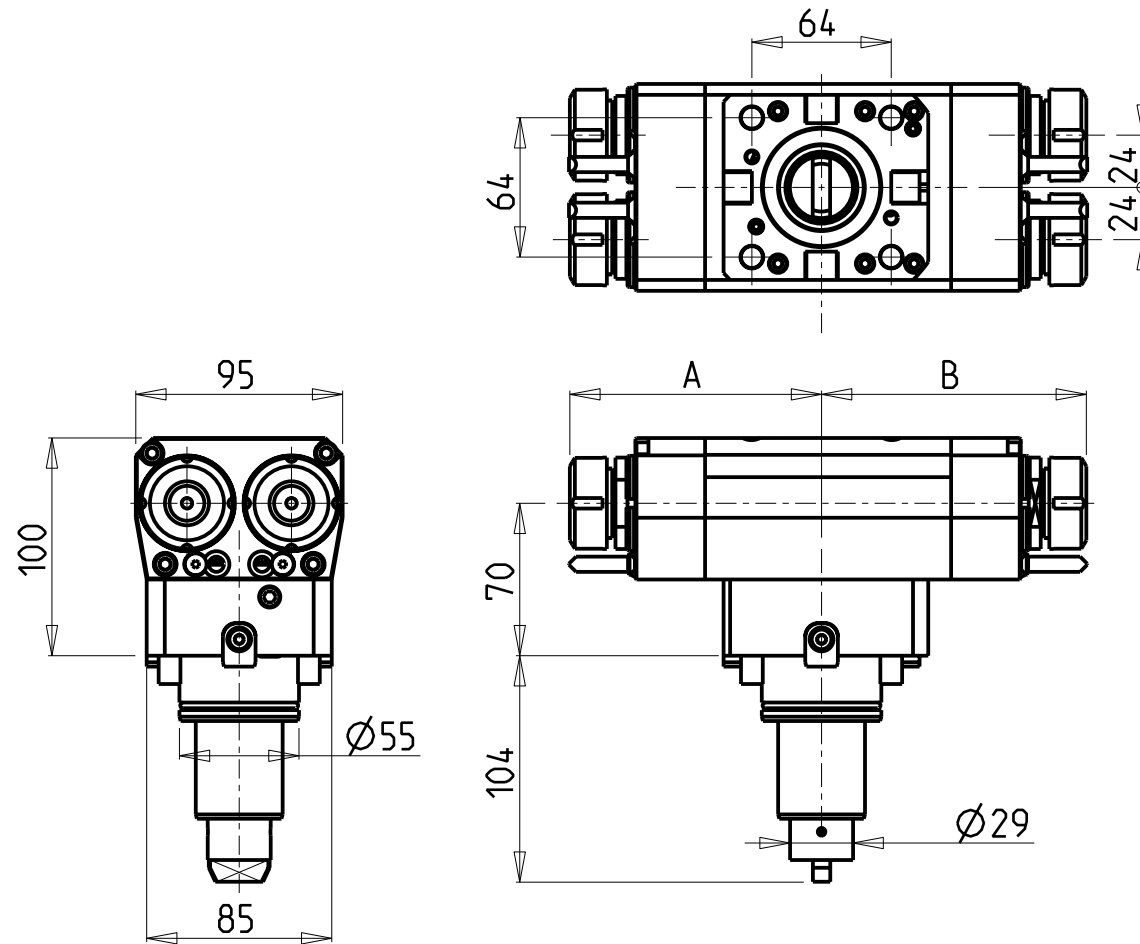

ATTENZIONE - ATTENTION - ACHTUNG

- VERIFICARE LE MISURE DI INGOMBRO PER POSSIBILE INTERFERENZA SU ALCUNI MODELLI DI MACCHINE
- Please check the overall sizes for possible interferences on some machine models
- Bitte überprüfen sie das ausmass um mögliche interferenzen auf einigen maschinen modellen zu vermeiden

ATTENZIONE - ATTENTION - ACHTUNG

- Per lo smontaggio degli utensili utilizzare sempre la chiave di contrasto come indicato nel manuale d'uso.
- For disassembly of the tools use always the contrast key as mentioned in the user instructions.
- Fuer das Abmontieren der Werkzeuge immer den Gegenschluessel benutzen wie in der Bedienungsanleitung erwaeht.

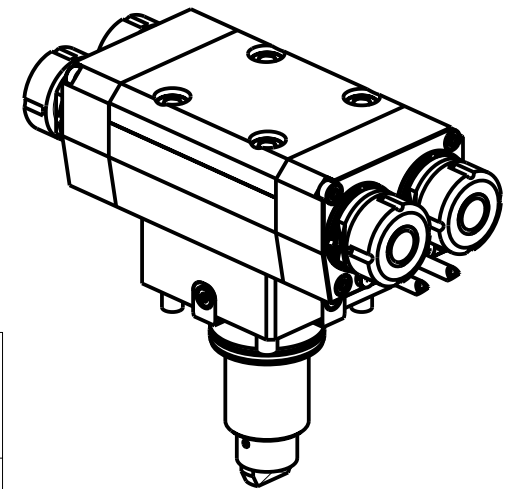

Cod. MT	Mandrino Spindle Spindel	I	RPM	Coppia Max Max Torque Max Drehmoment	Reversibile lato mandrino/contromandrino Reversible sub/main spindle side Umkehrbare Spindel-seite/ Gegenspindel-seite	N°Utensili N°Tools N°Werkzeuge	Lubrificazione est. Ext. coolant Aussenkuehlung	A	B	CHIAVI NON INCLUSE Keys not included Schluessel nicht einbegriffen	
DW 02400416	ER16+ER16	1:1	6000	50Nm	X	2+2	X	114.7	120.7	CHUB17	CHMNER16
DW 02400425	ER25+ER25	1:1	6000	50Nm	X	2+2	X	115.6	121.6	CHUB36	CHSTER25

SAMSUNG
 MOD: SL1500/2000 Y/SY
 MODULO MOTORIZZATO ASSIALE 2+2 USCITE IN Y H=70mm
 Axial multiple 2+2 outlet driven tool in Y H=70mm
 Axial angetriebenes Mehrspindel-Werkzeug 2+2 Ausgaenge in Y H=70mm

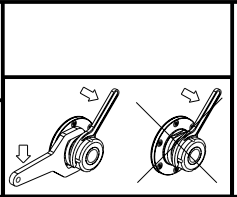

M.T. srl
 Via Casino Albini 480
 Tel. 0541/956034-957884
 Fax 0541/956341
 47842 S. GIOVANNI IN M. (RN)
 e-mail: mtma@mtmarchetti.com
 http://www.mtmarchetti.com

PRODUZIONE MODULI ROTANTI

 PAGINA SMG268-5-20

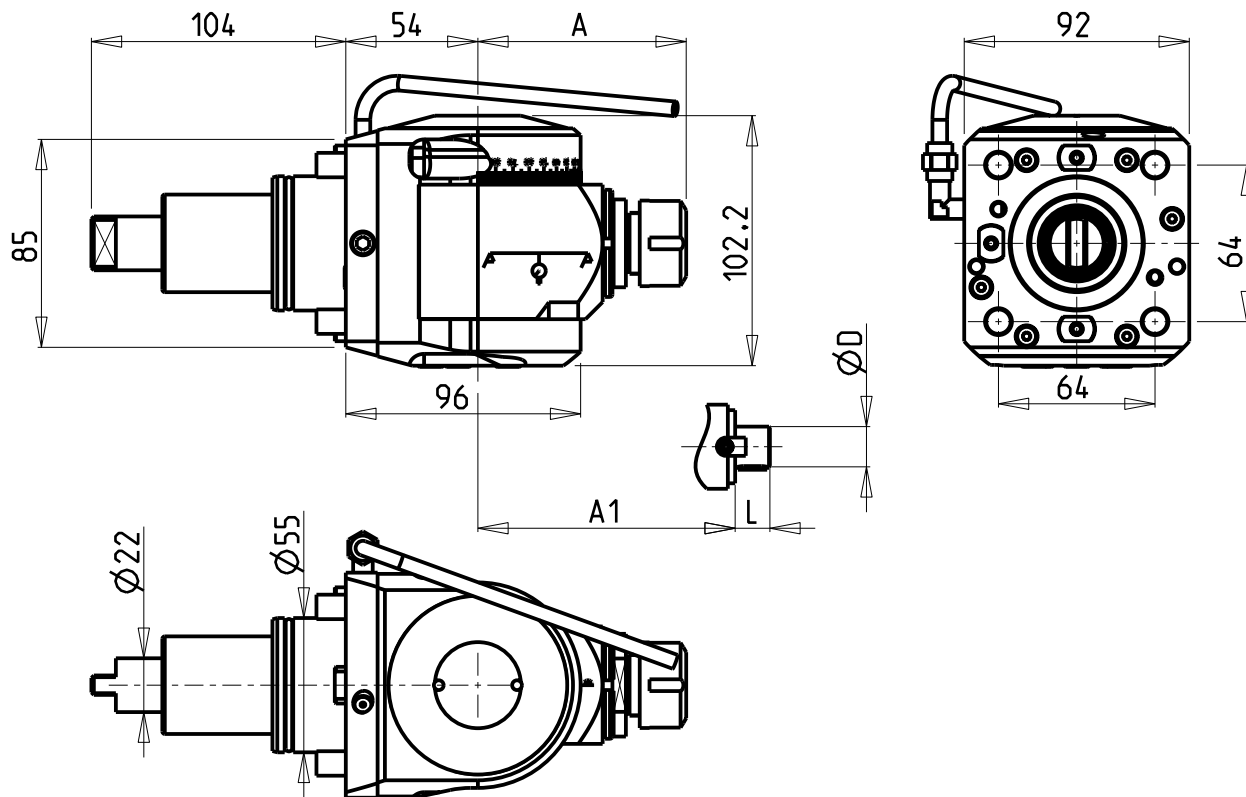
Subject to change without notice.

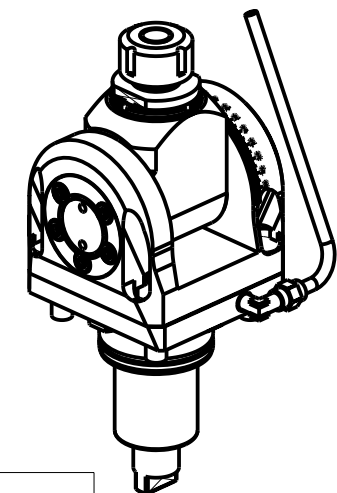

ATTENZIONE - ATTENTION - ACHTUNG

- VERIFICARE LE MISURE DI INGOMBRO PER POSSIBILE INTERFERENZA SU ALCUNI MODELLI DI MACCHINE
- Please check the overall sizes for possible interferences on some machine models
- Bitte überprüfen sie das ausmass um mögliche interferenzen auf einigen maschinen modellen zu vermeiden



Cod. MT	Mandrino Spindle Spindel	I	RPM	Coppia Max Max Torque Max Drehmoment	Reversibile lato mandrino/contromandrino Reversible sub/main spindle side Umkehrbare Spindelseite/ Gegenspindelseite	Lubrificazione est. Ext. coolant Aussehenkuehlung	A	A1	D	L	CHIAVI INCLUSE Keys included Schluessel inbegriffen		
											CH_VTCROCE_M08	CHUB36	CHESL08
DW 01910120	ER20	1:1	6000	40Nm	X	X	85.16	-	-	-	CHSTER20	CHUB36	CHESL08
DW 01910125	ER25	1:1	6000	40Nm	X	X	86.16	-	-	-	CHSTER25	CHUB36	CHESL08
DW 01910516	Ø16x17	1:1	6000	40Nm	X	X	-	65	16	17	CH_VTCROCE_M08	CHUB36	CHESL08
DW 01910522	Ø22x19	1:1	6000	40Nm	X	X	-	66	22	19	CH_VTCROCE_M10	CHUB36	CHESL08
DW 01910519	Ø3/4"x3/4"	1:1	6000	40Nm	X	X	-	65	3/4"	3/4"	CH_VTCROCE_M08	CHUB36	CHESL08

SAMSUNG
 MOD: PL240 LM - PL250 VM - SL1500/2000 M/Y/SY

MODULO MOTORIZZATO ORIENTABILE ±90°
 ±90° adjustable angle driven tool
 Angetriebenes Werkzeug schwenkbar ±90°

Subject to change without notice.

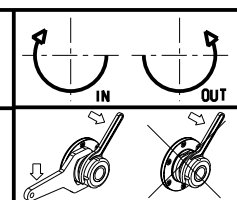

M.T. srl
 Via Casino Albini 480
 Tel. 0541/956034-957884
 Fax 0541/956341
 47842 S. GIOVANNI IN M. (RN)
 e-mail: mtma@mtmarchetti.com
 http://www.mtmarchetti.com

PRODUZIONE MODULI ROTANTI

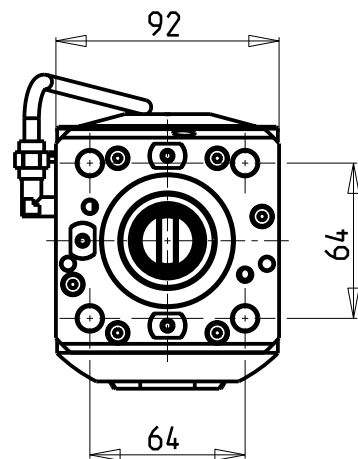
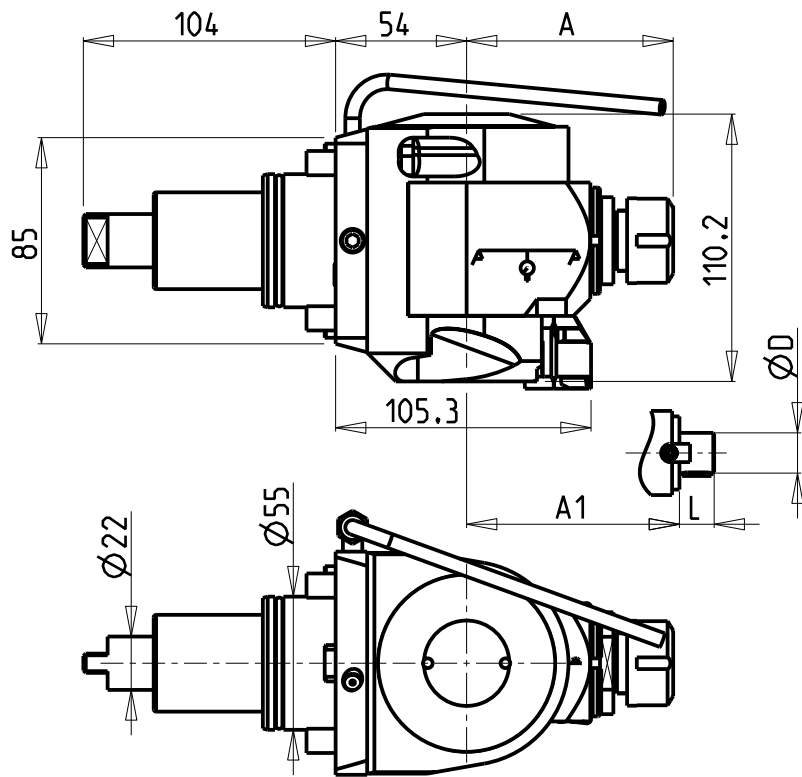
 PAGINA SMG333-5-00

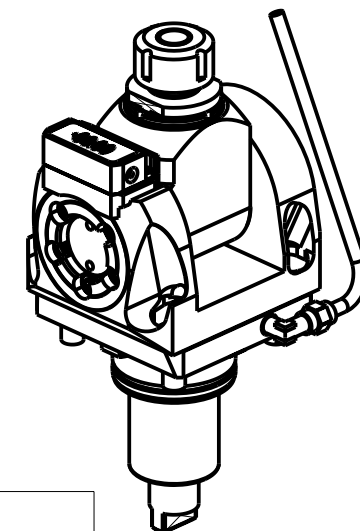

ATTENZIONE - ATTENTION - ACHTUNG

- VERIFICARE LE MISURE DI INGOMBRO PER POSSIBILE INTERFERENZA SU ALCUNI MODELLI DI MACCHINE
- Please check the overall sizes for possible interferences on some machine models
- Bitte überprüfen sie das ausmass um mögliche interferenzen auf einigen maschinen modellen zu vermeiden



Cod. MT	Mandrino Spindle Spindel	I	RPM	Coppia Max Max Torque Max Drehmoment	Reversibile lato mandrino/contromandrino Reversible sub/main spindle side Umkehrbare Spindelseite/ Gegenspindelseite	Lubrificazione est. Ext. coolant Ausseenkuehlung	A	A1	D	L	CHIAVI INCLUSE Keys included Schluessel inbegriffen		
											CH_VTCROCE_M08	CHUB36	CHESL08
DW 0184 0120	ER20	1:1	6000	40Nm	X	X	85.16	-	-	-	CHSTER20	CHUB36	CHESL08
DW 0184 0125	ER25	1:1	6000	40Nm	X	X	86.16	-	-	-	CHSTER25	CHUB36	CHESL08
DW 0184 0516	Ø16x17	1:1	6000	40Nm	X	X	-	65	16	17	CH_VTCROCE_M08	CHUB36	CHESL08
DW 0184 0522	Ø22x19	1:1	6000	40Nm	X	X	-	66	22	19	CH_VTCROCE_M10	CHUB36	CHESL08
DW 0184 0519	Ø3/4"x3/4"	1:1	6000	40Nm	X	X	-	65	3/4"	3/4"	CH_VTCROCE_M08	CHUB36	CHESL08

SAMSUNG
 MOD: PL240 LM - PL250 VM - SL1500/2000 M/Y/SY
 MODULO MOTORIZZATO ORIENTABILE ±90° CON NONIO DIGITALE
 ±90° adjustable angle driven tool with digital display
 Angetriebenes Werkzeug schwenkbar ±90° mit digital display
 Subject to change without notice.

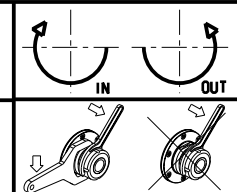

M.T. srl
 Via Casino Albini 480
 Tel. 0541/956034-957884
 Fax 0541/956341
 47842 S. GIOVANNI IN M. (RN)
 e-mail: mtma@mtmarchetti.com
 http://www.mtmarchetti.com

PRODUZIONE MODULI ROTANTI

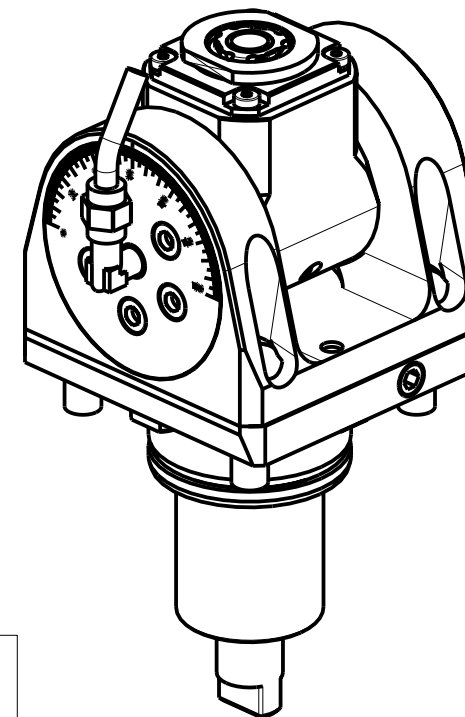
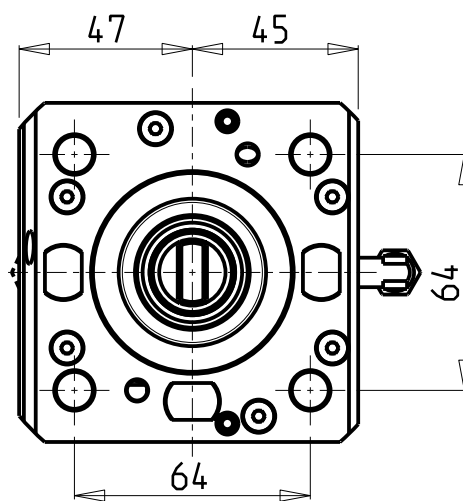
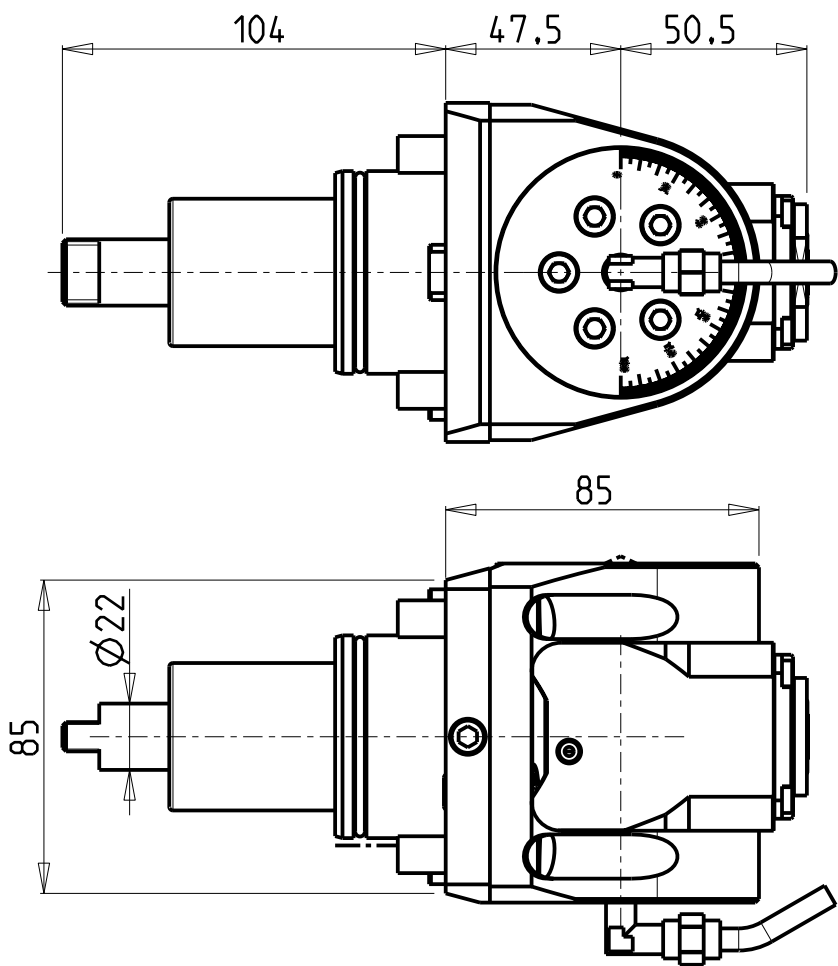
 PAGINA SMG333-5-01



Cod. MT	Mandrino Spindle Spindel	I	RPM	Coppia Max Max Torque Max Drehmoment	Lubrificazione int. Coolant through Innenkuehlung	Lubrificazione est. Ext. coolant Ausenkuehlung	CHIAVI INCLUSE Keys included Schluessel inbegriffen			
DW00660120	ERA20	1:1	6000	30Nm		X	CHUB22	CHUB36	CHTAER20ZC	CHESL07
DW00660220	ERA20	1:1	6000	30Nm	P=70bar	X	CHUB22	CHUB36	CHTAER20ZC	CHESL07

SAMSUNG

MOD: PL240 LM - PL250 VM - SL1500/2000 M/Y/SY

MODULO MOTORIZZATO ORIENTABILE ±90° H=47.5mm

±90° adjustable angle driven tool H=47.5mm

Angetriebenes Werkzeug schwenkbar ±90° H=47.5mm

Subject to change without notice.

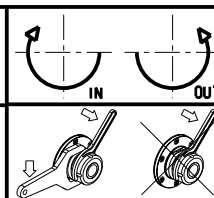

M.T. srl

Via Casino Albini 480
Tel. 0541/956034-957884
Fax 0541/956341

47842 S. GIOVANNI IN M. (RN)
e-mail: mtma@mtmarchetti.com
http://www.mtmarchetti.com

PRODUZIONE MODULI ROTANTI



PAGINA SMG335-5-00

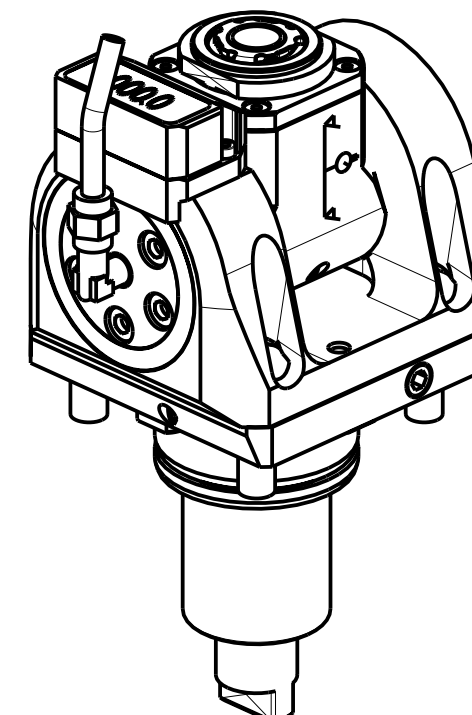
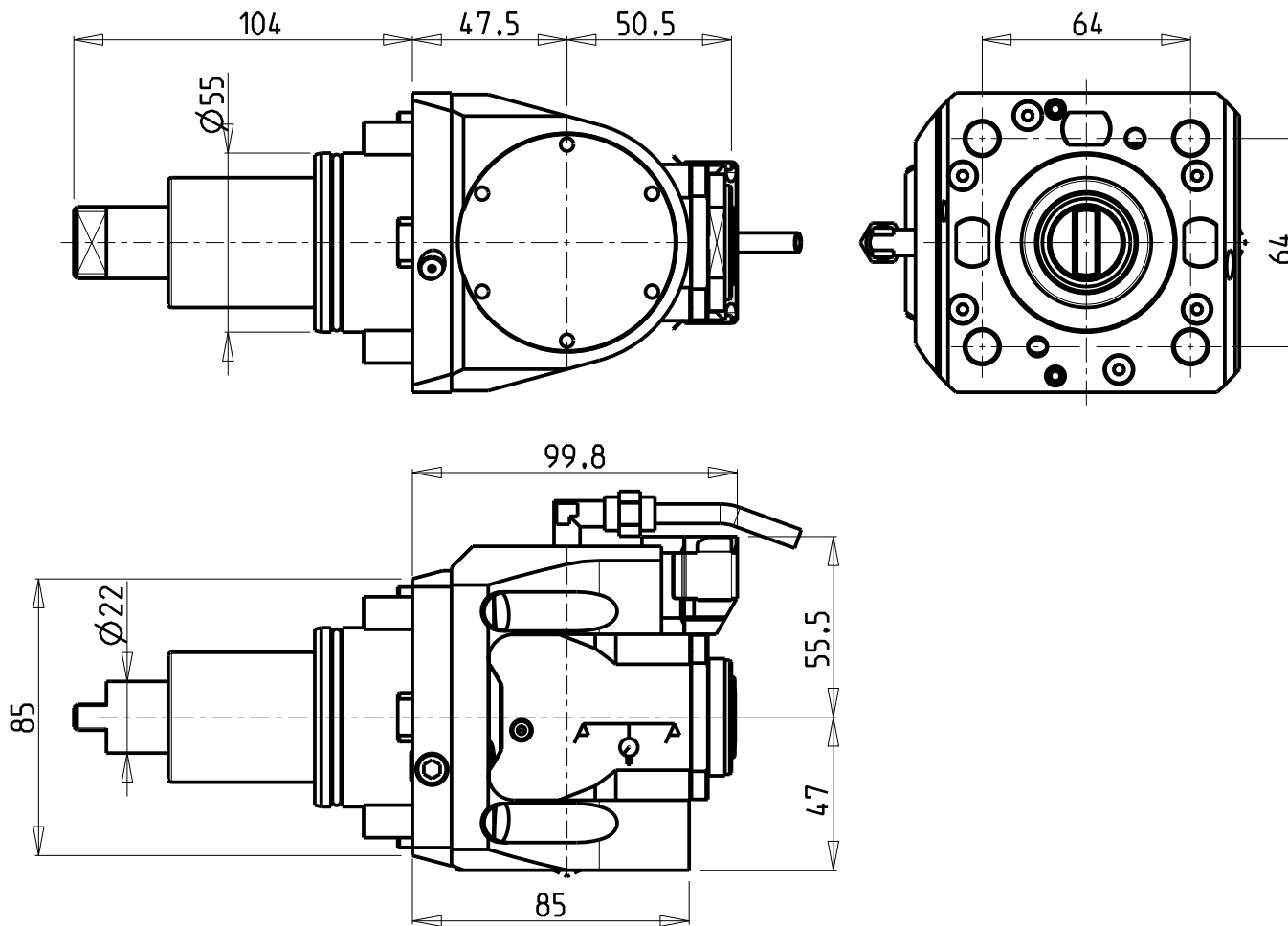

Cod. MT	Mandrino Spindle Spindel	I	RPM	Coppia Max Max Torque Max Drehmoment	Lubrificazione int. Coolant through Innenkuehlung	Lubrificazione est. Ext. coolant Ausenkuehlung	CHIAVI INCLUSE Keys included Schluessel inbegriffen			
							CHUB22	CHUB36	CHTAER20ZC	CHESL07
DW00665120	ERA20	1:1	6000	30Nm	-	X	CHUB22	CHUB36	CHTAER20ZC	CHESL07
DW00665220	ERA20	1:1	6000	30Nm	P=70bar	X	CHUB22	CHUB36	CHTAER20ZC	CHESL07

SAMSUNG
 MOD: PL240 LM - PL250 VM - SL1500/2000 M/Y/SY
 MODULO MOTORIZZATO ORIENTABILE ±90° CON NONIO DIGITALE H=47.5mm
 ±90° adjustable angle driven tool with digital display H=47.5mm
 Angetriebenes Werkzeug schwenkbar ±90° mit digital display H=47.5mm

Subject to change without notice.

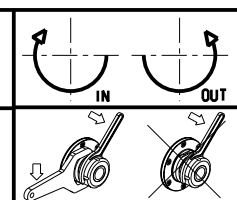

M.T. srl
 Via Casino Albini 480
 Tel. 0541/956034-957884
 Fax 0541/956341
 47842 S. GIOVANNI IN M. (RN)
 e-mail: mtma@mtmarchetti.com
 http://www.mtmarchetti.com

PRODUZIONE MODULI ROTANTI



PAGINA SMG335-5-01

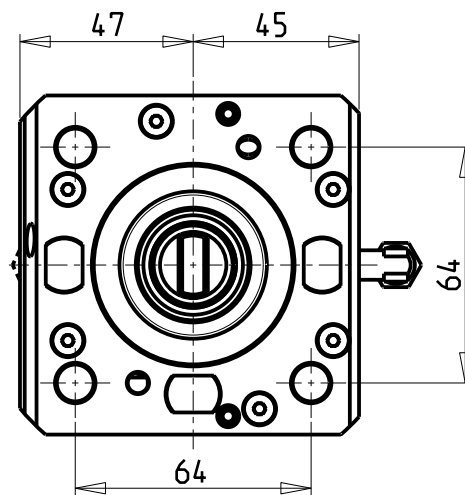
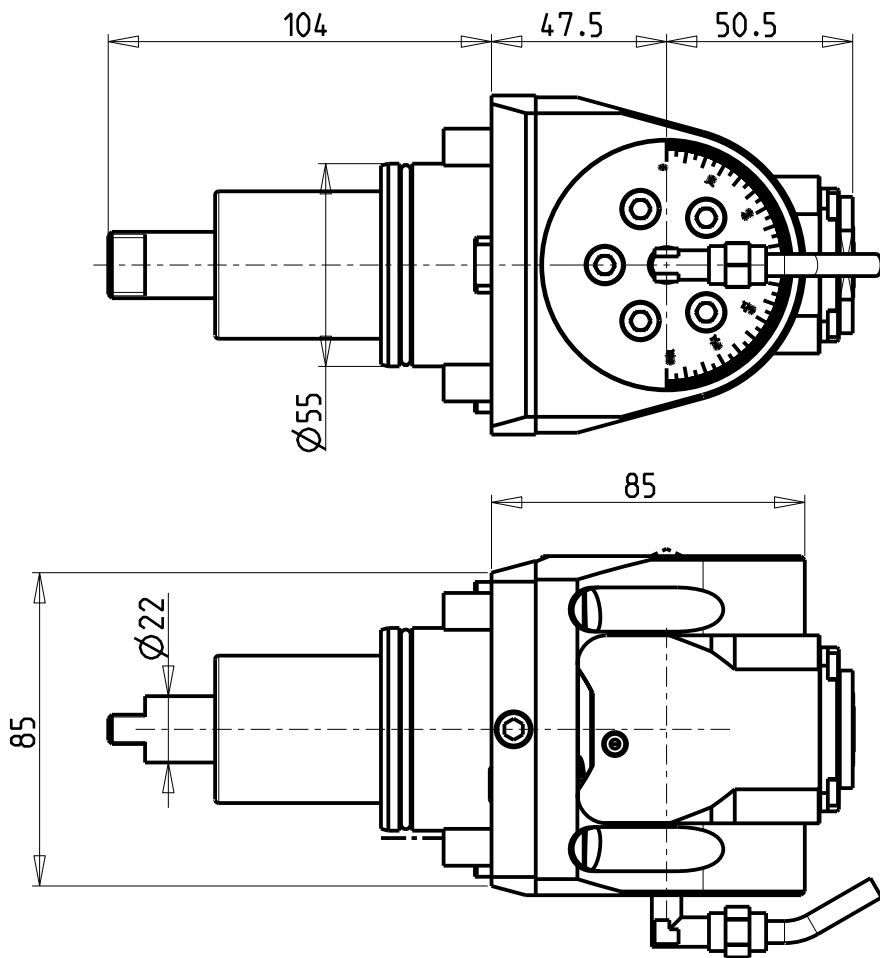

ATTENZIONE - ATTENTION - ACHTUNG

- Per lo smontaggio degli utensili utilizzare sempre la chiave di contrasto come indicato nel manuale d'uso.
- For disassembly of the tools use always the contrast key as mentioned in the user instructions.
- Fuer das Abmontieren der Werkzeuge immer den Gegenschlüssel benutzen wie in der Bedienungsanleitung erwaeht.

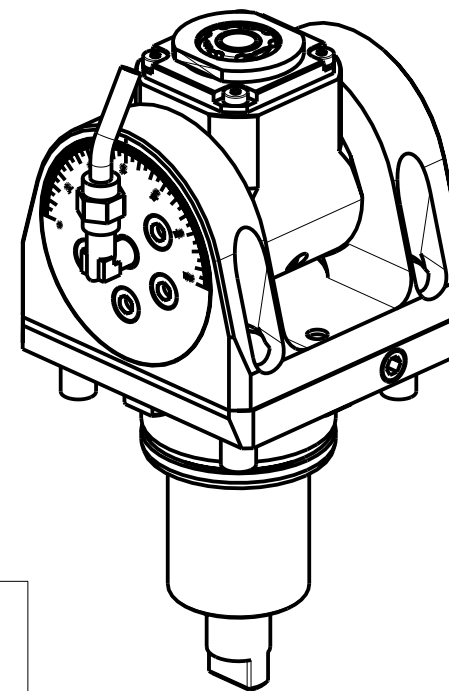

Cod. MT	Mandrino Spindle Spindel	I	RPM	Coppia Max Max Torque Max Drehmoment	Lubrificazione int. Coolant through Innenkuehlung	Lubrificazione est. Ext. coolant Aussenkuehlung	CHIAVI INCLUSE Keys included Schluesssel inbegriffen			
DW00660316	ERA16	1:2	12000	8Nm		X	CHUB19_SP3	CHUB32	CHTAER16ZC	CHESL07
DW00660416	ERA16	1:2	12000	8Nm	P=70bar	X	CHUB19_SP3	CHUB32	CHTAER16ZC	CHESL07

SAMSUNG
 MOD: PL240 LM - PL250 VM - SL1500/2000 M/Y/SY
 MODULO MOTORIZZATO ORIENTABILE +/-90° MOLTIPLICATO I=1:2 H=47.5mm
 +/-90° adjustable angle driven tool geared-up I=1:2 H=47.5mm
 Angetriebenes Werkzeug schwenkbar +/-90° uebersetzt I=1:2 H=47.5mm

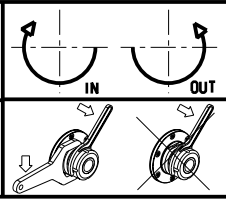

M.T. srl
 Via Casino Albini 480
 Tel. 0541/956034-957884
 Fax 0541/956341
 47842 S. GIOVANNI IN M. (RN)
 e-mail: mtma@mtmarchetti.com
 http://www.mtmarchetti.com

PRODUZIONE MODULI ROTANTI

 PAGINA SMG336-5-00

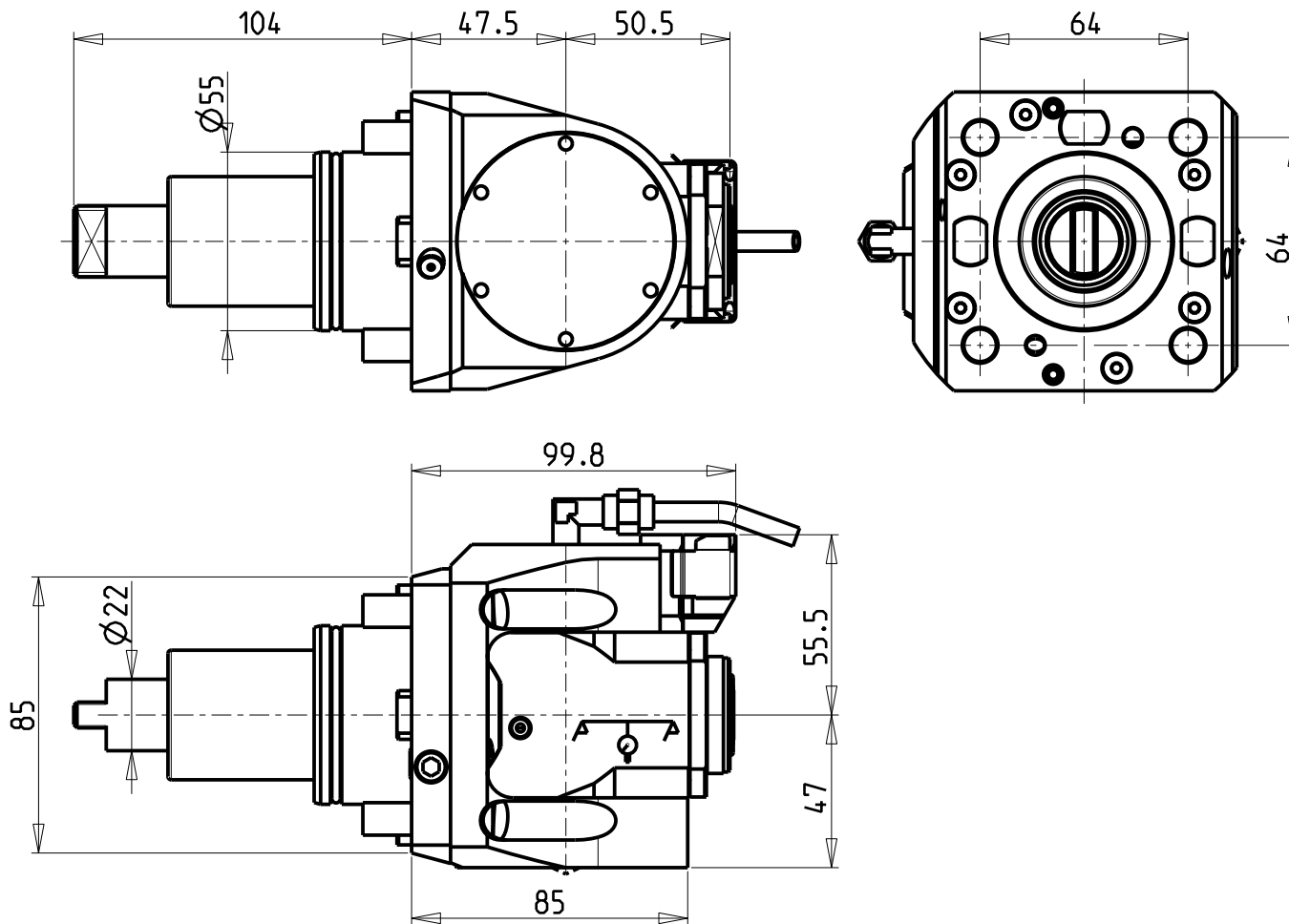
Subject to change without notice.

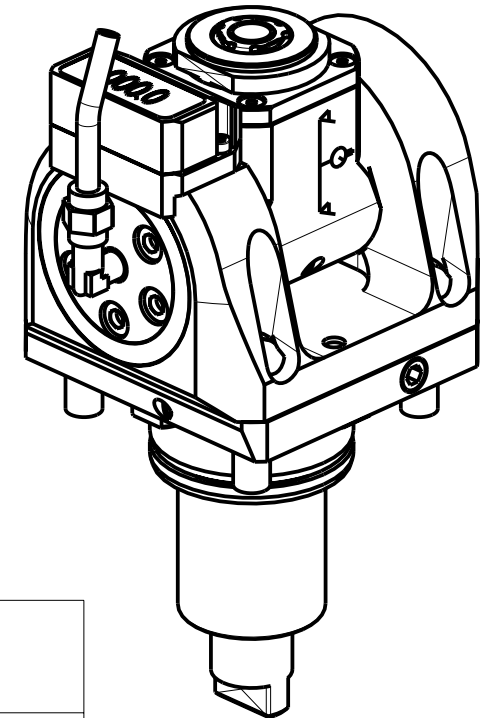

ATTENZIONE - ATTENTION - ACHTUNG

- Per lo smontaggio degli utensili utilizzare sempre la chiave di contrasto come indicato nel manuale d'uso.
- For disassembly of the tools use always the contrast key as mentioned in the user instructions.
- Fuer das Abmontieren der Werkzeuge immer den Gegenschlüssel benutzen wie in der Bedienungsanleitung erwaeht.



Cod. MT	Mandrino Spindle Spindel	I	RPM	Coppia Max Max Torque Max Drehmoment	Lubrificazione int. Coolant through Innenkuehlung	Lubrificazione est. Ext. coolant Aussenkuehlung	CHIAVI INCLUSE Keys included Schluessel inbegriffen			
DW00665316	ERA16	1:2	12000	8Nm	-	X	CHUB19_SP3	CHUB32	CHTAER16ZC	CHESL07
DW00665416	ERA16	1:2	12000	8Nm	P=70bar	X	CHUB19_SP3	CHUB32	CHTAER16ZC	CHESL07

SAMSUNG

MOD: PL240 LM - PL250 VM - SL1500/2000 M/Y/SY

MODULO MOTORIZZATO ORIENTABILE +/-90° MOLTIPLICATO I=1:2 CON NONIO DIGITALE H=47.5mm
 +/-90° adjustable angle driven tool geared-up I=1:2 with digital display H=47.5mm

Angetriebenes Werkzeug schwenkbar +/-90° uebersetzt I=1:2 mit digital display H=47.5mm

Subject to change without notice.

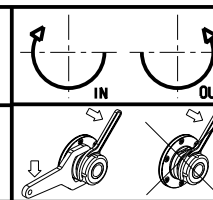

M.T. srl

Via Casino Albini 480
 Tel. 0541/956034-957884
 Fax 0541/956341
 47842 S. GIOVANNI IN M. (RN)
 e-mail: mtma@mtmarchetti.com
 http://www.mtmarchetti.com

PRODUZIONE MODULI ROTANTI



PAGINA SMG336-5-01

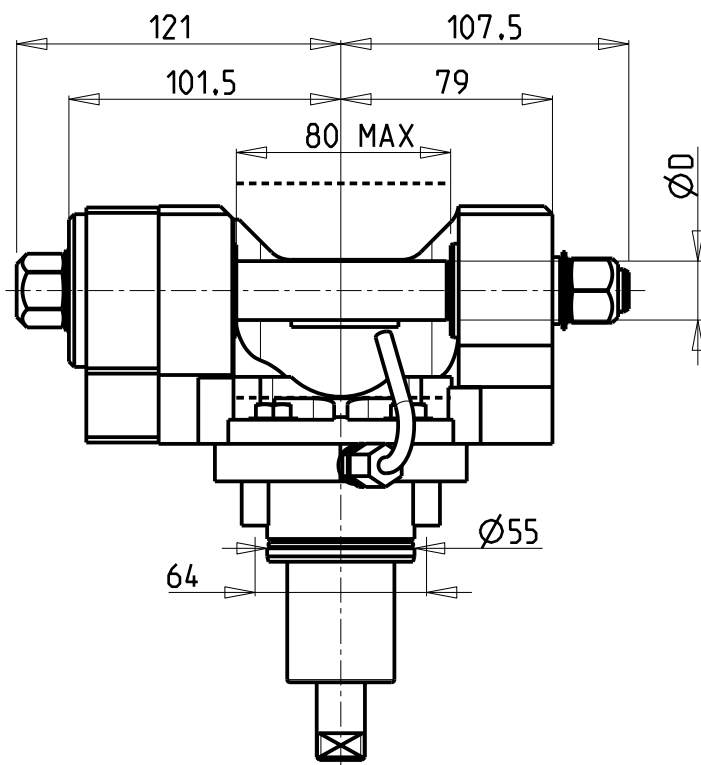
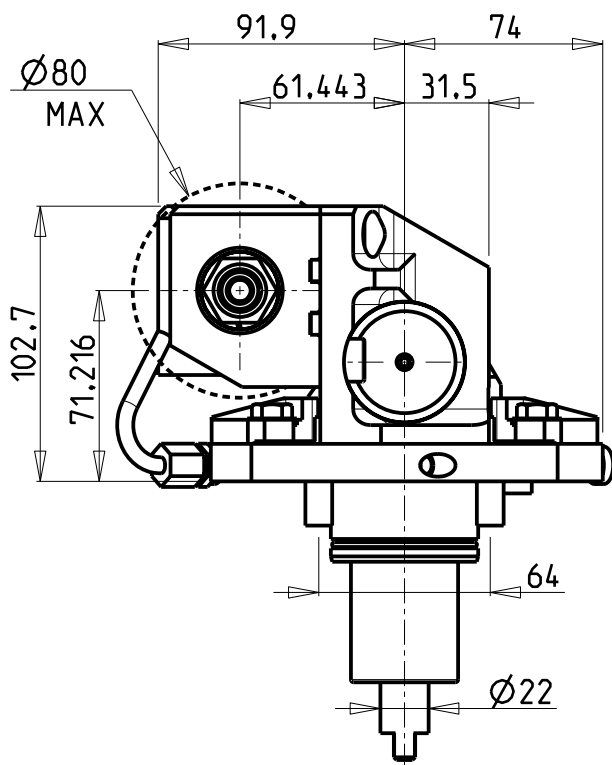

INCLINAZIONE
REGOLABILE ±20°

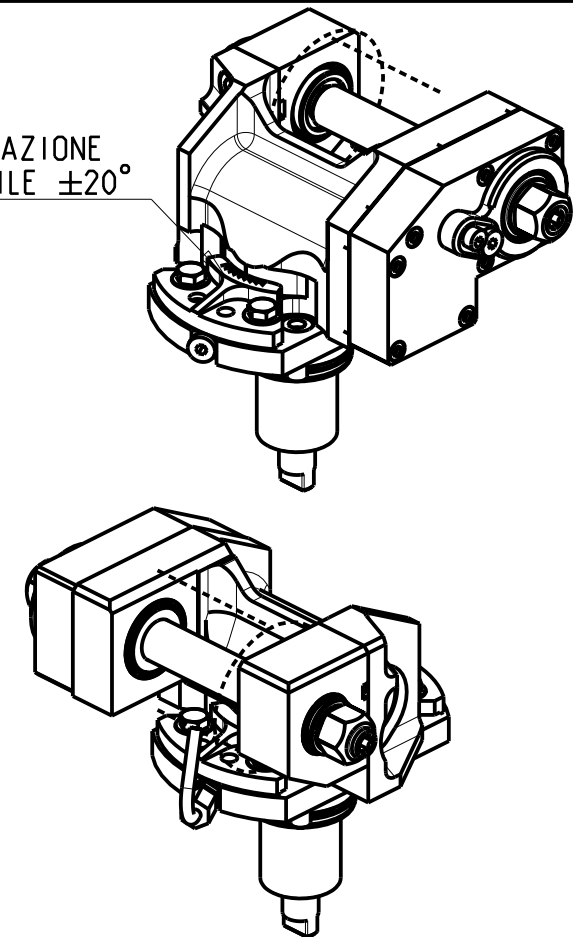

DOTAZIONI - SUPPLIED WITH - AUSSTATTUNG

mm / inch	- N°1 ALBERO + DISTANZIALI - N°1 SHAFT + SPACER - N°1 DORN + ABSTANDSSTUECK
-----------	---

PER ALBERI E DISTANZIALI VEDI PAG. TBL250-1-00
FOR SHAFT END SPACER SEE PAGE TBL250-1-00
FUER DORN UND ABSTANDSSTUECK SEITE TBL250-1-00

Cod. MT	I	RPM max	Coppia Max Max Torque Max Drehmoment	Reversibile lato mandrino/contromandrino Reversible sub/main spindle side Umkehrbare Spindel-seite/ Gegenspindel-seite	Lubrificazione est. Ext. coolant Aussenkuehlung	CHIAVI INCLUSE Keys included Schlüssel inbegriffen		
						D (mm)	D (Inch)	
0621100	1:1	6000	60Nm	X	X	16-22-27-32	3/4"-1"-1 1/4"	CHUB24 CHUB13 CHESL08
0622100	2:1	3000	80Nm	X	X	16-22-27-32	3/4"-1"-1 1/4"	CHUB24 CHUB13 CHESL08

ATTENZIONE - ATTENTION - ACHTUNG
- VERIFICARE LE MISURE DI INGOMBRO PER POSSIBILE INTERFERENZA SU ALCUNI MODELLI DI MACCHINE
- Please check the overall sizes for possible interferences on some machine models
- Bitte überprüfen sie das ausmass um mögliche interferenzen auf einigen maschinen modellen zu vermeiden

SAMSUNG
MOD: PL240 LM - SL1500/2000 M/Y/SY

MODULO MOTORIZZATO PORTACREATORE
Driven gear hobber
Angetriebenes Zahnradwaeltzraes-Werkzeug

Subject to change without notice.

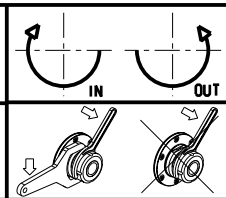

M.T. srl
Via Casino Albini 480
Tel. 0541/956034-957884
Fax 0541/956341
47842 S. GIOVANNI IN M. (RN)
e-mail: mtma@tmarchetti.com
http://www.tmmarchetti.com

PRODUZIONE MODULI ROTANTI



PAGINA SMG340-5-00

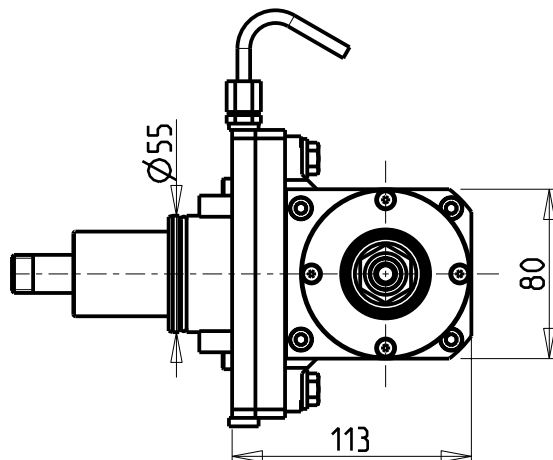
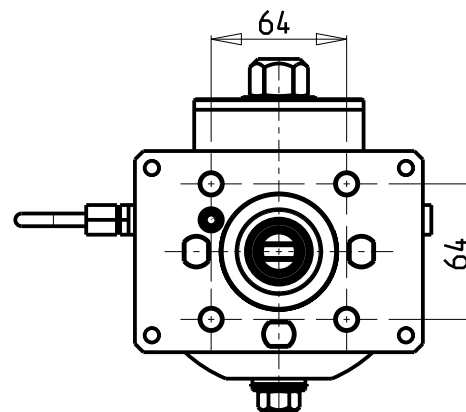
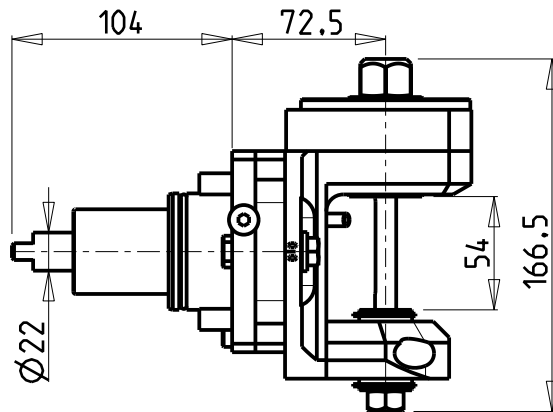
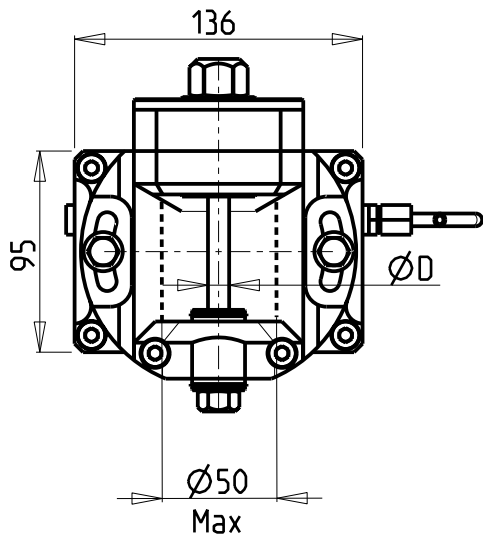

ATTENZIONE - ATTENTION - ACHTUNG

- VERIFICARE LE MISURE DI INGOMBRO PER POSSIBILE INTERFERENZA SU ALCUNI MODELLI DI MACCHINE
- Please check the overall sizes for possible interferences on some machine models
- Bitte überprüfen sie das ausmass um mögliche interferenzen auf einigen maschinen modellen zu vermeiden

INCLINAZIONE
REGOLABILE ±15°

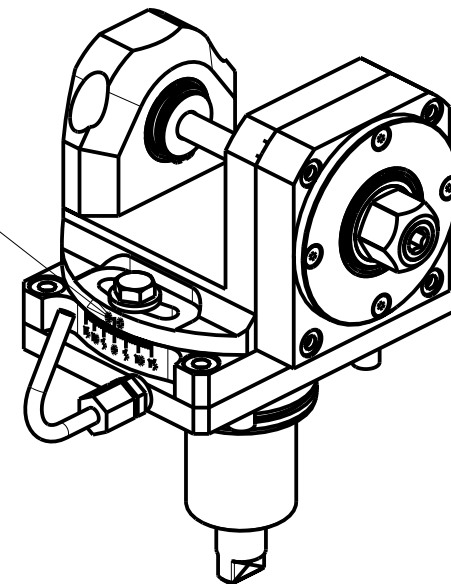

Cod. MT	I	RPM max	Coppia Max Max Torque Max Drehmoment	Lubrificazione est. Ext. coolant Aussenkuehlung	D (mm)	CHIAVI INCLUSE Keys included Schluessel inbegriffen					
DW 00051108	1:1	6000	50Nm	X	8	CHUB24	CHUB13	CHESL08	CHESL06	CHESL04	
DW 00051110	1:1	6000	50Nm	X	10	CHUB24	CHUB17	CHUB13	CHESL08	CHESL06	CHESL05
DW 00051113	1:1	6000	50Nm	X	13	CHUB24	CHUB19	CHUB13	CHESL08	CHESL06	
DW 00051116	1:1	6000	50Nm	X	16	CHUB24	CHUB13	CHESL08	CHESL06		

SAMSUNG

MOD: PL240 LM - SL1500/2000 M/Y/SY

MODULO MOTORIZZATO PORTACREATORE RADIALE

Radial driven gear hobber

Radial Angetriebenes Zahnradwaelzfraes-Werkzeug

Subject to change without notice.

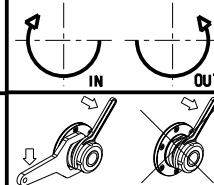

M.T. srl

Via Casino Albini 480
Tel. 0541/956034-957884

Fax 0541/956341

47842 S. GIOVANNI IN M. (RN)

e-mail: mtma@mtmarchetti.com

http://www.mtmarchetti.com

PRODUZIONE MODULI ROTANTI



PAGINA SMG340-5-30

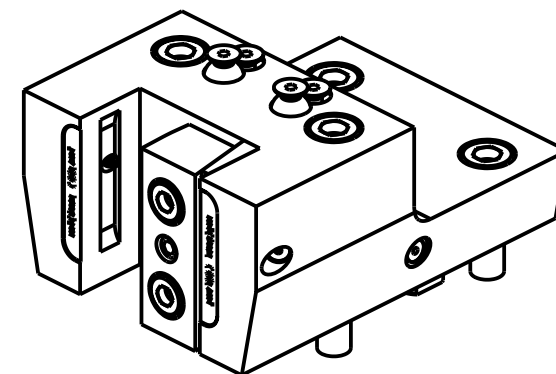
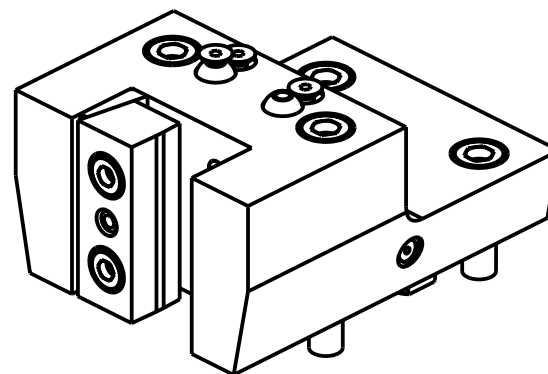
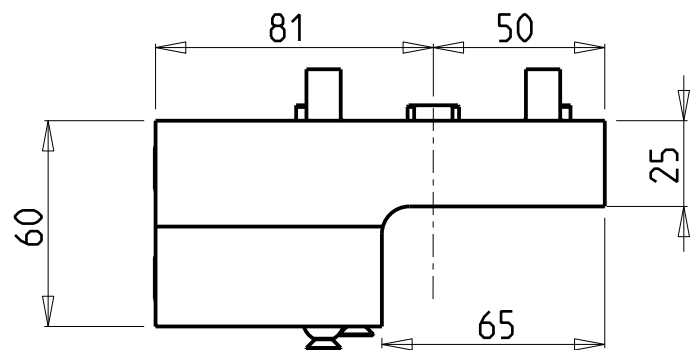
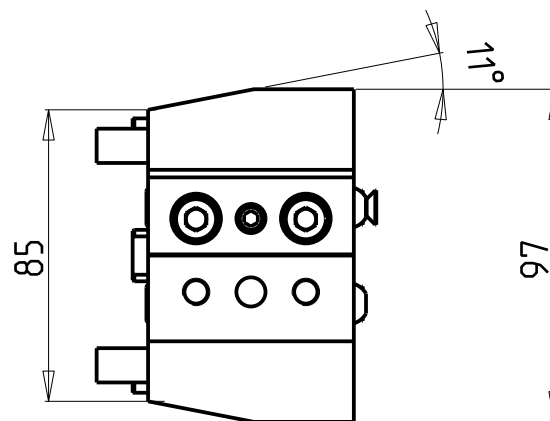
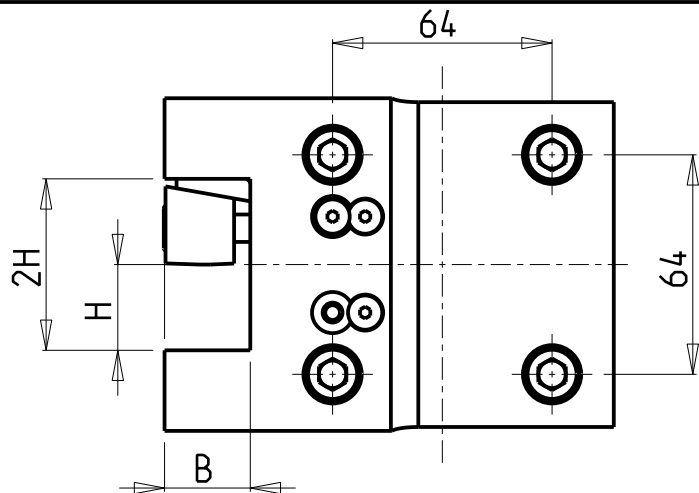

DW 02222510

Cod. MT	N°Utensili N°Tools N°Werkzeuge	Reversibile lato mandrino/contromandrino Reversible sub/main spindle side Umkehrbare Spindel-seite/ Gegenspindel-seite	Lubrificazione int. Coolant through Innenkuehlung	Lubrificazione est. Ext. coolant Aussenkuehlung	Misure Dimensions Masse	B	H
DW02222500	1	X	-	X	mm	25	25
DW02222540	1	X	-	X	Inch	1"	1"
DW02222510	1	X	P=70bar	X	mm	25	25

NEW

SAMSUNG

MOD: PL240 LM - PL250 VM - SL1500/2000 M/Y/SY

PORTAUTENSILE RADIALE SINGOLO QD=25mm / QD=1"

Radial single static tool QD=25mm / QD=1"

Radial Single-Werkzeughalter QD=25mm / QD=1"

Subject to change without notice.

M.T. srl

Via Casino Albini 480
Tel. 0541/956034-957884
Fax 0541/956341
47842 S. GIOVANNI IN M. (RN)
e-mail: mtma@mtmarchetti.com
http://www.mtmarchetti.com

PRODUZIONE MODULI ROTANTI



PAGINA SMG423-5-00

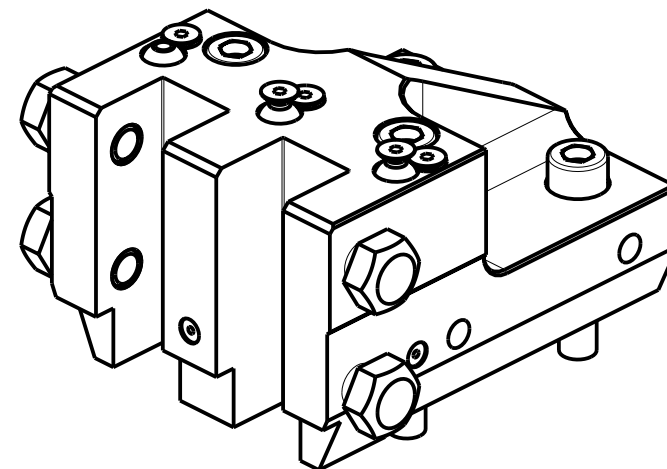
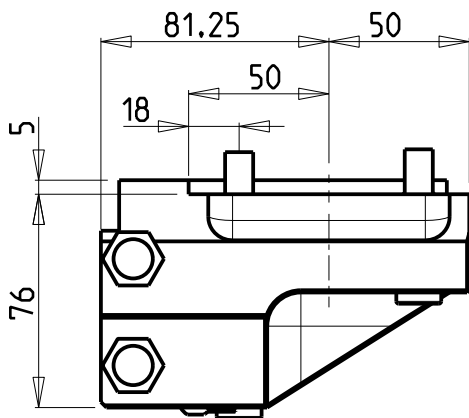
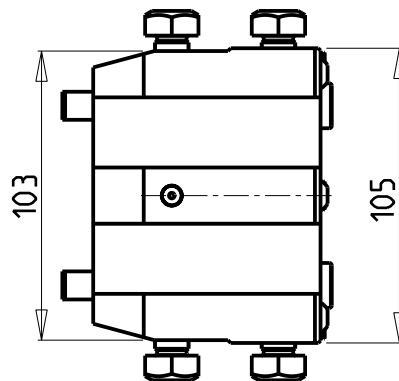
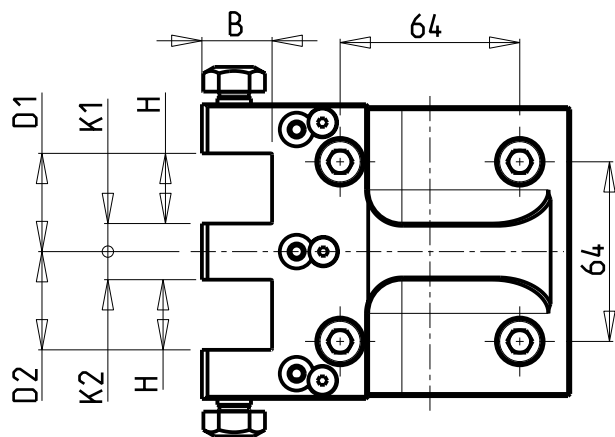

Cod. MT	N°Utensili N°Tools N°Werkzeuge	Reversibile lato mandrino/contromandrino Reversible sub/main spindle side Umkehrbare Spindelseite/ Gegenspindelseite	Misure Dimensions Masse	H	B	K1	K2	D1	D2
0772500	2	X	mm	25	25	10	10	35	35
0772540	2	X	inch	1"	1"	3/8"	3/8"	1 3/8"	1 3/8"

SAMSUNG

MOD: SL1500/2000 Y/SY

PORTAUTENSILE RADIALE SOVRAPPOSTO QD=25mm / QD=1"

Radial single side twin static tool QD=25mm / QD=1"

Radial Werkzeughalter ueberlagert QD=25mm / QD=1"

Subject to change without notice.

M.T. srl

Via Casino Albini 480
Tel. 0541/956034-957884
Fax 0541/956341
47842 S. GIOVANNI IN M. (RN)
e-mail: mtma@mtmarchetti.com
http://www.mtmarchetti.com

PRODUZIONE MODULI ROTANTI



PAGINA SMG442-5-00

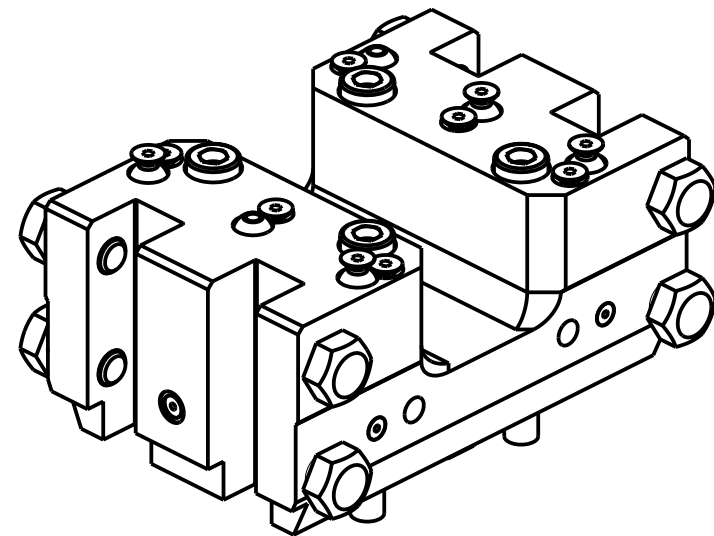
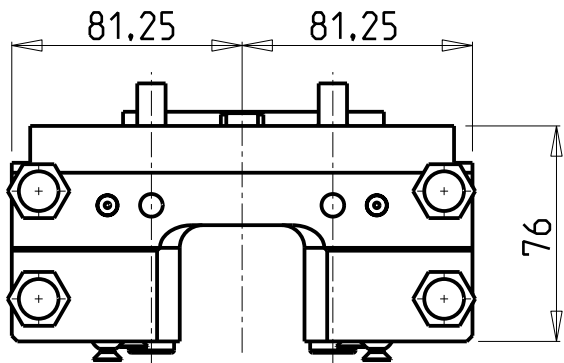
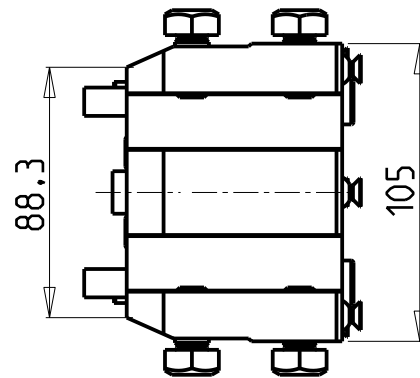
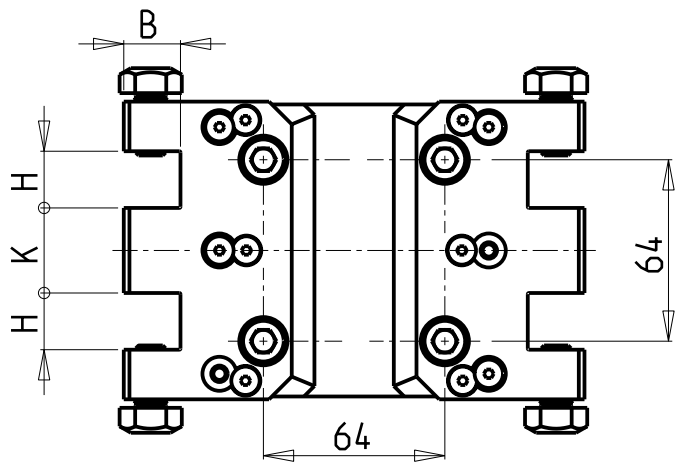

Cod. MT	N°Utensili N°Tools N°Werkzeuge	Reversibile lato mandrino/contromandrino Reversible sub/main spindle side Umkehrbare Spindel-seite/ Gegenspindel-seite	Misure Dimensions Masse	H	K	B
0762000	4	X	mm	20	30	20
0761905	4	X	inch	3/4"	1 1/4"	3/4"
0762500	4	X	mm	25	20	25
0762540	4	X	inch	1"	3/4"	1"

SAMSUNG
MOD: SL1500/2000 Y/SY

PORTAUTENSILE RADIALE DOPPIO SOVRAPPOSTO QD=20mm / QD=3/4" / QD=25mm / QD=1"
Radial double side twin static tool QD=20mm / QD=3/4" / QD=25mm / QD=1"
Radial Doppel-Werkzeughalter ueberlagert QD=20mm / QD=3/4" / QD=25mm / QD=1"

Subject to change without notice.

M.T. srl
Via Casino Albini 480
Tel. 0541/956034-957884
Fax 0541/956341
47842 S. GIOVANNI IN M. (RN)
e-mail: mtma@mtmarchetti.com
http://www.mtmarchetti.com

PRODUZIONE MODULI ROTANTI

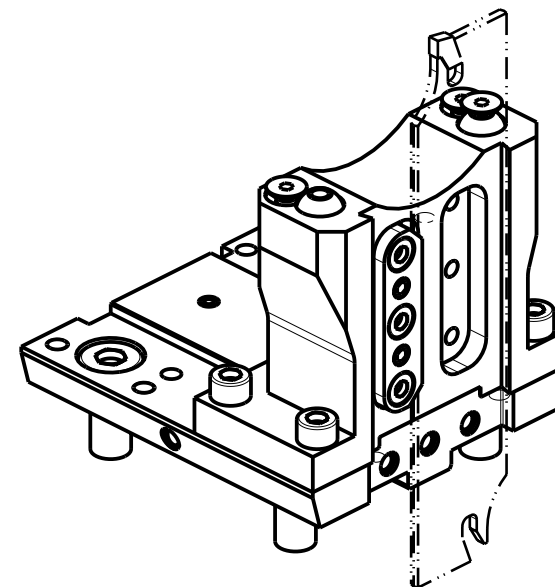
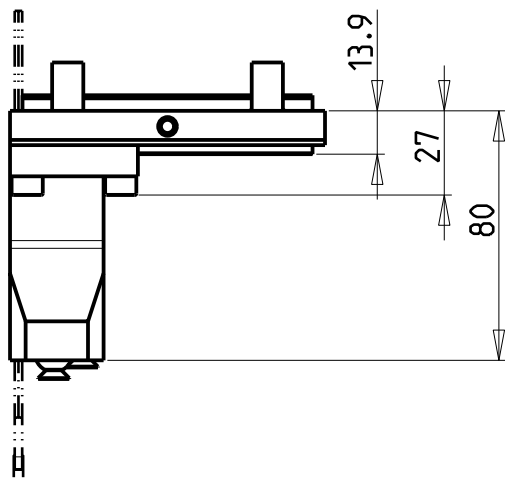
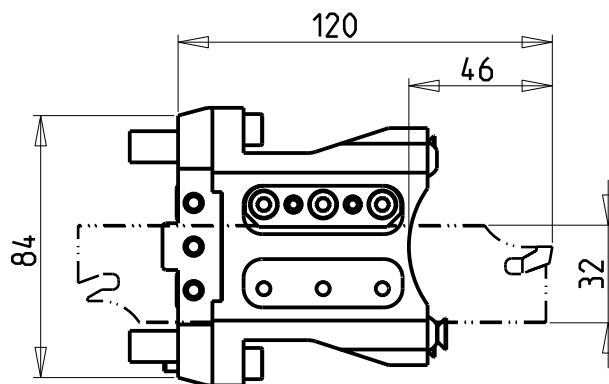
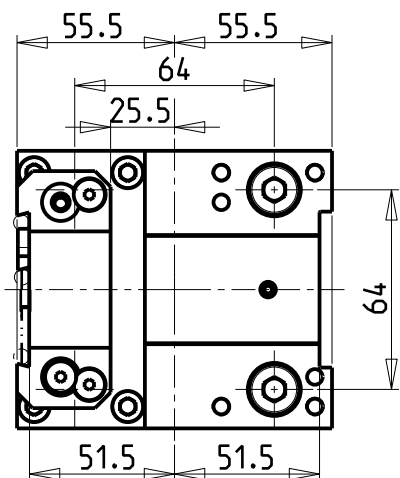
PAGINA SMG463-5-00



POSSIBILITA' DI LAVORO M3/M4
 OPTION OF M3/M4 WORKING
 ARBEITSMÖGLICHKEIT M3/M4

DOTAZIONI - SUPPLIED WITH - AUSSTATTUNG

N°1 - LAMA - BLADE - KLINGE ISCAR H=32 Sp. 3/4mm
 (KENNAMETAL OPTIONAL)

N°10 - INSERTI - INSERTS - EINLAGEN

N°1 - CHIAVE A T PER MONTAGGIO INSERTI
 - T-WRENCH FOR INSERT SET UP
 - T-SCHLUESSEL FUER EINSATZSTUECK-MONTAGE

Cod. MT	N°Utensili N°Tools N°Werkzeuge	Reversibile lato mandrino/contromandrino Reversible sub/main spindle side Umkehrbare Spindel-seite/ Gegenspindel-seite	Lubr.esterna Ext. coolant Aussehenkuehlung
DW02380132	1	X	X

SAMSUNG

MOD: PL240 LM - PL250 VM - SL1500/2000 M/Y/SY

PORTAUTENSILE RADIALE PER LAMA

Radial blade holder

Radial Abstechhalter

Subject to change without notice.

M.T. srl

Via Casino Albini 480
 Tel. 0541/956034-957884
 Fax 0541/956341
 47842 S. GIOVANNI IN M. (RN)
 e-mail: mtma@mtmarchetti.com
 http://www.mtmarchetti.com

PRODUZIONE MODULI ROTANTI



PAGINA SMG520-5-01

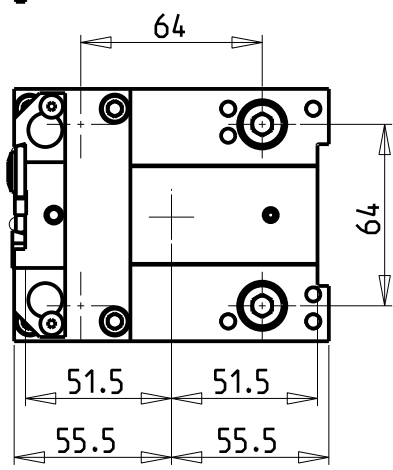
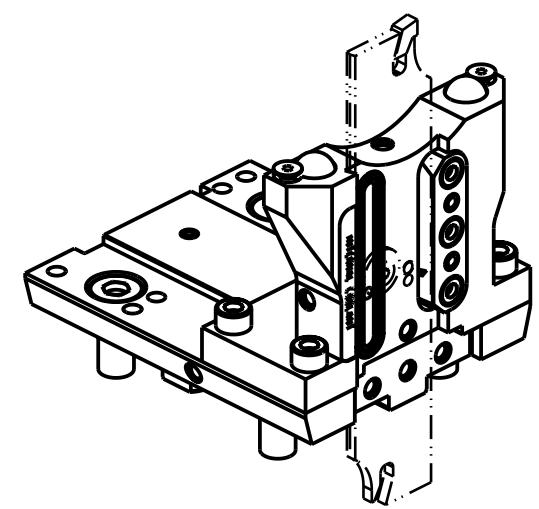
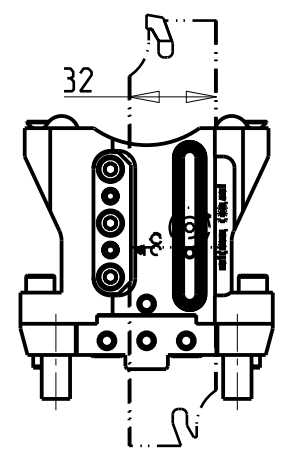
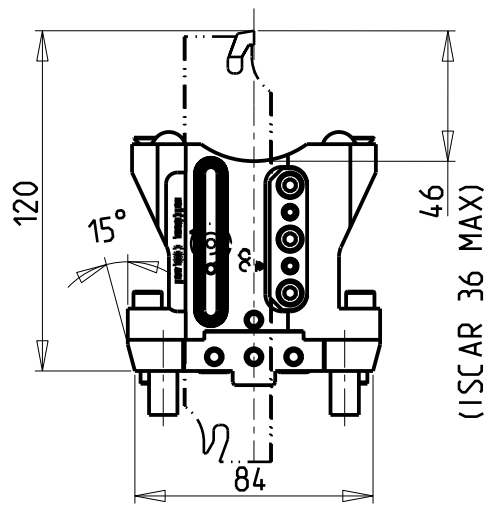
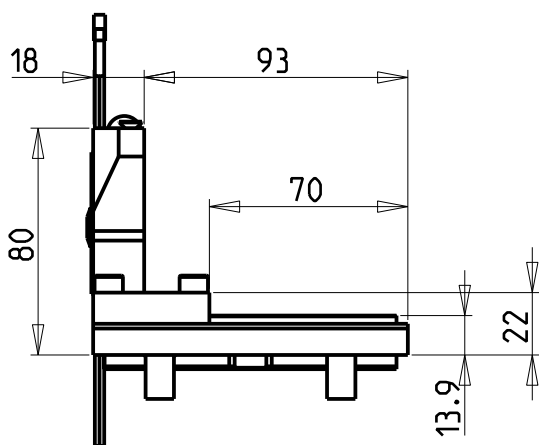

versione dx
right version
version rechts

versione sx
left version
version links

**KIT LAME NON INCLUSI (OPZIONALI)
BLADES NOT SUPPLIED WITH (OPTIONAL)
KLINGEN NICHT INBEGRIFFEN (OPTIONAL)**

- LAMA-BLADE-KLINGE SANDVIK H=32 sp.3 cod. QD_NN2G60C25A
+INSERTI-INSERTS-EINLAGEN cod. QD_NG_0300_0002_CM_1145 (10 pz.)
- LAMA-BLADE-KLINGE SANDVIK H=32 sp.4 cod. QD_NN2H60C25A
+INSERTI-INSERTS-EINLAGEN cod. QD_NH_0400_0002_CM_1145 (10 pz.)
- LAMA-BLADE-KLINGE ISCAR H=32 sp.3 cod. SGFH_32K_3
+INSERTI-INSERTS-EINLAGEN cod. 6011365 (10pz.)
- LAMA-BLADE-KLINGE ISCAR H=32 sp.4 cod. SGFH_32K_4
+INSERTI-INSERTS-EINLAGEN cod. 6011366 (10pz.)
- LAMA-BLADE-KLINGE WALTER H=32 sp.3 cod. G2042.32N-3T45SX-P
+INSERTI-INSERTS-EINLAGEN cod. SX-3E300N02-CE4 WSM33S (10pz.) + CHIAVE-KEY cod. FS1494
- LAMA-BLADE-KLINGE WALTER H=32 sp.4 cod. G2042.32N-4T50SX-P
+INSERTI-INSERTS-EINLAGEN cod. SX-4E400N02-CE4 WSM33S (10pz.) + CHIAVE-KEY cod. FS1494

Cod. MT		N°Utensili N°Tools N°Werkzeuge	Reversibile lato mandrino/contromandrino Reversible sub/main spindle side Umkehrbare Spindel-seite/ Gegenspindel-seite	Lubr.esterna Ext. coolant Aussenkuehlung	Lubr.interna Coolant through Innenkuehlung
versione dx right version version rechts	versione sx left version version links				
DW 02390132R	DW 02390132L	1	X	X	P=70bar

SAMSUNG

MOD: PL240 LM - PL250 VM - SL1500/2000 M/Y/SY

PORTAUTENSILE RADIALE PER LAMA CON LUBRIFICAZIONE INTERNA

Radial blade holder with internal coolant

Radial Abstechhalter mit Innenkuehlung

Subject to change without notice.

M.T. srl
Via Casino Albini 480
Tel. 0541/956034-957884
Fax 0541/956341
47842 S. GIOVANNI IN M. (RN)
e-mail: mtma@mtmarchetti.com
http://www.mtmarchetti.com

PRODUZIONE MODULI ROTANTI



PAGINA SMG520-5-05

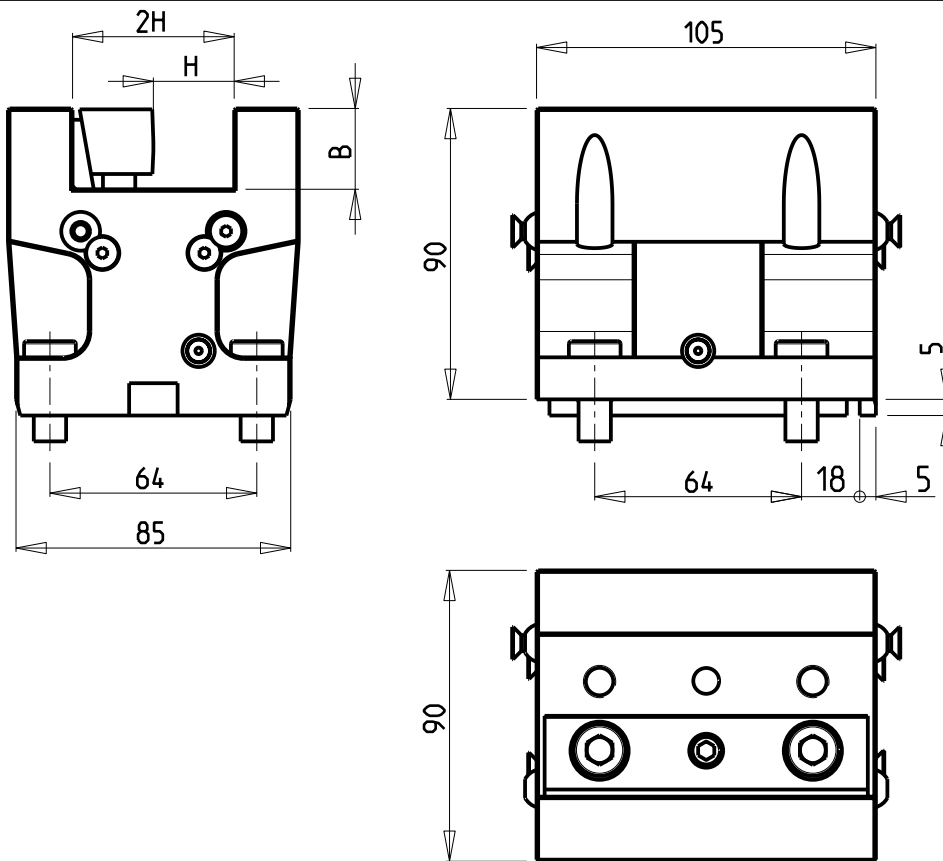

DW 004 22510

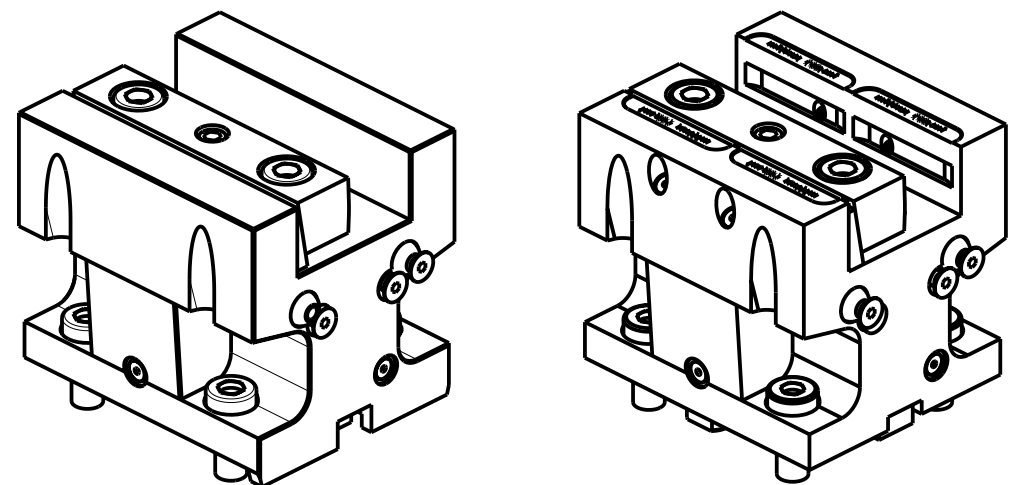

Cod. MT	N°Utensili N°Tools N°Werkzeuge	Reversibile lato mandrino/contromandrino Reversible sub/main spindle side Umkehrbare Spindel-seite/ Gegenspindel-seite	Lubrificazione int. Coolant through Innenkuehlung	Lubrificazione est. Ext. coolant Aussenkuehlung	Misure Dimensions Masse	B	H
DW 004 22500	1	X	-	X	mm	25	25
DW 004 22540	1	X	-	X	Inch	1"	1"
DW 004 22510	1	X	P=70bar	X	mm	25	25

NEW

SAMSUNG

MOD: PL240 LM - PL250 VM - SL1500/2000 M/Y/SY

PORTAUTENSILE ASSIALE SINGOLO QD=25mm / QD=1"

Axial single static tool QD=25mm / QD=1"

Axial Single-Werkzeughalter QD=25mm / QD=1"

Subject to change without notice.

M.T. srl
Via Casino Albini 480
Tel. 0541/956034-957884
Fax 0541/956341
47842 S. GIOVANNI IN M. (RN)
e-mail: mtma@mtmarchetti.com
http://www.mtmarchetti.com

PRODUZIONE MODULI ROTANTI



PAGINA SMG552-5-00

PER BOCCOLE DI RIDUZIONE VEDI PAG. TBL150-1-00
 FOR REDUCING BUSHINGS SEE PAGE TBL150-1-00
 FÜR REDUZIERBUCHSE SIEHE SEITE TBL150-1-00

KIT ADDUZIONE INTERNA (OPZIONALE)
 KIT FOR INTERNAL COOLANT (OPTIONAL)
 KIT FUER INTERNE KUEHLMITTELZUFUHR (OPTIONAL)
 Ø50-Ø2" cod. KIT1000002

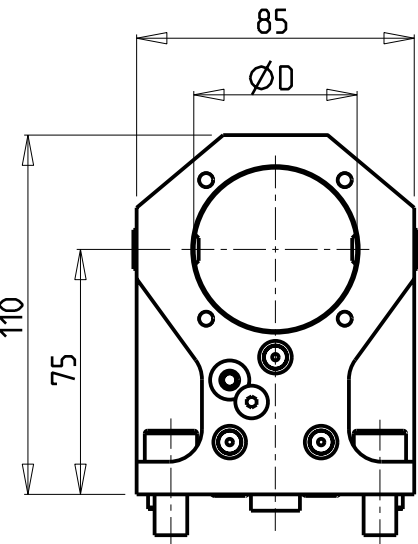
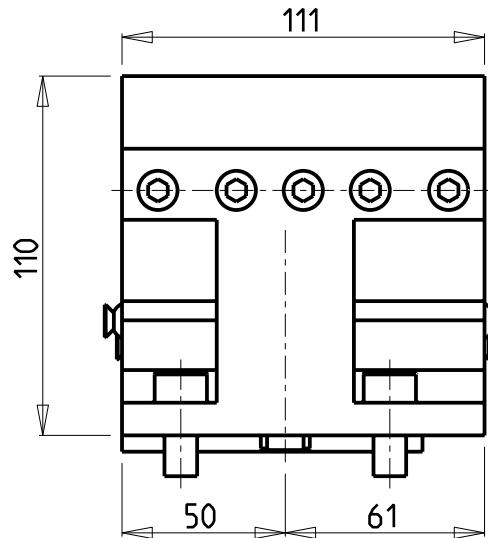
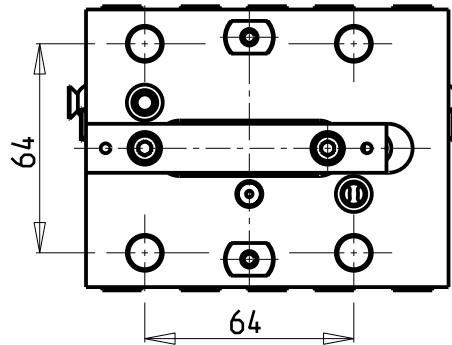
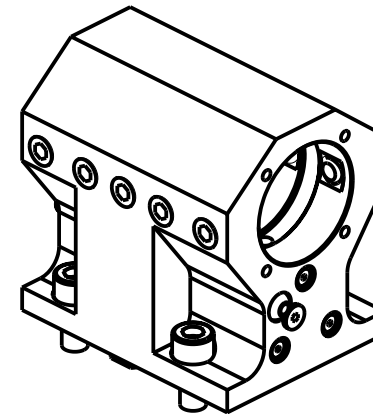
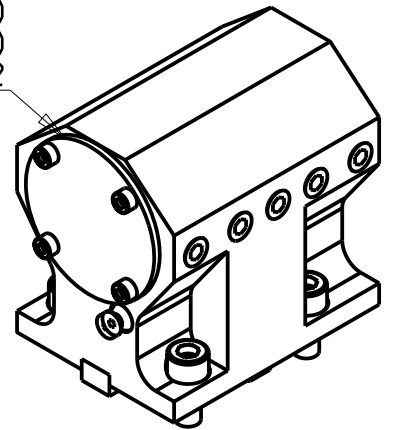

Cod. MT	Reversibile lato mandrino/contromandrino Reversible sub/main spindle side Umkehrbare Spindel-seite/ Gegenspindel-seite	Lubrificazione int. opzionale Coolant through optional Innenkuehlung Optional	Lubrificazione est. Ext. coolant Aussenkuehlung	Misure Dimensions Masse	D
DW02355000	X	X	X	mm	50
DW02355080	X	X	X	Inch	2"

SAMSUNG
 MOD: PL240 LM - PL250 VM - SL1500/2000 M/Y/SY
 PORTAUTENSILE ASSIALE PER BARENO Ø50mm / Ø2" H=75mm
 Axial single boring bar holder Ø50mm / Ø2" H=75mm
 Axial Bohrhälter Ø50mm / Ø2" H=75mm

M.T. srl
 Via Casino Albini 480
 Tel. 0541/956034-957884
 Fax 0541/956341
 47842 S. GIOVANNI IN M. (RN)
 e-mail: mtma@mtmarchetti.com
 http://www.mtmarchetti.com

PRODUZIONE MODULI ROTANTI

 PAGINA SMG610-5-10

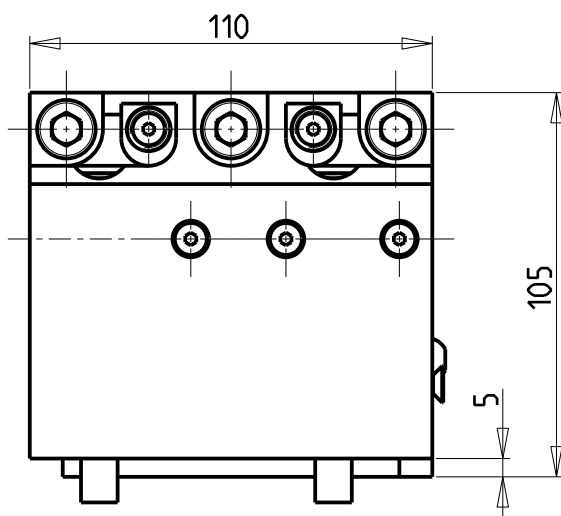
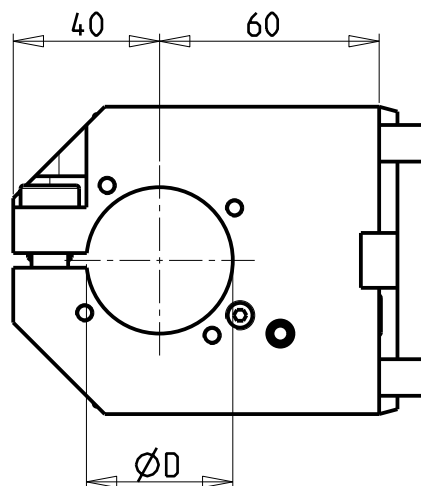
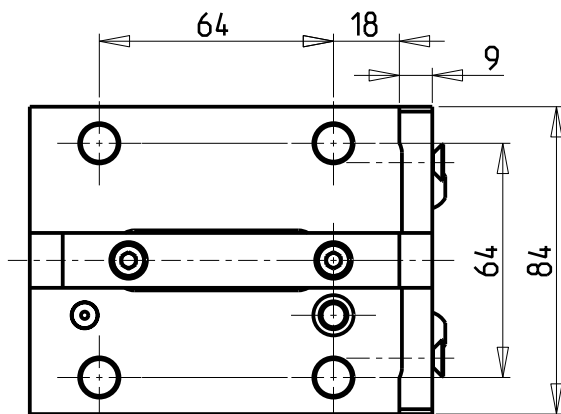
Subject to change without notice.

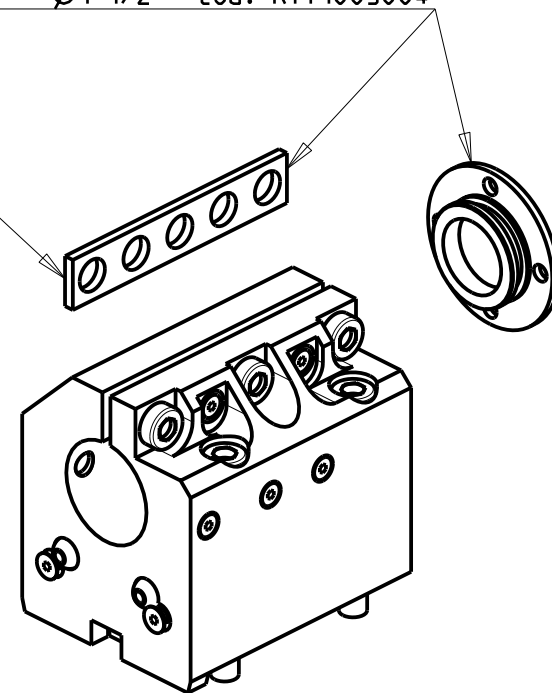

KIT ADDUZIONE INTERNA (OPZIONALE)
 KIT FOR INTERNAL COOLANT (OPTIONAL)
 KIT FUER INTERNE KUEHLMITTELZUFUHR (OPTIONAL)
 Ø40 cod. KIT1003003
 Ø1 1/2" cod. KIT1003004

SOLO GUARNIZIONE (OPZIONALE)
 ONLY SEAL (OPTIONAL)
 NUR DICHTUNG (OPTIONAL)
 cod. 0520013



PER BOCCOLE DI RIDUZIONE VEDI PAG. TBL150-1-00
 FOR REDUCING BUSHINGS SEE PAGE TBL150-1-00
 FÜR REDUZIERBUCHSE SIEHE SEITE TBL150-1-00

Cod. MT	N°Utensili N°Tools N°Werkzeuge	Reversibile lato mandrino/controlmandrino Reversible sub/main spindle side Umkehrbare Spindel-seite/ Gegenspindel-seite	Lubrificazione int. opzionale Coolant through optional Innenkühlung Optional	Lubrificazione est. Ext. coolant Aussenkühlung	Misure Dimensions Masse	D
0814000	1	X	X	X	mm	40
0813810	1	X	X	X	Inch	1 1/2"

SAMSUNG
 MOD: PL240 LM - PL250 VM - SL1500/2000 M/Y/SY

PORTAUTENSILE ASSIALE PER BARENO Ø40mm / Ø1 1/2" H=60mm
 Axial single boring bar holder Ø40mm / Ø1 1/2" H=60mm
 Axial Bohrhälter Ø40mm / Ø1 1/2" H=60mm

Subject to change without notice.

M.T. srl

Via Casino Albini 480
 Tel. 0541/956034-957884
 Fax 0541/956341
 47842 S. GIOVANNI IN M. (RN)
 e-mail: mtma@mtmarchetti.com
 http://www.mtmarchetti.com

PRODUZIONE MODULI ROTANTI



PAGINA SMG630-5-20

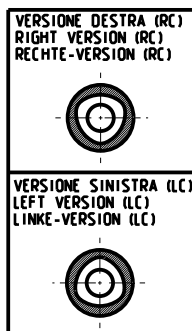
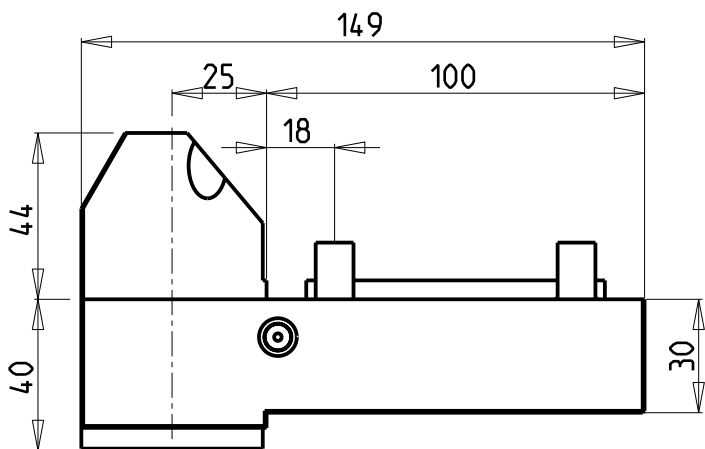
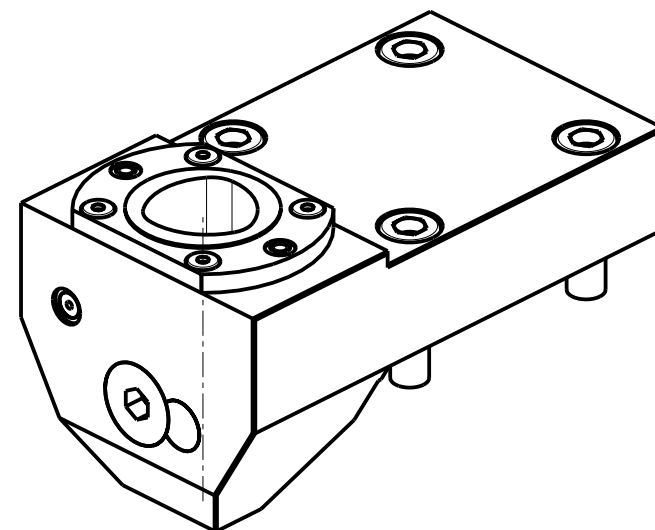
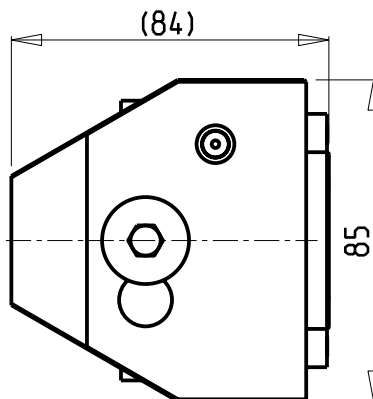
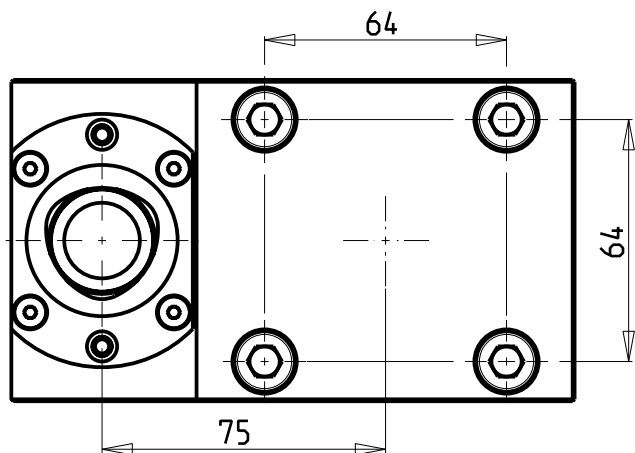

PER ORDINARE LA VERSIONE SX
AGGIUNGERE "LC" AL CODICE IN TABELLA.
ES: MNL0464010 DIVENTA MNL0464010LC

TO ORDER LEFT VERSION
ADD A "LC" IN THE CODE-CHARTS.
EXAMPLE: MNL0464010 BECOMES MNL0464010LC

UM DIE LINKE-VERSION ZU BESTELLEN, BEI DER
ARTIKELBEZEICHNUNG "LC" HINZUFUEGEN.
BEISPIEL: MNL0464010 WIRD DANN MNL0464010LC

Cod. MT	N°Utensili N°Tools N°Werkzeuge	Lubrificazione int. Coolant through Innenkuehlung	Reversibile lato mandrino/contromandrino Reversible sub/main spindle side Umkehrbare Spindelseite/ Gegenspindelseite	TAGLIA Size Masse
DW00444010	1	X	X	C4

SAMSUNG

MOD: PL240 LM - SL1500/2000 M/Y/SY

PORTAUTENSILE RADIALE SINGOLO ARRETRATO MT CAPTO

Single rear-set radial static tool MT CAPTO

Radial Single-Werkzeughalter zurueckversetzt MT CAPTO

Subject to change without notice.

M.T. srl

Via Casino Albini 480
Tel. 0541/956034-957884
Fax 0541/956341

47842 S. GIOVANNI IN M. (RN)
e-mail: mtma@mtmarchetti.com
http://www.mtmarchetti.com

PRODUZIONE MODULI ROTANTI



PAGINA SMG430-E-40

10/2018

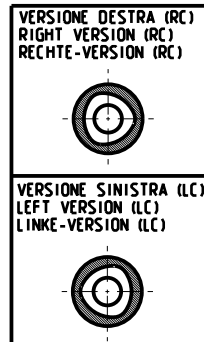
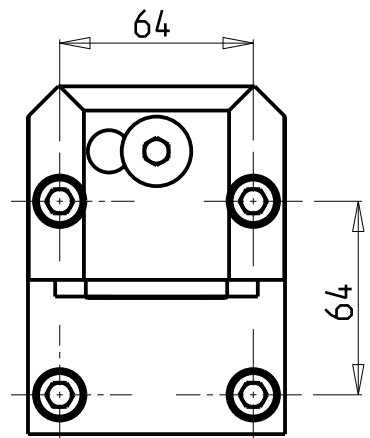
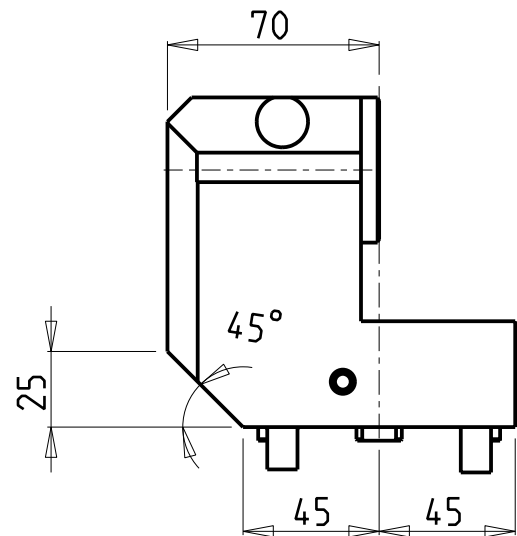
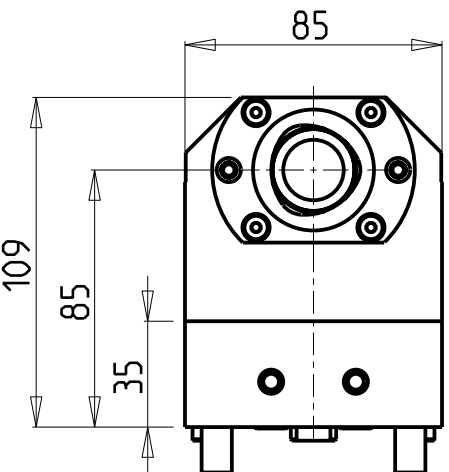

PER ORDINARE LA VERSIONE SX
AGGIUNGERE "LC" AL CODICE IN TABELLA.
ES: DW02434010 DIVENTA DW02434010LC

TO ORDER LEFT VERSION
ADD A "LC" IN THE CODE-CHARTS.
EXAMPLE: DW02434010 BECOMES DW02434010LC

UM DIE LINKE-VERSION ZU BESTELLEN, BEI DER
ARTIKELBEZEICHNUNG "LC" HINZUFUEGEN.
BEISPIEL: DW02434010 WIRD DANN DW02434010LC

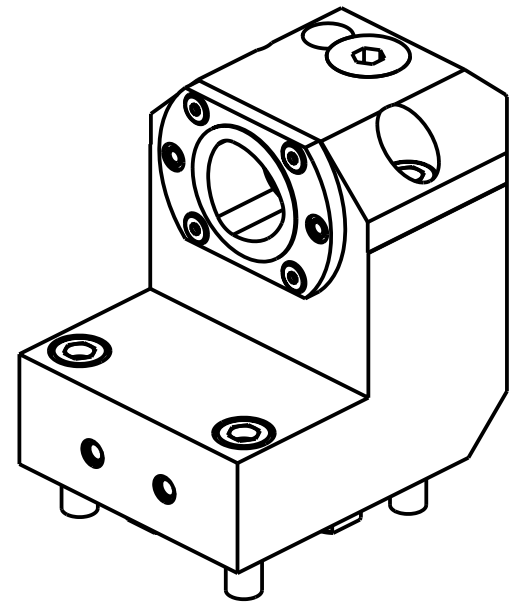

Cod. MT	Lubrificazione int. Coolant through Innenkuehlung	Reversibile lato mandrino/contromandrino Reversible sub/main spindle side Umkehrbare Spindelseite/ Gegenspindelseite	TAGLIA Size Masse
DW02434010	X	X	C4

SAMSUNG
 MOD: PL240 LM - SL1500/2000 M/Y/SY
 PORTAUTENSILE ASSIALE SINGOLO ARRETRATO MT CAPTO
 Axial rear-set boring single static tool MT CAPTO
 Axial Single-Werkzeughalter zurueckversetzt MT CAPTO

Subject to change without notice.

M.T. srl
 Via Casino Albini 480
 Tel. 0541/956034-957884
 Fax 0541/956341
 47842 S. GIOVANNI IN M. (RN)
 e-mail: mtma@mtmarchetti.com
 http://www.mtmarchetti.com

PRODUZIONE MODULI ROTANTI



PAGINA SMG555-E-40