

		PAGINA Page Seite
MODULO MOTORIZZATO ASSIALE H=55mm Axial driven tool H=55mm Axial angetriebenes Werkzeug H=55mm		HWC150.5.10

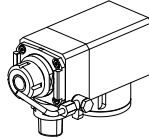
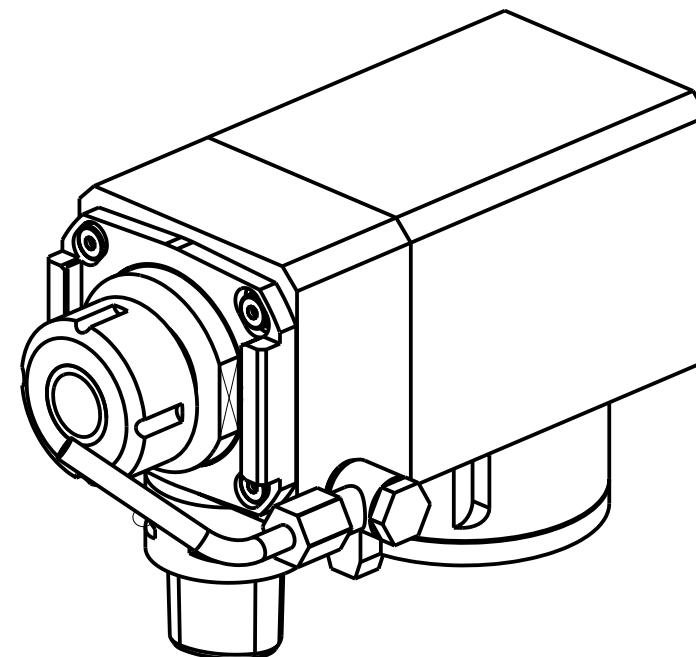
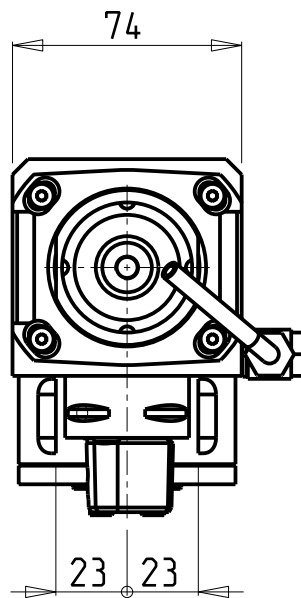
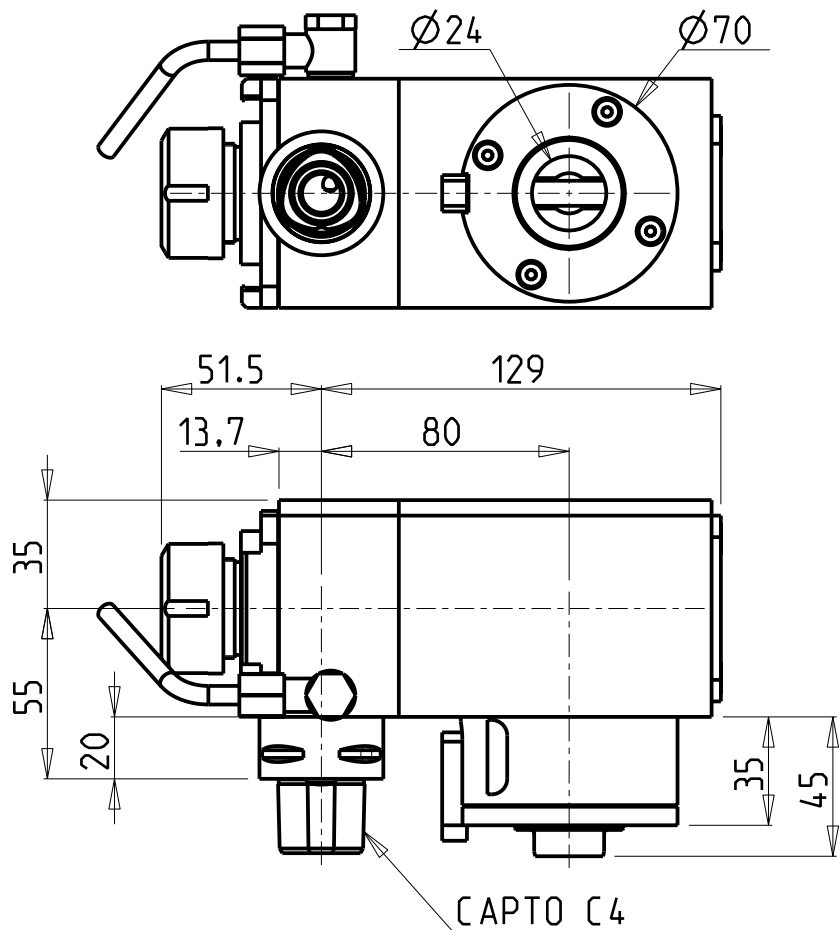

Cod. MT	Mandrino Spindle Spindel	I	RPM	Coppia Max Max Torque Max Drehmoment	Lubr. esterna Ext. coolant Aussenkuehlung	CHIAVI NON INCLUDE Keys not included Schluessel nicht einbegriffen	
SPC1911000	ER25	1:1	6000	50Nm	X	CHSTER25	MNZ0410005 *

- Chiave inclusa
- Key included
- Schluessel inbegriffen

HW ACHEON
C1 (Stazioni Capto C4 - Capto C4 Stations - Capto C4 Stationen)

MODULO MOTORIZZATO ASSIALE H=55mm
Axial driven tool H=55mm
Axial angetriebenes Werkzeug H=55mm

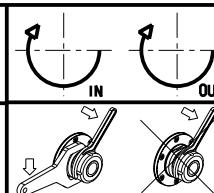

M.T. srl
 Via Casino Albini 480
 Tel. 0541/956034-957884
 Fax 0541/956341
 47842 S. GIOVANNI IN M. (RN)
 e-mail: mtma@mtmarchetti.com
 http://www.mtmarchetti.com

PRODUZIONE MODULI ROTANTI



PAGINA HWC150-5-10

Subject to change without notice.

10/2018

