

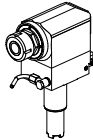

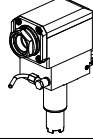
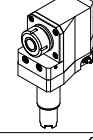

		PAGINA Page Seite
MODULO MOTORIZZATO RADIALE VD140 Radial driven tool VD140 Radial angetriebenes Werkzeug VD140		HAS013.3.20
MODULO MOTORIZZATO RADIALE MTSK VD140 Radial MTSK driven tool VD140 Radial MTSK angetriebenes Werkzeug VD140		HAS013.3.20.K
MODULO MOTORIZZATO RADIALE ARRETRATO VD140 Radial rear-set driven tool VD140 Radial angetriebenes Werkzeug zurueckversetzt VD140		HAS015.3.00
MODULO MOTORIZZATO ASSIALE VD140 Axial driven tool VD140 Axial angetriebenes Werkzeug VD140		HAS150.3.10
MODULO MOTORIZZATO ASSIALE MTSK VD140 Axial MTSK driven tool VD140 Axial MTSK angetriebenes Werkzeug VD140		HAS150.3.10.K
MODULO MOTORIZZATO ASSIALE DISASSATO 42mm VD140 Axial driven tool re-directed by 42mm VD140 Axial angetriebenes Werkzeug achsversetzt um 42mm VD140		HAS160.3.00
MODULO MOTORIZZ. ASSIALE MOLTIPLICATO I=1:2 DISASSATO 42mm VD140 Axial geared-up I=1:2 driven tool re-directed by 42mm VD140 Axial angetriebenes Werkzeug uebersetzt I=1:2 achsversetzt um 42mm VD140		HAS160.3.20
MODULO MOTORIZZ. ASSIALE MOLTIPLICATO I=1:3 DISASSATO 36mm VD140 Axial geared-up I=1:3 driven tool re-directed by 36mm VD140 Axial angetriebenes Werkzeug uebersetzt I=1:3 achsversetzt um 36mm VD140		HAS160.3.30
MODULO MOTORIZZATO RADIALE MOLTIPLICATO I=1:2 VD140 Radial geared-up I=1:2 driven tool VD140 Radial angetriebenes Werkzeug uebersetzt I=1:2 VD140		HAS203.3.10
MODULO MOTORIZZATO RADIALE MOLTIPLICATO I=1:3 VD140 Radial geared-up I=1:3 driven tool VD140 Radial angetriebenes Werkzeug uebersetzt I=1:3 VD140		HAS208.3.10
MODULO MOTORIZZATO RADIALE ARRETRATO MOLTIPLICATO I=1:3 VD140 Radial gear-up I=1:3 rear-set driven tool VD140 Radial angetriebenes Werkzeug uebersetzt I=1:3 zurueckversetzt VD140		HAS226.3.10
MODULO MOTORIZZATO ASSIALE BISPORGENTE DISASSATO 160mm VD140 Axial rear-set opposite face twin driven tool re-directed by 160mm VD140 Axial angetriebenes Werkzeug halb vospringend achsversetzt um 160mm VD140		HAS243.3.10

		PAGINA Page Seite
MODULO MOTORIZZATO RADIALE 2 USCITE IN Y VDI40 Radial single side twin head driven tool in Y VDI40 Radial angetriebenes Werkzeug 2 Ausgaenge in Y VDI40		HAS263.3.10
MODULO MOTORIZZATO ORIENTABILE ±90° VDI40 ±90° adjustable angle driven tool VDI40 Angetriebenes Werkzeug schwenkbar ±90° VDI40		HAS333.3.00
MODULO MOTORIZZATO ORIENTABILE ±90° CON NONIO DIGITALE VDI40 ±90° adjustable angle driven tool with digital display VDI40 Angetriebenes Werkzeug schwenkbar ±90° mit digital display VDI40		HAS333.3.01
MODULO MOTORIZZATO STOZZATORE CORSA 50mm VDI40 Slotting driven tool 50mm stroke VDI40 Keilnutenstossmaschine 50mm Hub VDI40		HAS360.3.30
MODULO MOTORIZZATO STOZZATORE CORSA 25mm VDI40 Slotting driven tool 25mm stroke VDI40 Keilnutenstossmaschine 25mm Hub VDI40		HAS360.3.31

ATTENZIONE - ATTENTION - ACHTUNG

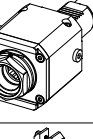
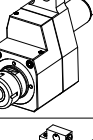
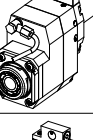
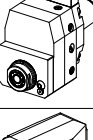
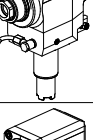
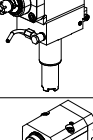
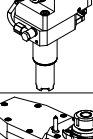
- Per lo smontaggio degli utensili utilizzare sempre la chiave di contrasto come indicato nel manuale d'uso.
- For disassembly of the tools use always the contrast key as mentioned in the user instructions.
- Fuer das Abmontieren der Werkzeuge immer den Gegenschlüssel benutzen wie in der Bedienungsanleitung erwaeht.

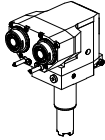
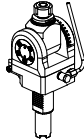
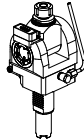
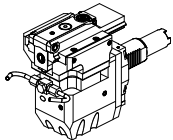
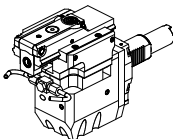
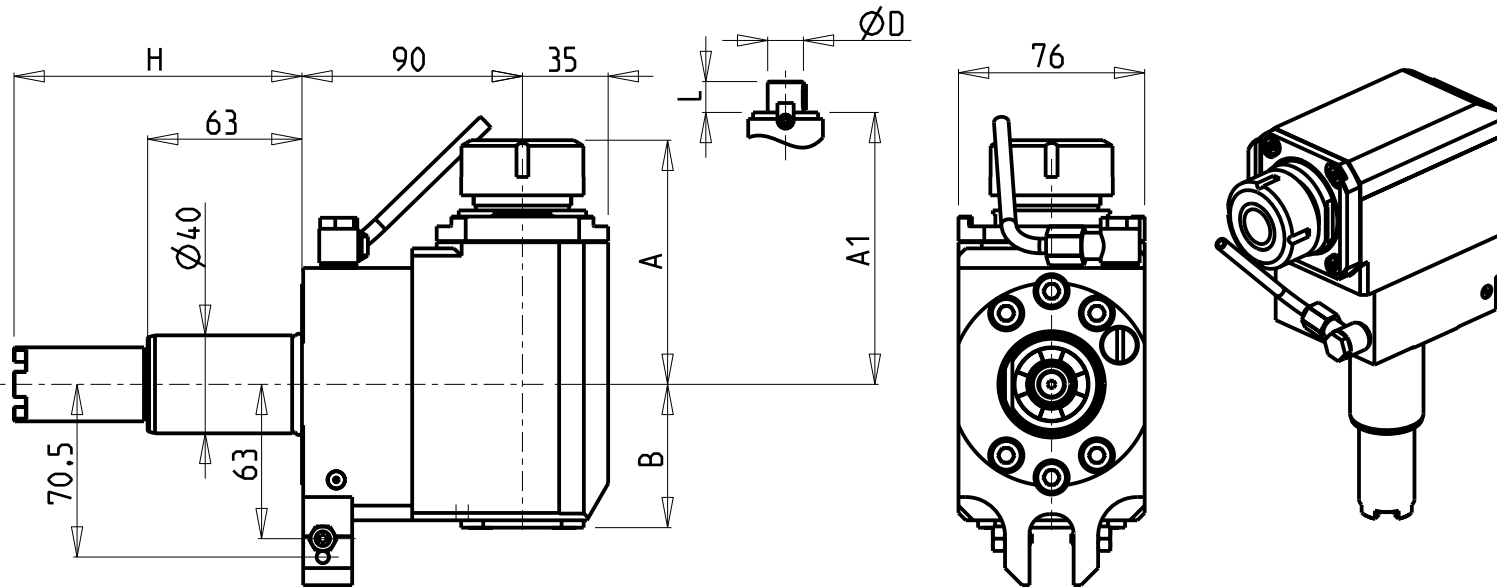

- Chiave inclusa
- Key included
- Schlüssel inbegriffen

Cod. MT	Mandrino Spindel Spindel	I	RPM	Coppia Max Max Torque Max Drehmoment	Lubrificazione int. Coolant through Innenkuhlung	Lubrificazione est. Ext. coolant Aussenkuhlung	A	A1	B	H	Tipo Torretta Turret type Revolver typ	CHIAVI NON INCLUSE Keys not included Schluessel nicht einbegriffen	
HAS0140132	ER32	1:1	6000	70Nm	-	X	99.7	-	58.5	117.55	VDI STANDARD / HYBRID TURRET	OKU0650004	CHSTER32
HAS0140232	ER32	1:1	6000	70Nm	P=70bar	X	99.7	-	69.5	117.55	VDI STANDARD / HYBRID TURRET	OKU0650004	CHSTER32
HAS0140140	ER40	1:1	6000	70Nm	-	X	103.7	-	58.5	117.55	VDI STANDARD / HYBRID TURRET	OKU0650004	CHSTER40
HAS0140240	ER40	1:1	6000	70Nm	P=70bar	X	103.7	-	69.5	117.55	VDI STANDARD / HYBRID TURRET	OKU0650004	CHSTER40
HAS0142219	Ø22x19	1:1	6000	70Nm	-	X	-	78.5	58.5	117.55	VDI STANDARD / HYBRID TURRET	CHUB41	CH_VTCROCE_M10
HAS0142721	Ø27x21	1:1	6000	70Nm	-	X	-	78.5	58.5	117.55	VDI STANDARD / HYBRID TURRET	CHUB41	CH_VTCROCE_M12

HAAS
 MOD: ST10/15/20/25/30/35 - DS30 - TL15/25

MODULO MOTORIZZATO RADIALE VDI40
 Radial driven tool VDI40
 Radial angetriebenes Werkzeug VDI40

Subject to change without notice.

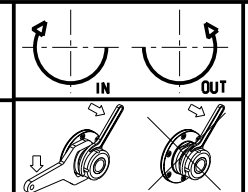

M.T. srl
 Via Casino Albini 480
 Tel. 0541/956034-957884
 Fax 0541/956341
 47842 S. GIOVANNI IN M. (RN)
 e-mail: mtma@mtmarchetti.com
 http://www.mtmarchetti.com

PRODUZIONE MODULI ROTANTI

 PAGINA HAS013-3-20

ATTENZIONE - ATTENTION - ACHTUNG

- Per lo smontaggio degli utensili utilizzare sempre la chiave di contrasto come indicato nel manuale d'uso.
- For disassembly of the tools use always the contrast key as mentioned in the user instructions.
- Fuer das Abmontieren der Werkzeuge immer den Gegenschlüssel benutzen wie in der Bedienungsanleitung erwäehnt.

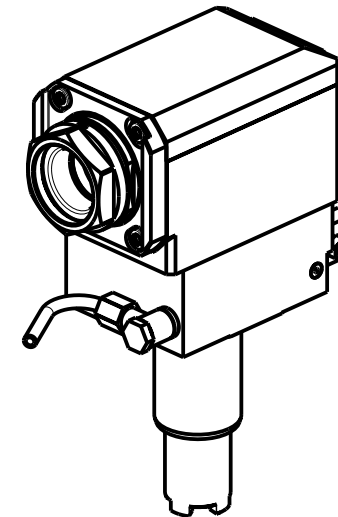
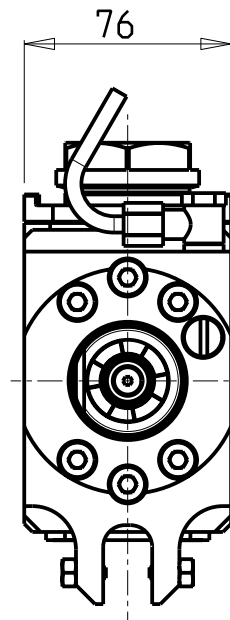
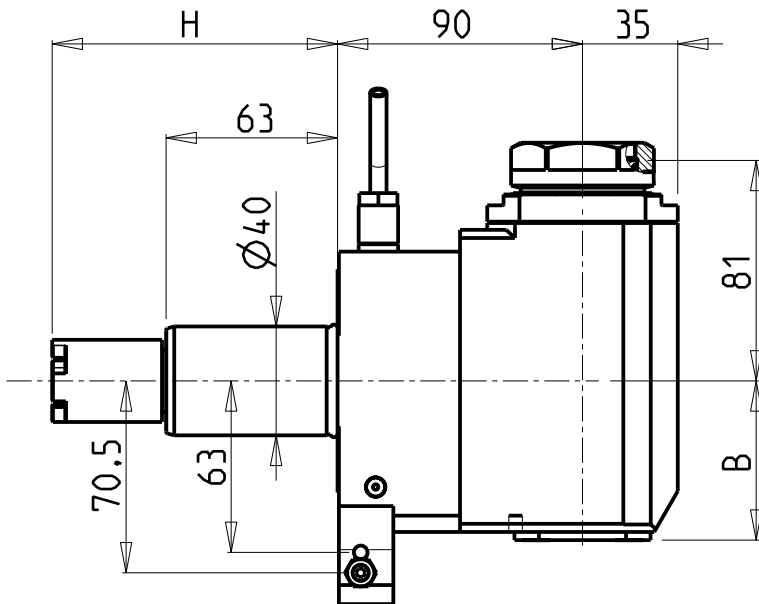

- Chiave inclusa
- Key included
- Schlüssel inbegriffen

PER PORTAUTENSILI MODULARI MTSK-40 VEDI PAG. TBL300-1-40
 FOR MTSK-40 QUIK CHANGE TOOLHOLDERS CLAMPINGS SEE PAGE TBL300-1-40
 FUER MTSK-40 MODULARE WERKZEUGAUFNAHMEN SIEHE SEITE TBL300-1-40

Cod. MT	Mandrino Spindle Spindel	I	RPM	Coppia Max Max Torque Max Drehmoment	Lubrificazione int. Coolant through Innenkuehlung	Lubrificazione est. Ext. coolant Aussenkuehlung	B	H	Tipo Torretta Turret type Revolver typ	CHIAVI NON INCLUSE Keys not included Schlüssel nicht einbegriffen	
HAS0280140	MTSK-40	1:1	6000	70Nm	-	X	58.5	117.55	VDI STANDARD / HYBRID TURRET	CHUB46	OKU0650004 ▪
HAS0280240	MTSK-40	1:1	6000	70Nm	P=70bar	X	69.5	117.55	VDI STANDARD / HYBRID TURRET	CHUB46	OKU0650004 ▪

HAAS
 MOD: ST10/15/20/25/30/35 - DS30 - TL15/25

MODULO MOTORIZZATO RADIALE MTSK VD140
 Radial MTSK driven tool VD140
 Radial MTSK angetriebenes Werkzeug VD140

Subject to change without notice.

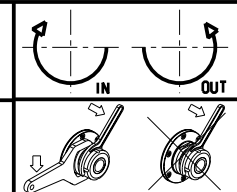

M.T. srl
 Via Casino Albini 480
 Tel. 0541/956034-957884
 Fax 0541/956341
 47842 S. GIOVANNI IN M. (RN)
 e-mail: mtma@mtmarchetti.com
 http://www.mtmarchetti.com

PRODUZIONE MODULI ROTANTI



PAGINA HAS013-3-20-K

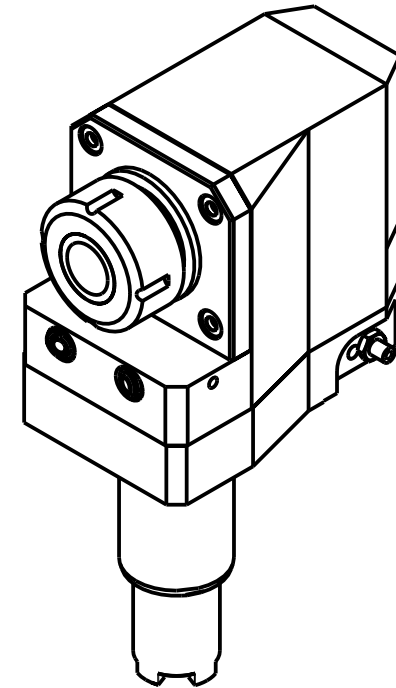
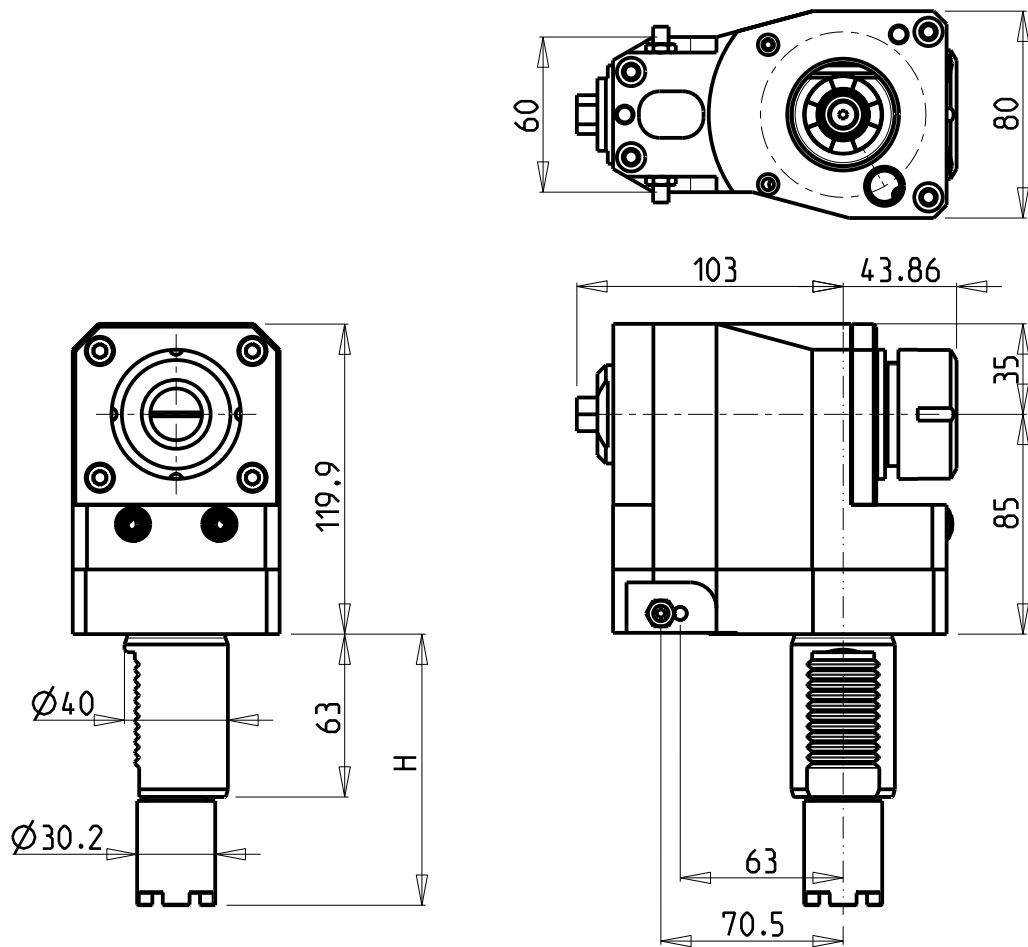

Cod. MT	Mandrino Spindle Spindel	I	RPM	Coppia Max Max Torque Max Drehmoment	Lubrificazione est. Ext. coolant Aussenkuehlung	H	Tipo Torretta Turret Type Revolver Typ	CHIAVI NON INCLUSE Keys not included Schlüssel nicht einbegriffen	
HAS0040232	ER32	1:1	6000	70Nm	X	117.55	VDI STANDARD / HYBRID TURRET	CHUB13	CHSTER32

HAAS
MOD: ST10/15/20/25/30/35 - DS30 - TL15/25

MODULO MOTORIZZATO RADIALE ARRETRATO VDI40
Radial rear-set driven tool VDI40
Radial angetriebenes Werkzeug zurueckversetzt VDI40

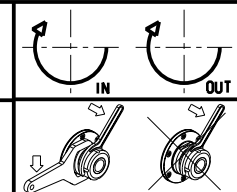

M.T. srl
Via Casino Albini 480
Tel. 0541/956034-957884
Fax 0541/956341
47842 S. GIOVANNI IN M. (RN)
e-mail: mtma@mtmarchetti.com
http://www.mtmarchetti.com

PRODUZIONE MODULI ROTANTI

PAGINA HAS015-3-00

Subject to change without notice.

10/2018

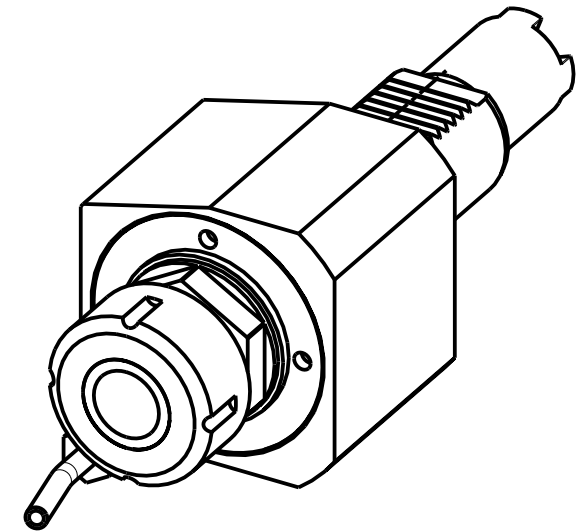
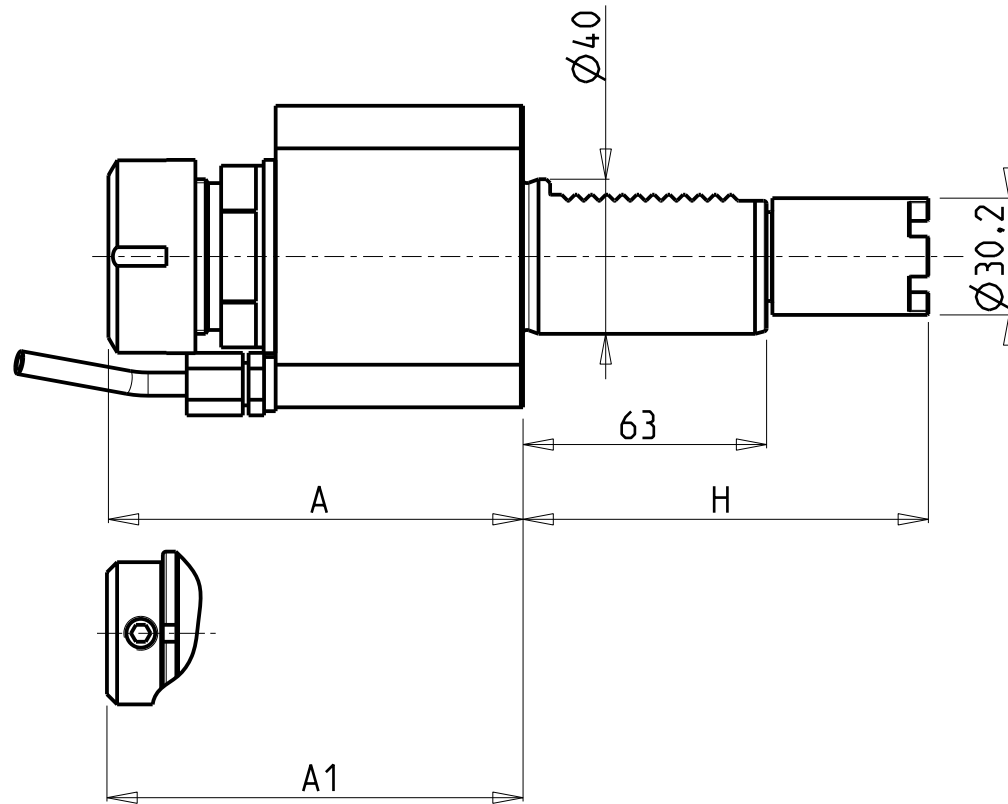
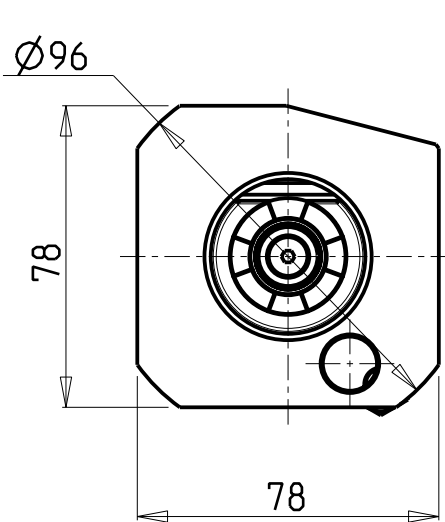

- Chiave inclusa
- Key included
- Schlüssel einbegriffen

Cod. MT	Mandrino Spindle Spindel	I	RPM	Coppia Max Max Torque Max Drehmoment	Lubrificazione est. Ext. coolant Aussenkuhlung	Lubrificazione int. Coolant through Innenkuehlung	A	A1	H	Tipo Torretta Turret Type Revolver Typ	CHIAVI NON INCLUSE Keys not included Schlüssel nicht einbegriffen		
											CHUB41	CHSTER32	
HAS0020232	ER32	1:1	6000	70Nm	X	-	107.26	-	117.55	VDI STANDARD / HYBRID TURRET	CHUB41	CHSTER32	
HAS0020132	ER32	1:1	6000	70Nm	X	P=30bar	110.46	-	117.55	VDI STANDARD / HYBRID TURRET	CHUB41	CHSTER32	
HAS0020325	ERA25	1:1	6000	70Nm	X	-	74	-	117.55	VDI STANDARD / HYBRID TURRET	CHUB42	CHTAER25ZC	CHUB27
HAS0020525	WELDON25	1:1	6000	70Nm	X	-	-	97.1	117.55	VDI STANDARD / HYBRID TURRET	-	-	

HAAS
MOD: ST10/15/20/25/30/35 - DS30 - TL15/25

MODULO MOTORIZZATO ASSIALE VDI40
Axial driven tool VDI40
Axial angetriebenes Werkzeug VDI40

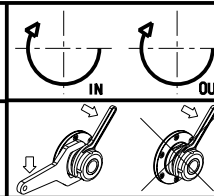

M.T. srl
Via Casino Albini 480
Tel. 0541/956034-957884
Fax 0541/956341
47842 S. GIOVANNI IN M. (RN)
e-mail: mtma@mtmarchetti.com
http://www.mtmarchetti.com

PRODUZIONE MODULI ROTANTI



PAGINA HAS150-3-10

Subject to change without notice.

10/2018

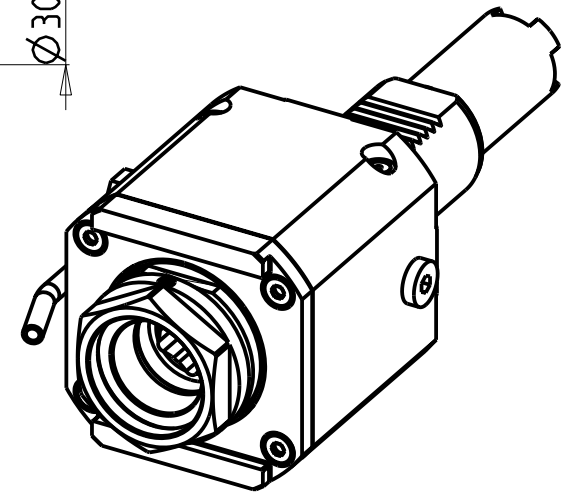
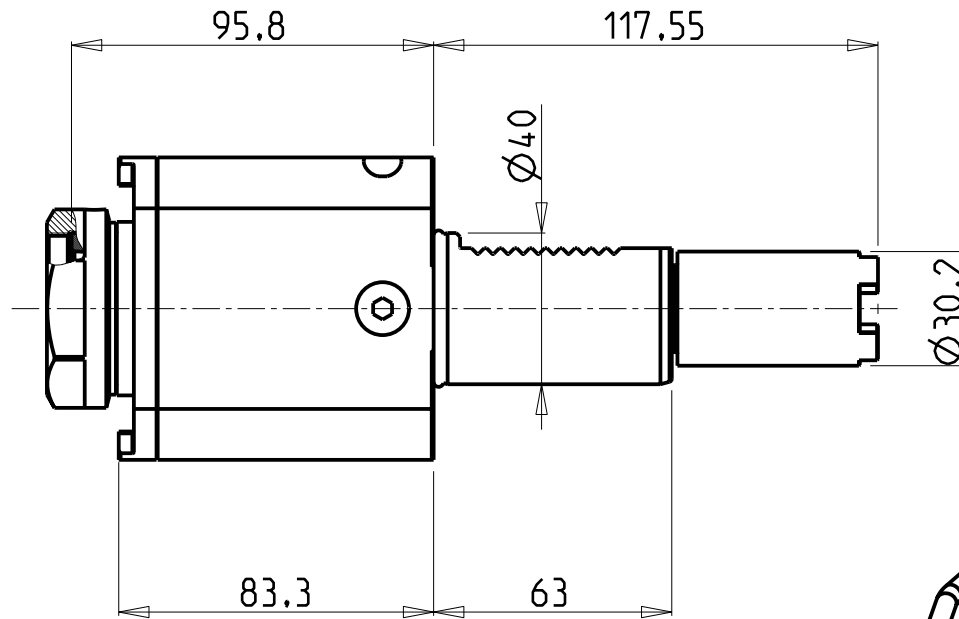
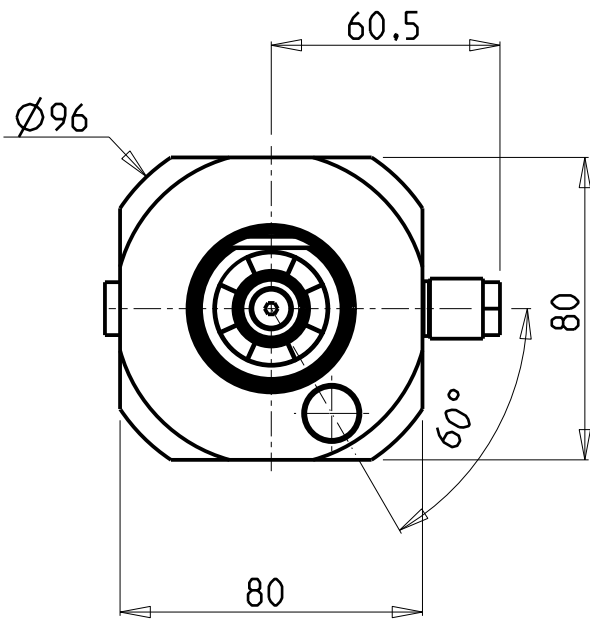

PER PORTAUTENSILI MODULARI MTSK-40 VEDI PAG. TBL300-1-40
 FOR MTSK-40 QUICK CHANGE TOOLHOLDERS CLAMPINGS SEE PAGE TBL300-1-40
 FUER MTSK-40 MODULARE WERKZEUGAUFNAHMEN SIEHE SEITE TBL300-1-40

Cod. MT	Mandrino Spindle Spindel	I	RPM	Coppia Max Max Torque Max Drehmoment	Lubrificazione est. Ext. coolant Aussenkühlung	Tipo Torretta Turret Type Revolver Typ	CHIAVI NON INCLUSE Keys not included Schlüssel nicht einbegriffen	
HAS0500140	MTSK-40	1:1	6000	70Nm	X	VDI STANDARD / HYBRID TURRET	CHUB46	OKU0650004 *

- Chiave inclusa
- Key included
- Schlüssel einbegriffen

HAAS

MOD: ST10/15/20/25/30/35 - DS30 - TL15/25

MODULO MOTORIZZATO ASSIALE MTSK VDI40

Axial MTSK driven tool VDI40

Axial MTSK angetriebenes Werkzeug VDI40

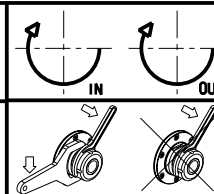

M.T. srl
 Via Casino Albini 480
 Tel. 0541/956034-957884
 Fax 0541/956341
 47842 S. GIOVANNI IN M. (RN)
 e-mail: mtma@mtmarchetti.com
 http://www.mtmarchetti.com

PRODUZIONE MODULI ROTANTI



PAGINA HAS150-3-10-K

Subject to change without notice.

10/2018

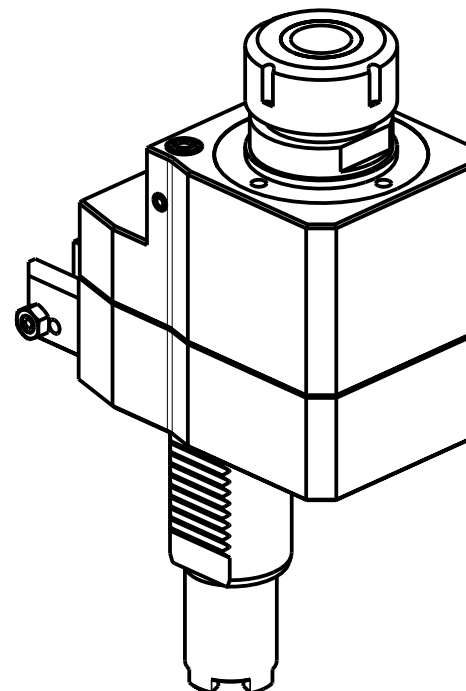
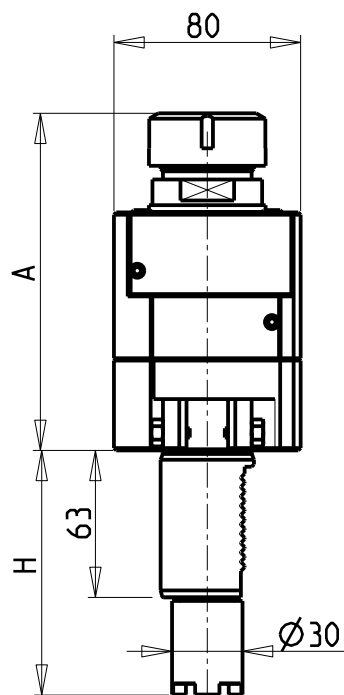
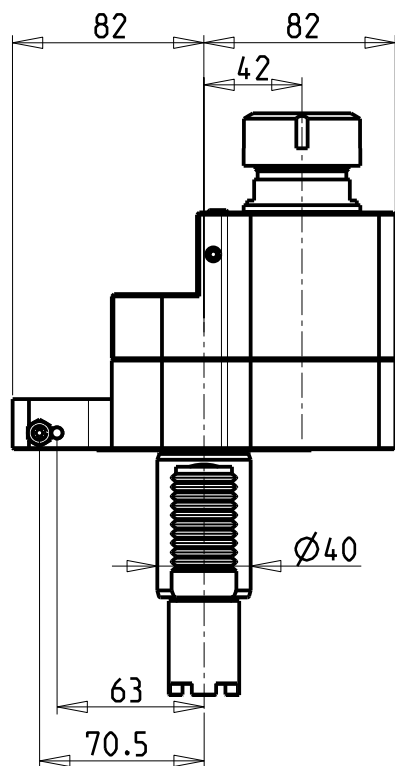

Cod. MT	Mandrino Spindle Spindel	I	RPM	Coppia Max Max Torque Max Drehmoment	Lubrificazione int. Coolant through Innenkühlung	Lubrificazione est. Ext. coolant Aussenkühlung	A	H	Tipo Torretta Turret Type Revolver Typ	CHIAVI NON INCLUSE Keys not included Schlüssel nicht einbegriffen	
HAS0080032	ER32	1:1	6000	70Nm		X	144.66	117.55	VDI STANDARD / HYBRID TURRET	CHUB41	CHSTER32
HAS0081132	ER32	1:1	6000	70Nm	P=30bar		164.96	117.55	VDI STANDARD / HYBRID TURRET	CHUB38	CHSTER32
HAS0082132	ER32	2:1	3000	100Nm		X	144.66	117.55	VDI STANDARD / HYBRID TURRET	CHUB41	CHSTER32
HAS0084232	ER32	2:1	3000	100Nm	P=30bar		164.96	117.55	VDI STANDARD / HYBRID TURRET	CHUB38	CHSTER32

HAAS

MOD: ST10/15/20/25/30/35 - DS30 - TL15/25

MODULO MOTORIZZATO ASSIALE DISASSATO 42mm VDI40

Axial driven tool re-directed by 42mm VDI40

Axial angetriebenes Werkzeug achsversetzt um 42mm VDI40

Subject to change without notice.

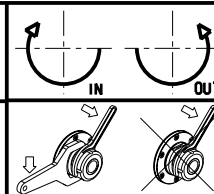

M.T. srl

Via Casino Albini 480
Tel. 0541/956034-957884
Fax 0541/956341

47842 S. GIOVANNI IN M. (RN)
e-mail: mtma@mtmarchetti.com
http://www.mtmarchetti.com

PRODUZIONE MODULI ROTANTI



PAGINA HAS160-3-00

10/2018

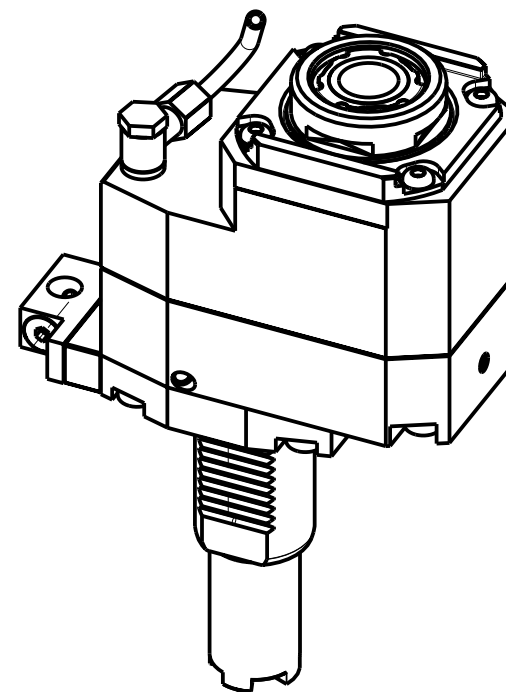
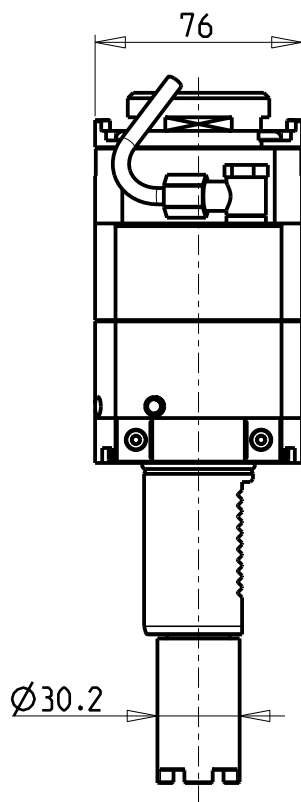
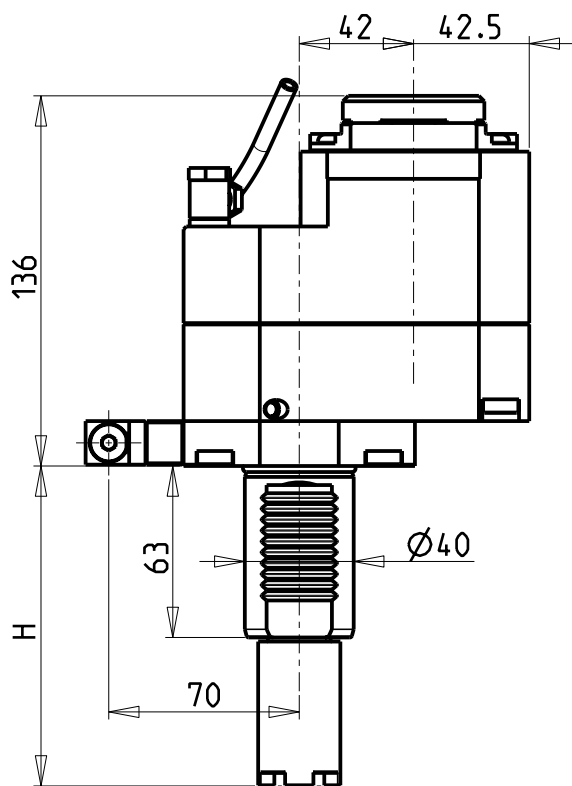

- Chiave inclusa
- Key included
- Schlüssel inbegriffen

Cod. MT	Mandrino Spindle Spindel	I	RPM	Coppia Max Max Torque Max Drehmoment	Lubrificazione int. Coolant through Innenkühlung	Lubrificazione est. Ext. coolant Aussenkühlung	H	Tipo Torretta Turret Type Revolver Typ	CHIAVI NON INCLUSE Keys not included Schlüssel nicht einbegriffen		
HAS0317132	ERA32	1:2	12000	45Nm	-	X	117.55	VDI STANDARD / HYBRID TURRET	CHUB30	CHTAER32ZC	OKU0650004
HAS0317232	ERA32	1:2	12000	45Nm	P=70bar	X	117.55	VDI STANDARD / HYBRID TURRET	CHUB30	CHTAER32ZC	OKU0650004

HAAS
 MOD: ST10/15/20/25/30/35 - DS30 - TL15/25
 MODULO MOTORIZZATO ASSIALE MOLTIPLICATO I=1:2 DISASSATO 42mm VDI40
 Axial geared-up I=1:2 driven tool re-directed by 42mm VDI40
 Axial angetriebenes Werkzeug uebersetzt I=1:2 achsversetzt um 42mm VDI40

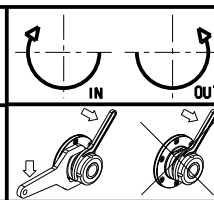

M.T. srl
 Via Casino Albini 480
 Tel. 0541/956034-957884
 Fax 0541/956341
 47842 S. GIOVANNI IN M. (RN)
 e-mail: mtma@mtmarchetti.com
 http://www.mtmarchetti.com

PRODUZIONE MODULI ROTANTI

 PAGINA HAS160-3-20

Subject to change without notice.

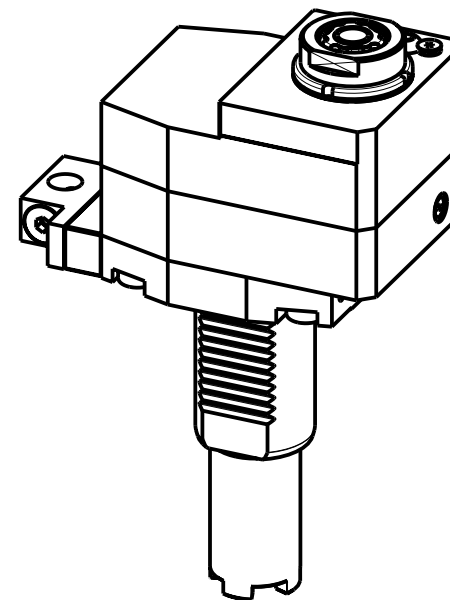
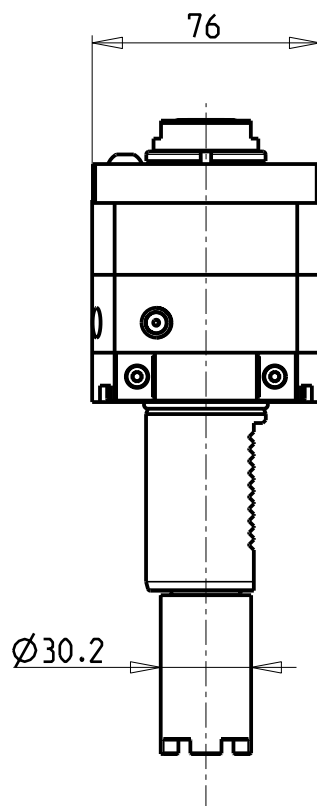
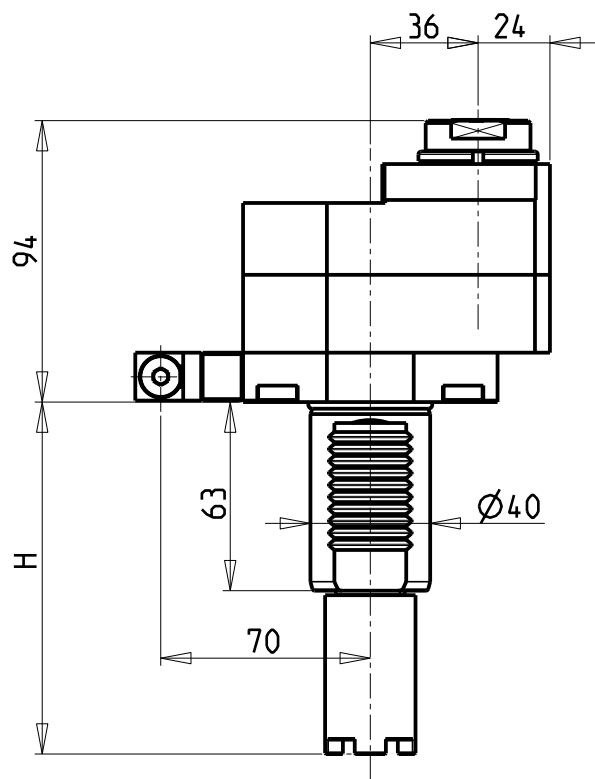
10/2018



- Chiave inclusa
- Key included
- Schluessel inbegriffen

Cod. MT	Mandrino Spindle Spindel	I	RPM	Coppia Max Max Torque Max Drehmoment	Lubrificazione int. Coolant through Innenkühlung	Lubrificazione est. Ext. coolant Aussenkühlung	H	Tipo Torretta Turret Type Revolver Typ	CHIAVI NON INCLUSE Keys not included Schluessel nicht einbegriffen		
HAS0380116	ERA16	1:3	18000	10Nm	-	X	117.55	VDI STANDARD / HYBRID TURRET	CHUB30	CHUB19_SP3	CHTAER16ZC
HAS0380216	ERA16	1:3	18000	10Nm	P=70bar	X	117.55	VDI STANDARD / HYBRID TURRET	CHUB30	CHUB19_SP3	CHTAER16ZC

HAAS

MOD: ST10/15/20/25/30/35 - DS30 - TL15/25

MODULO MOTORIZZATO ASSIALE MOLTIPLICATO I=1:3 DISASSATO 36mm VDI40

Axial geared-up I=1:3 driven tool re-directed by 36mm VDI40

Axial angetriebenes Werkzeug uebersetzt I=1:3 achsversetzt um 36mm VDI40

Subject to change without notice.

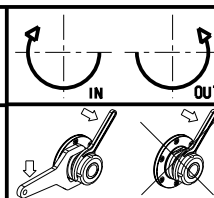

M.T. srl

Via Casino Albini 480
Tel. 0541/956034-957884
Fax 0541/956341

47842 S. GIOVANNI IN M. (RN)
e-mail: mtma@mtmarchetti.com
http://www.mtmarchetti.com

PRODUZIONE MODULI ROTANTI



PAGINA HAS160-3-30

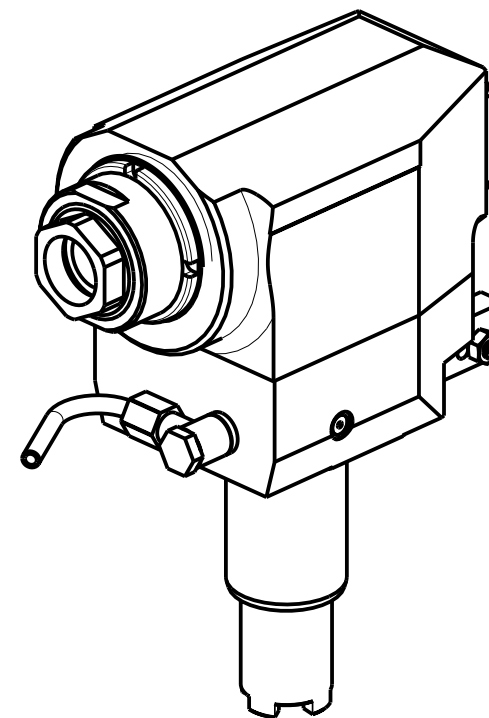
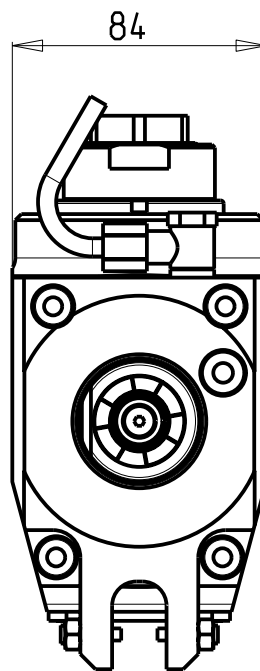
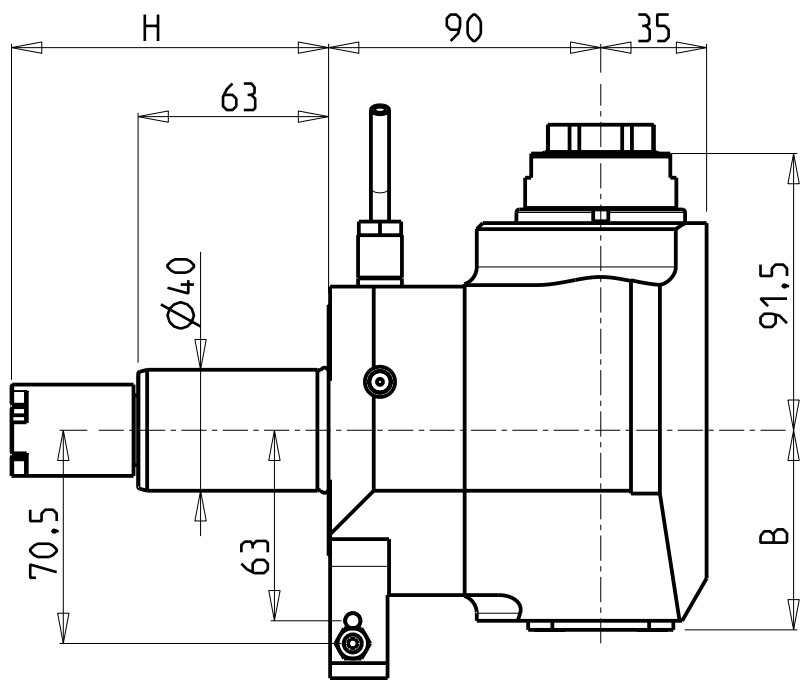

Cod. MT	Mandrino Spindle Spindel	I	RPM	Coppia Max Max Torque Max Drehmoment	Lubrificazione int. Coolant through Innenkühlung	Lubrificazione est. Ext. coolant Aussenkühlung	B	H	Tipo Torretta Turret type Revolver typ	CHIAVI NON INCLUSE Keys not included Schluessel nicht einbegriffen	
HAS0160132	ERA32	1:2	12000	30Nm		X	66	117.55	VDI STANDARD / HYBRID TURRET	CHUB46	CHUB32
HAS0160232	ERA32	1:2	12000	30Nm	P=70bar	X	76	117.55	VDI STANDARD / HYBRID TURRET	CHUB46	CHUB32

HAAS

MOD: ST10/15/20/25/30/35 - DS30 - TL15/25

MODULO MOTORIZZATO RADIALE MOLTIPLICATO I=1:2 VDI40

Radial geared-up I=1:2 driven tool VDI40

Radial angetriebenes Werkzeug uebersetzt I=1:2 VDI40

Subject to change without notice.

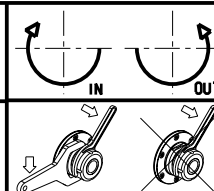

M.T. srl

Via Casino Albini 480
Tel. 0541/956034-957884
Fax 0541/956341

47842 S. GIOVANNI IN M. (RN)
e-mail: mtma@mtmarchetti.com
http://www.mtmarchetti.com

PRODUZIONE MODULI ROTANTI



PAGINA HAS203-3-10

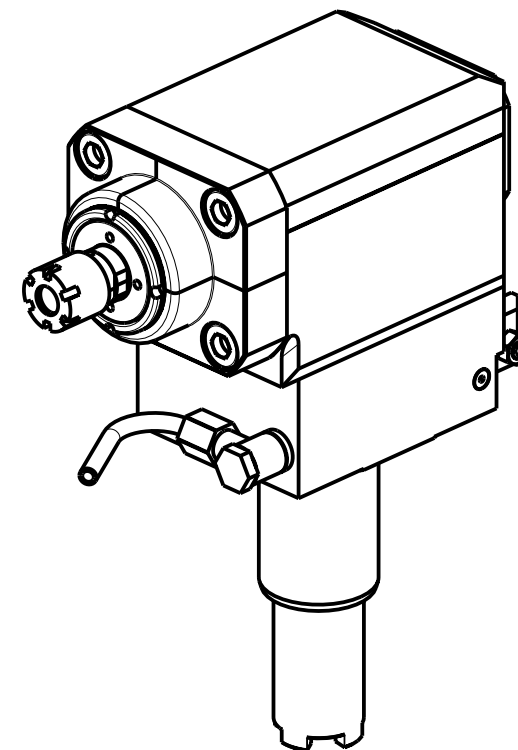
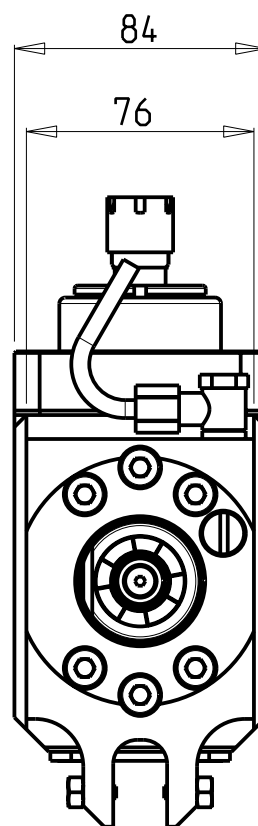
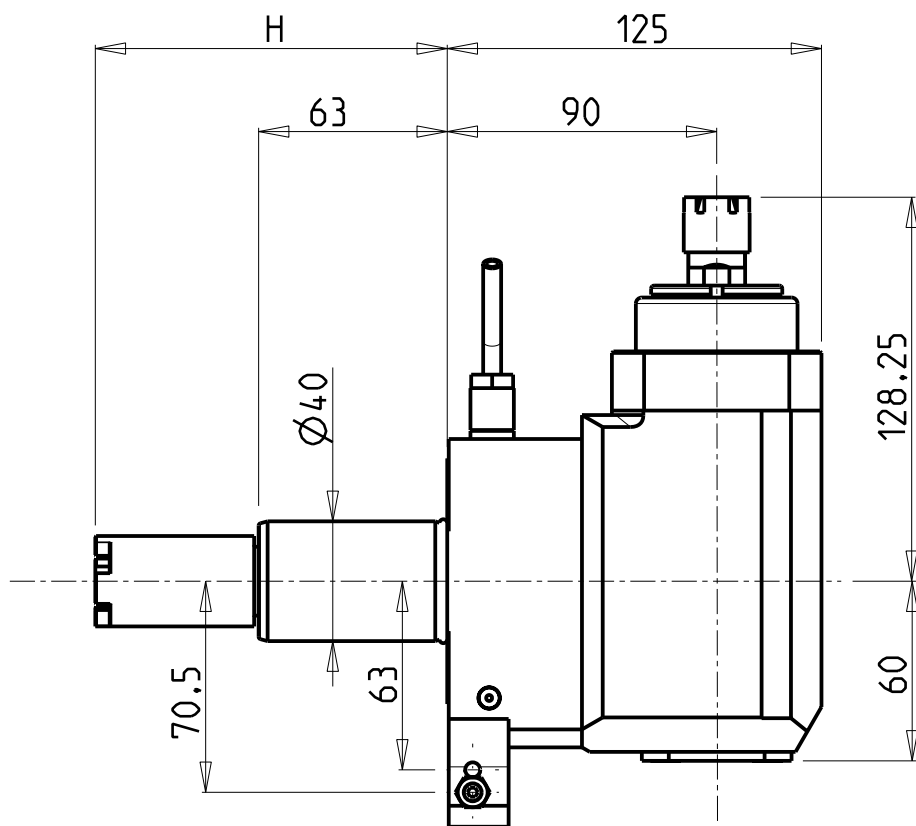

Cod. MT	Mandrino Spindle Spindel	I	RPM	Coppia Max Max Torque Max Drehmoment	Lubrificazione est. Ext. coolant Aussekkühlung	H	Tipo Torretta Turret type Revolver typ	CHIAVI INCLUSE Keys included Schluessel einbegriffen	
HAS0340016	ER16	1:3	18000	10Nm	X	117.55	VDI STANDARD / HYBRID TURRET	CHUB17	CHMNER16

HAAS
 MOD: ST10/15/20/25/30/35 - DS30 - TL15/25

MODULO MOTORIZZATO RADIALE MOLTIPLICATO I=1:3 VDI40
 Radial geared-up I=1:3 driven tool VDI40
 Radial angetriebenes Werkzeug uebersetzt I=1:3 VDI40

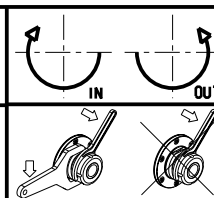

M.T. srl
 Via Casino Albini 480
 Tel. 0541/956034-957884
 Fax 0541/956341
 47842 S. GIOVANNI IN M. (RN)
 e-mail: mtma@mtmarchetti.com
 http://www.mtmarchetti.com

PRODUZIONE MODULI ROTANTI



PAGINA HAS208-3-10

Subject to change without notice.

10/2018

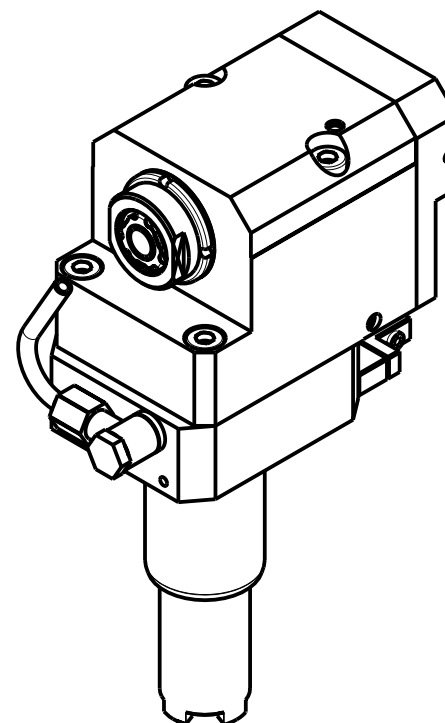
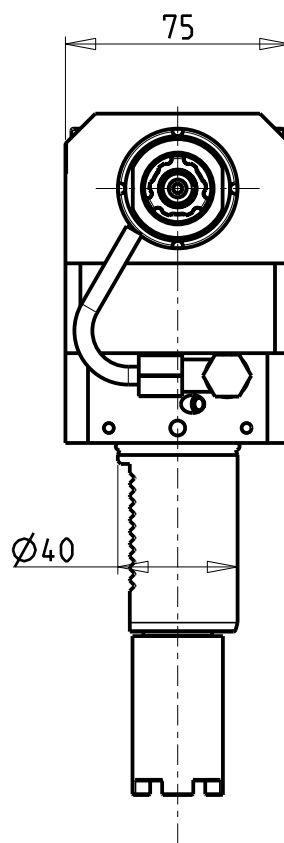
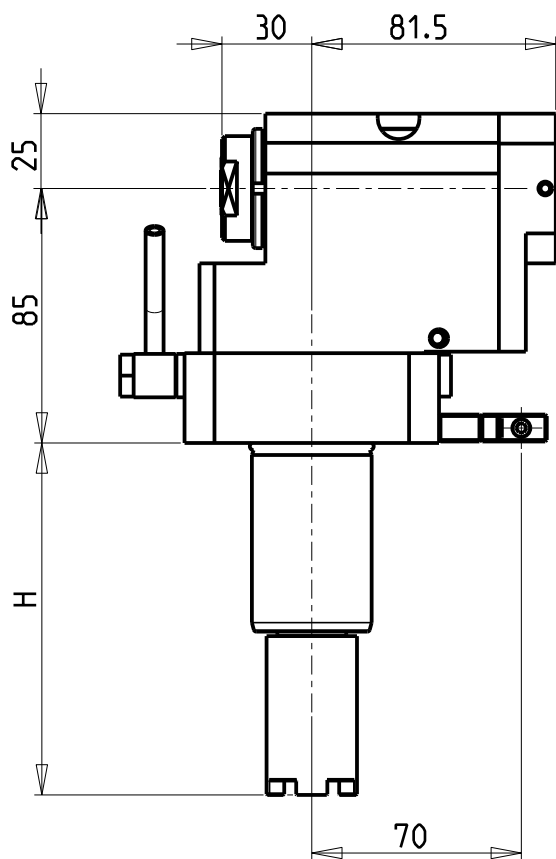

- Chiave inclusa
- Key included
- Schluessel inbegriffen

Cod. MT	Mandrino Spindle Spindel	I	RPM	Coppia Max Max Torque Max Drehmoment	Lubrificazione int. Coolant through Innenkühlung	Lubrificazione est. Ext. coolant Aussenkühlung	H	Tipo Torretta Turret Type Revolver Typ	CHIAVI NON INCLUSE Keys not included Schluessel nicht einbegriffen		
HAS0410116	ERA16	1:3	18000	10Nm	-	X	117,55	VDI STANDARD / HYBRID TURRET	CHUB30	CHUB19_SP3	CHTAER16ZC
HAS0410216	ERA16	1:3	18000	10Nm	P=70bar	X	117,55	VDI STANDARD / HYBRID TURRET	CHUB30	CHUB19_SP3	CHTAER16ZC

HAAS
 MOD: ST10/15/20/25/30/35 - DS30 - TL15/25
 MODULO MOTORIZZATO RADIALE ARRETRATO MOLTIPLICATO I=1:3 VDI40
 Radial gear-driven rear-set driven tool VDI40
 Radial angetriebenes Werkzeug uebersetzt I=1:3 zurueckversetzt VDI40

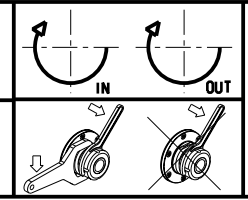

M.T. srl
 Via Casino Albini 480
 Tel. 0541/956034-957884
 Fax 0541/956341
 47842 S. GIOVANNI IN M. (RN)
 e-mail: mtma@mtmarchetti.com
 http://www.mtmarchetti.com

PRODUZIONE MODULI ROTANTI

PAGINA HAS226-3-10

Subject to change without notice.

ATTENZIONE - ATTENTION - ACHTUNG

- VERIFICARE LE MISURE DI INGOMBRO PER POSSIBILE INTERFERENZA SU ALCUNI MODELLI DI MACCHINE
- Please check the overall sizes for possible interferences on some machine models
- Bitte überprüfen sie das ausmass um mögliche interferenzen auf einigen maschinen modellen zu vermeiden

ATTENZIONE - ATTENTION - ACHTUNG

- Per lo smontaggio degli utensili utilizzare sempre la chiave di contrasto come indicato nel manuale d'uso.
- For disassembly of the tools use always the contrast key as mentioned in the user instructions.
- Fuer das Abmontieren der Werkzeuge immer den Gegenschlüssel benutzen wie in der Bedienungsanleitung erwäehnt.

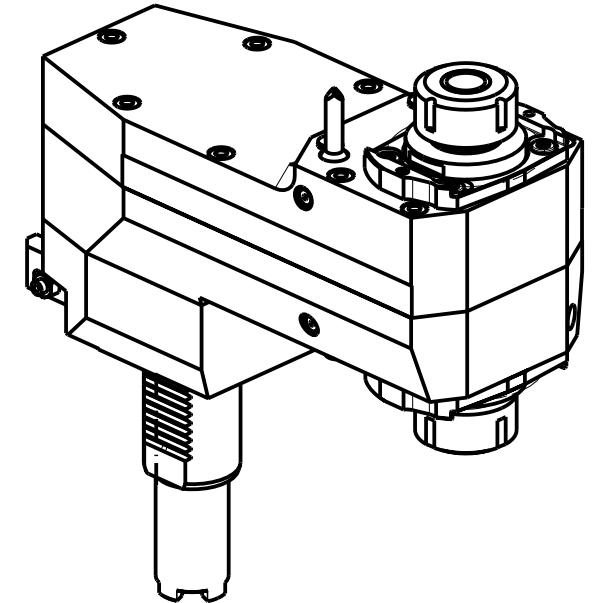
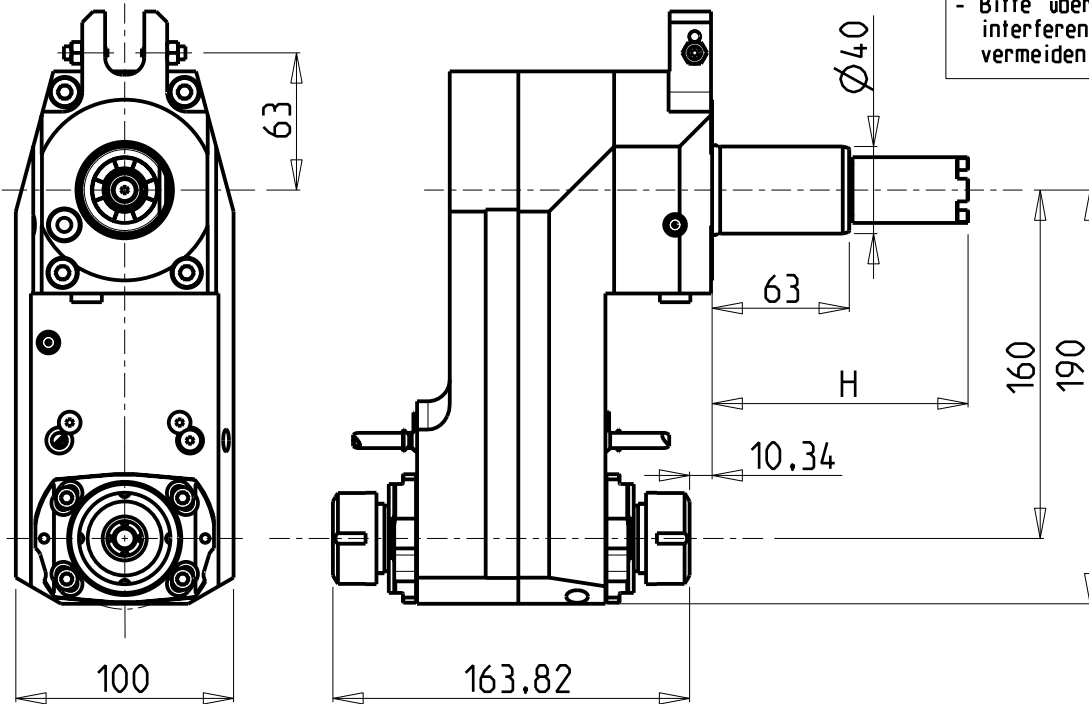

Cod. MT	Mandrino Spindle Spindel	I	RPM	Coppia Max Max Torque Max Drehmoment	Lubrificazione est. Ext. coolant Aussenkuehlung	H	Tipo Torretta Turret type Revolver typ	CHIAVI NON INCLUSE Keys not included Schlüssel nicht einbegriffen	
HAS0230225	ER25+ER25	1:1	6000	70Nm	X	117.55	VDI STANDARD / HYBRID TURRET	OKU0650004	CHSTER25

- Chiave inclusa
- Key included
- Schlüssel inbegriffen

HAAS
 MOD: DS30 - TL15/25
 MODULO MOTORIZZATO ASSIALE BISPORGENTE DISASSATO 160mm VDI40
 Axial rear-set opposite face twin driven tool re-directed by 160mm VDI40
 Axial angetriebenes Werkzeug halb vospriengend achsversetzt um 160mm VDI40



M.T. srl
 Via Casino Albini 480
 Tel. 0541/956034-957884
 Fax 0541/956341
 47842 S. GIOVANNI IN M. (RN)
 e-mail: mtma@mtmarchetti.com
 http://www.mtmarchetti.com

PRODUZIONE MODULI ROTANTI



PAGINA HAS243-3-10

Subject to change without notice.

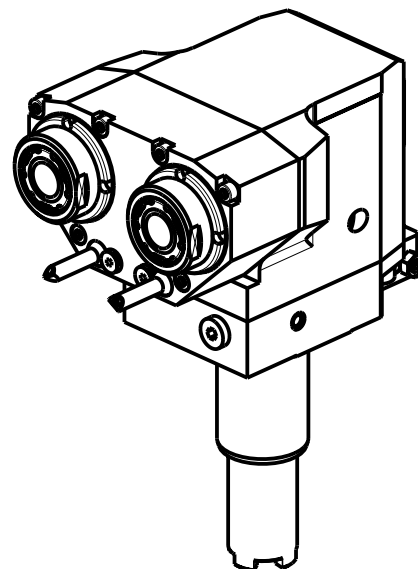
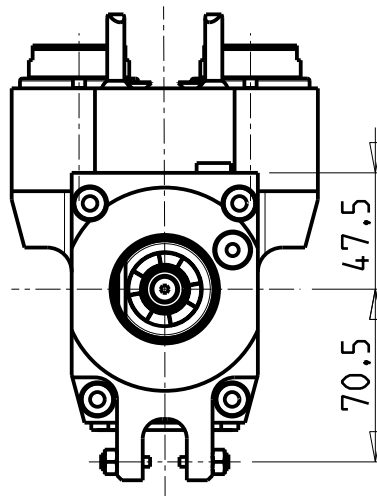
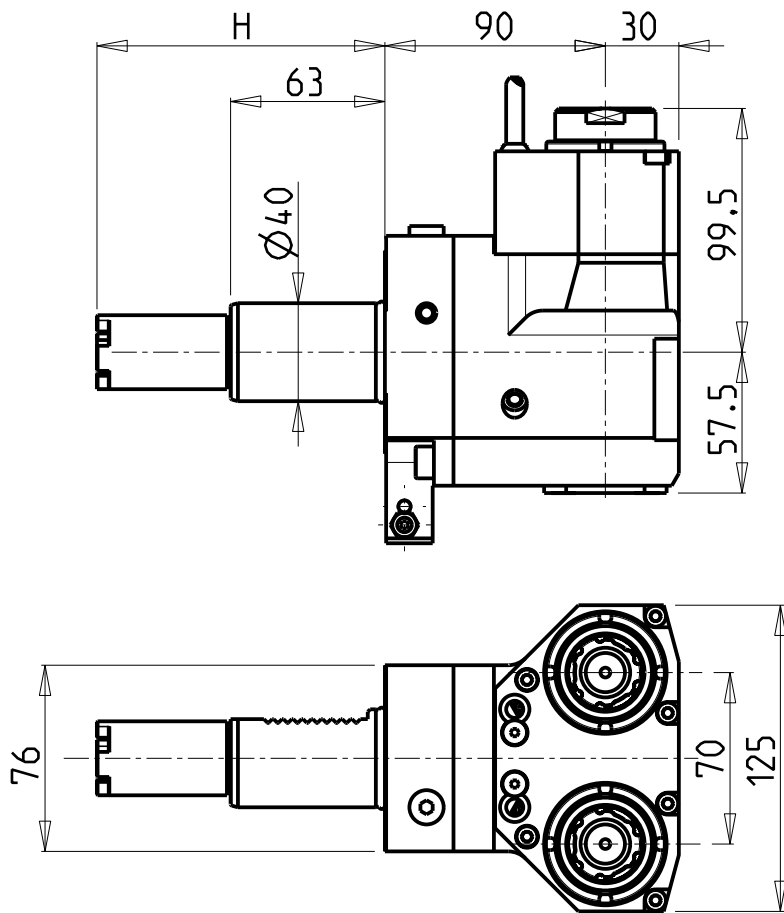

ATTENZIONE - ATTENTION - ACHTUNG

- Per lo smontaggio degli utensili utilizzare sempre la chiave di contrasto come indicato nel manuale d'uso.
- For disassembly of the tools use always the contrast key as mentioned in the user instructions.
- Fuer das Abmontieren der Werkzeuge immer den Gegenschlüssel benutzen wie in der Bedienungsanleitung erwäehnt.

- Chiave inclusa
- Key included
- Schlüessel inbegriffen

Cod. MT	Mandrino Spindle Spindel	I	RPM	Coppia Max Max Torque Max Drehmoment	N°Utensili N°Tools N°Werkzeuge	Lubrificazione int. Coolant through Innenkuehlung	Lubr.esterna Ext. coolant Aussenkuehlung	H	Tipo Torretta Turret type Revolver typ	CHIAVI NON INCLUSE Keys not included Schlüessel nicht einbegriffen		
										CHUB38	CHUB27	CHTAER25ZC
HAS0240125	ERA25	1:1	6000	50Nm	2		X	117.55	VDI STANDARD / HYBRID TURRET	CHUB38	CHUB27	CHTAER25ZC
HAS0240225	ERA25	1:1	6000	50Nm	2	P=70bar	X	117.55	VDI STANDARD / HYBRID TURRET	CHUB38	CHUB27	CHTAER25ZC

HAAS

MOD: ST10/20/25/30/35 - DS30

MODULO MOTORIZZATO RADIALE 2 USCITE IN Y VDI40

Radial single side twin head driven tool in Y VDI40

Radial angetriebenes Werkzeug 2 Ausgaenge in Y VDI40

Subject to change without notice.

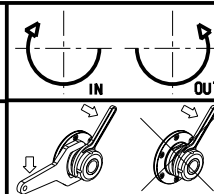

M.T. srl

Via Casino Albini 480
Tel. 0541/956034-957884
Fax 0541/956341

47842 S. GIOVANNI IN M. (RN)
e-mail: mtma@mtmarchetti.com
http://www.mtmarchetti.com

PRODUZIONE MODULI ROTANTI



PAGINA HAS263-3-10

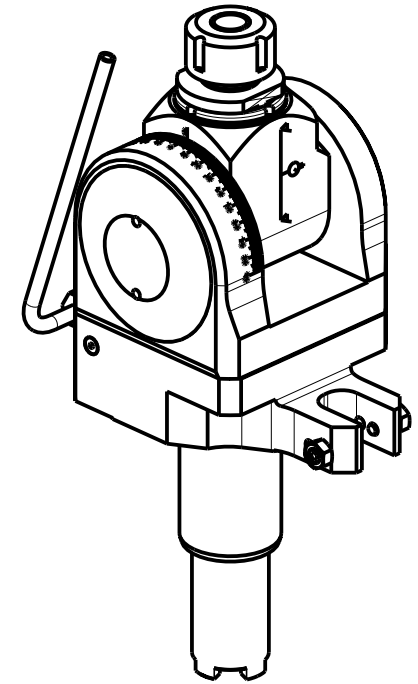
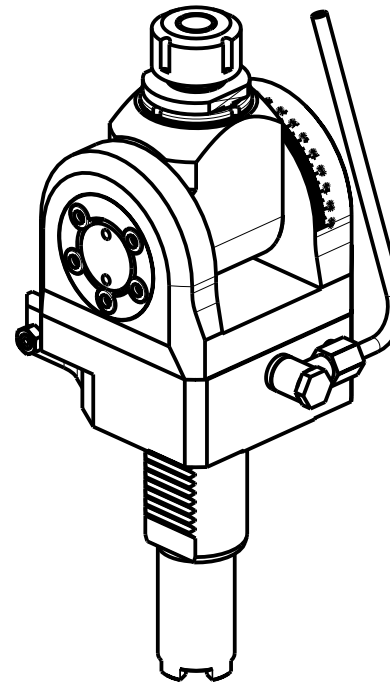
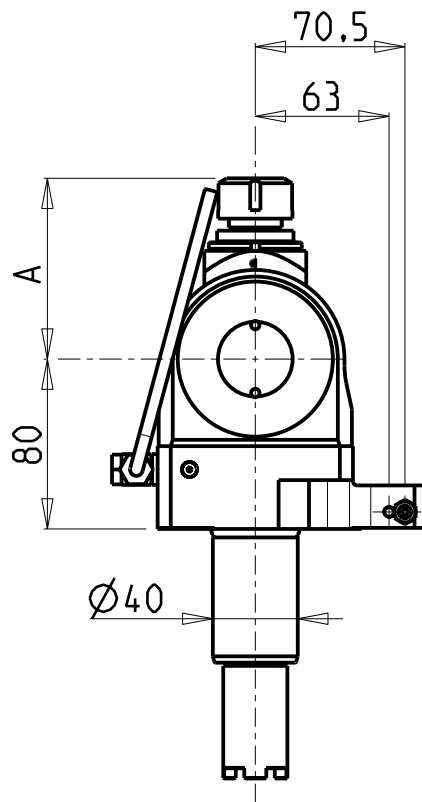
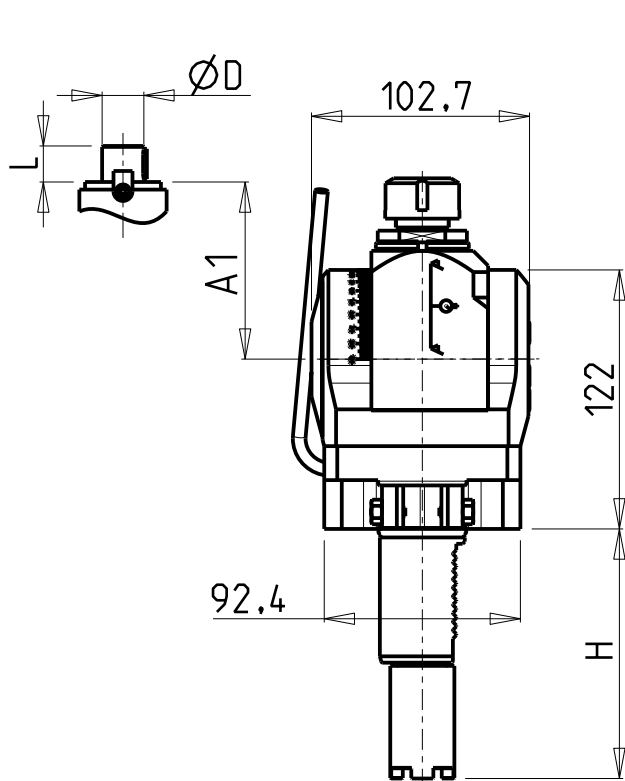

Cod. MT	Mandrino Spindle Spindel	I	RPM	Coppia Max Max Torque Max Drehmoment	Lubrificazione est. Ext. coolant Aussenkuehlung	A	A1	D	L	H	Tipo Torretta Turret Type Revolver Typ	CHIAVI INCLUDE Keys included Schluessel inbegriffen	
HAS0480120	ER20	1:1	6000	40Nm	X	85.16	-	-	-	117.55	VDI STANDARD / HYBRID TURRET	CHUB36	CHSTER20
HAS0480125	ER25	1:1	6000	40Nm	X	86.16	-	-	-	117.55	VDI STANDARD / HYBRID TURRET	CHUB36	CHSTER25
HAS0480516	Ø16x17	1:1	6000	40Nm	X	-	65	16	17	117.55	VDI STANDARD / HYBRID TURRET	CHUB36	CH_VTCROCE_M08
HAS0480522	Ø22x19	1:1	6000	40Nm	X	-	66	22	19	117.55	VDI STANDARD / HYBRID TURRET	CHUB36	CH_VTCROCE_M10
HAS0480519	Ø3/4"x3/4"	1:1	6000	40Nm	X	-	65	3/4"	3/4"	117.55	VDI STANDARD / HYBRID TURRET	CHUB36	CH_VTCROCE_M08

HAAS
 MOD: ST10/15/20/25/30/35 - DS30 - TL15/25

MODULO MOTORIZZATO ORIENTABILE ±90° VDI40
 ±90° adjustable angle driven tool VDI40
 Angetriebenes Werkzeug schwenkbar ±90° VDI40

Subject to change without notice.

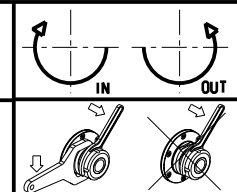

M.T. srl
 Via Casino Albini 480
 Tel. 0541/956034-957884
 Fax 0541/956341
 47842 S. GIOVANNI IN M. (RN)
 e-mail: mtma@mtmarchetti.com
 http://www.mtmarchetti.com

PRODUZIONE MODULI ROTANTI



PAGINA HAS333-3-00

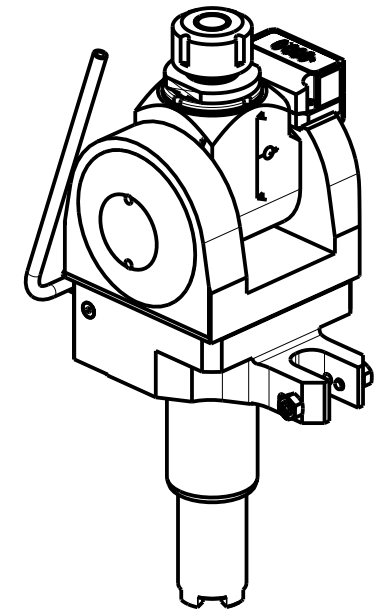
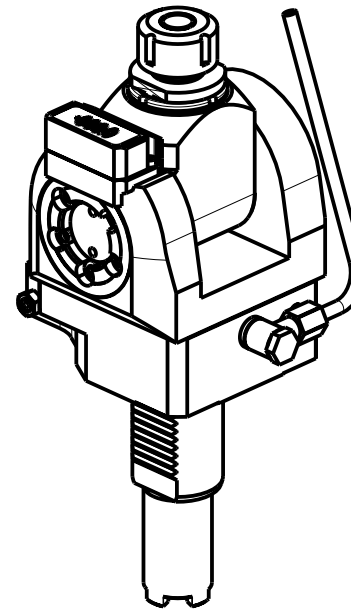
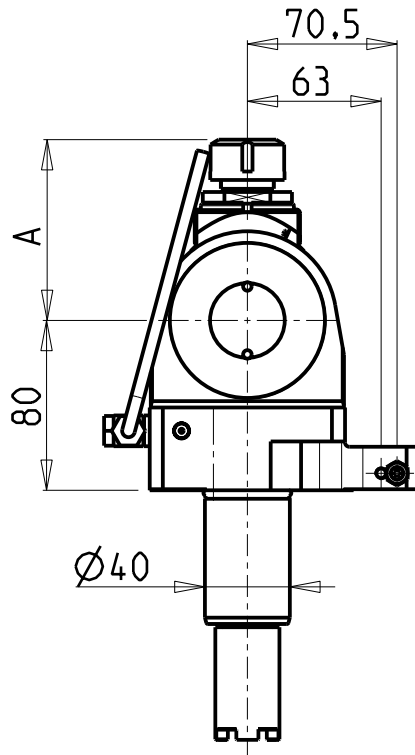
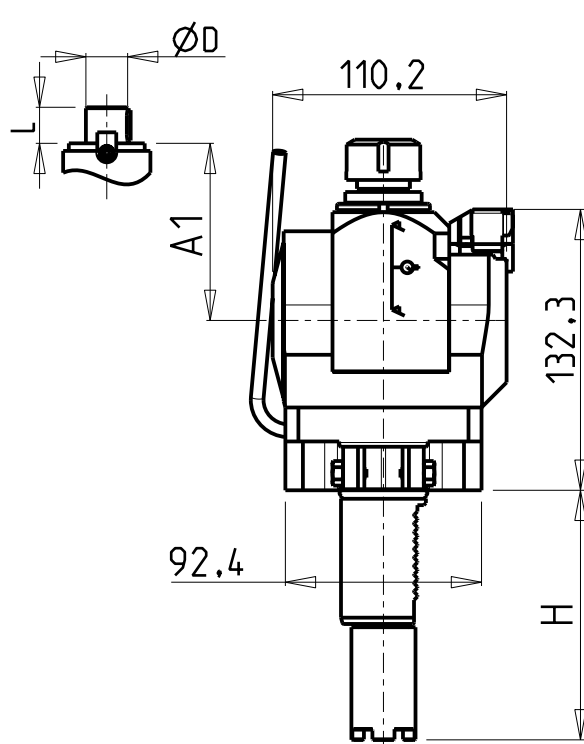

Cod. MT	Mandrino Spindle Spindel	I	RPM	Coppia Max Max Torque Max Drehmoment	Lubrificazione est. Ext. coolant Aussenkuehlung	A	A1	D	L	H	Tipo Torretta Turret Type Revolver Typ	CHIAVI INCLUDE Keys included Schluessel inbegriffen	
												CHUB36	CHSTER20
HAS0450120	ER20	1:1	6000	40Nm	X	85.16	-	-	-	117.55	VDI STANDARD / HYBRID TURRET	CHUB36	CHSTER20
HAS0450125	ER25	1:1	6000	40Nm	X	86.16	-	-	-	117.55	VDI STANDARD / HYBRID TURRET	CHUB36	CHSTER25
HAS0450516	Ø16x17	1:1	6000	40Nm	X	-	65	16	17	117.55	VDI STANDARD / HYBRID TURRET	CHUB36	CH_VTCROCE_M08
HAS0450522	Ø22x19	1:1	6000	40Nm	X	-	66	22	19	117.55	VDI STANDARD / HYBRID TURRET	CHUB36	CH_VTCROCE_M10
HAS0450519	Ø3/4"x3/4"	1:1	6000	40Nm	X	-	65	3/4"	3/4"	117.55	VDI STANDARD / HYBRID TURRET	CHUB36	CH_VTCROCE_M08

HAAS

MOD: ST10/15/20/25/30/35 - DS30 - TL15/25

MODULO MOTORIZZATO ORIENTABILE ±90° CON NONIO DIGITALE VD140
 ±90° adjustable angle driven tool with digital display VD140
 Angetriebenes Werkzeug schwenkbar ±90° mit digital display VD140

Subject to change without notice.

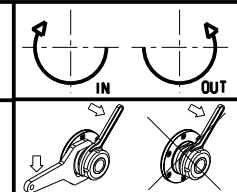

M.T. srl
 Via Casino Albini 480
 Tel. 0541/956034-957884
 Fax 0541/956341
 47842 S. GIOVANNI IN M. (RN)
 e-mail: mtma@mtmarchetti.com
 http://www.mtmarchetti.com

PRODUZIONE MODULI ROTANTI



PAGINA HAS333-3-01

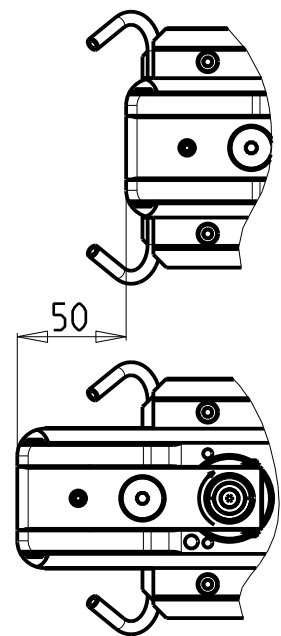
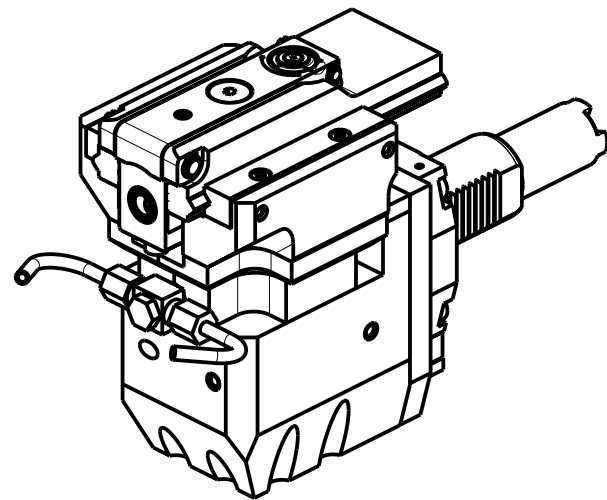
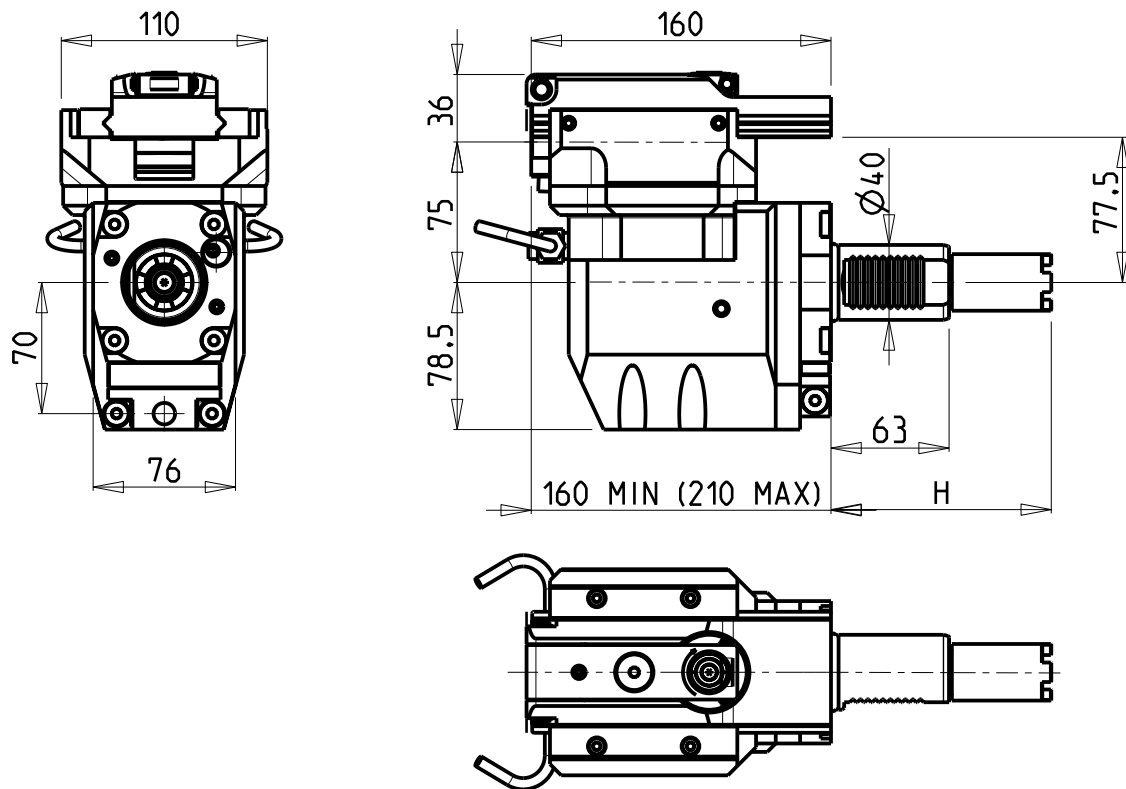

PER UTENSILI STOZZATORI VEDI PAG. TBL400-1-00
 FOR DRIVEN SLOTTING TOOL CUTTING-TOOLS SEE PAGE TBL400-1-00
 FÜR NUTENSTOSS-WERKZEUG SCHNEIDWERKZEUGE SIEHE SEITE TBL400-1-00

Cod. MT	I	RPM MAX	Lubr. esterna Ext. coolant Aussenkuehlung	H	Tipo Torretta Turret type Revolver typ
HAS0350100	4:1	2000	X	117.55	VDI STANDARD / HYBRID TURRET

HAAS
 MOD: ST10/15/20/25/30/35 - DS30 - TL15/25

MODULO MOTORIZZATO STOZZATORE CORSA 50mm VDI40
 Slotting driven tool 50mm stroke VDI40
 Keilnutenstossmaschine 50mm Hub VDI40

Subject to change without notice.

M.T. srl
 Via Casino Albini 480
 Tel. 0541/956034-957884
 Fax 0541/956341
 47842 S. GIOVANNI IN M. (RN)
 e-mail: mtma@mtmarchetti.com
 http://www.mtmarchetti.com

PRODUZIONE MODULI ROTANTI



PAGINA HAS360-3-30

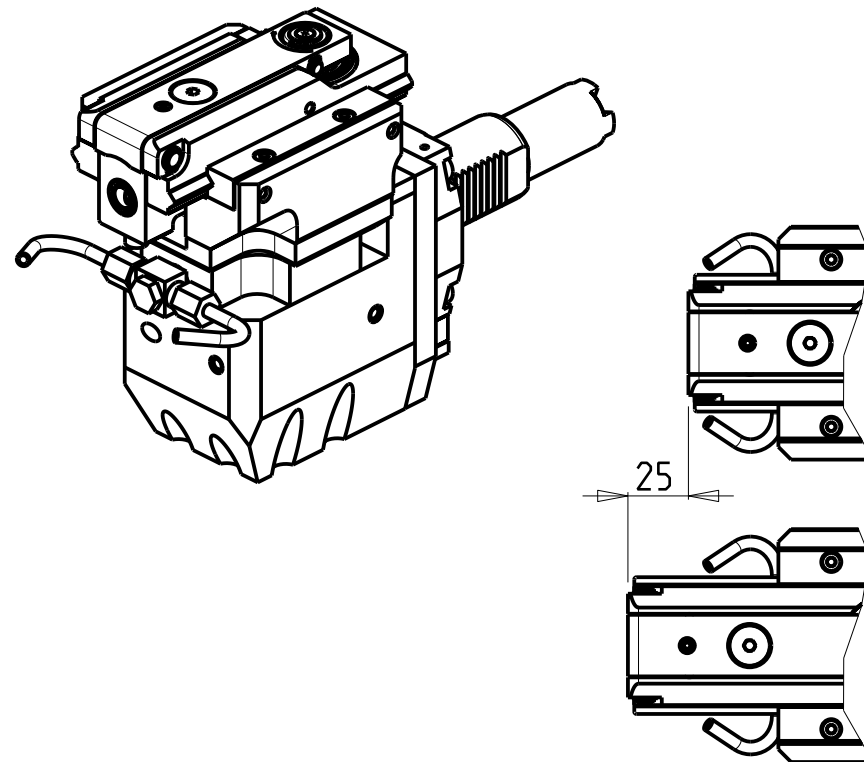
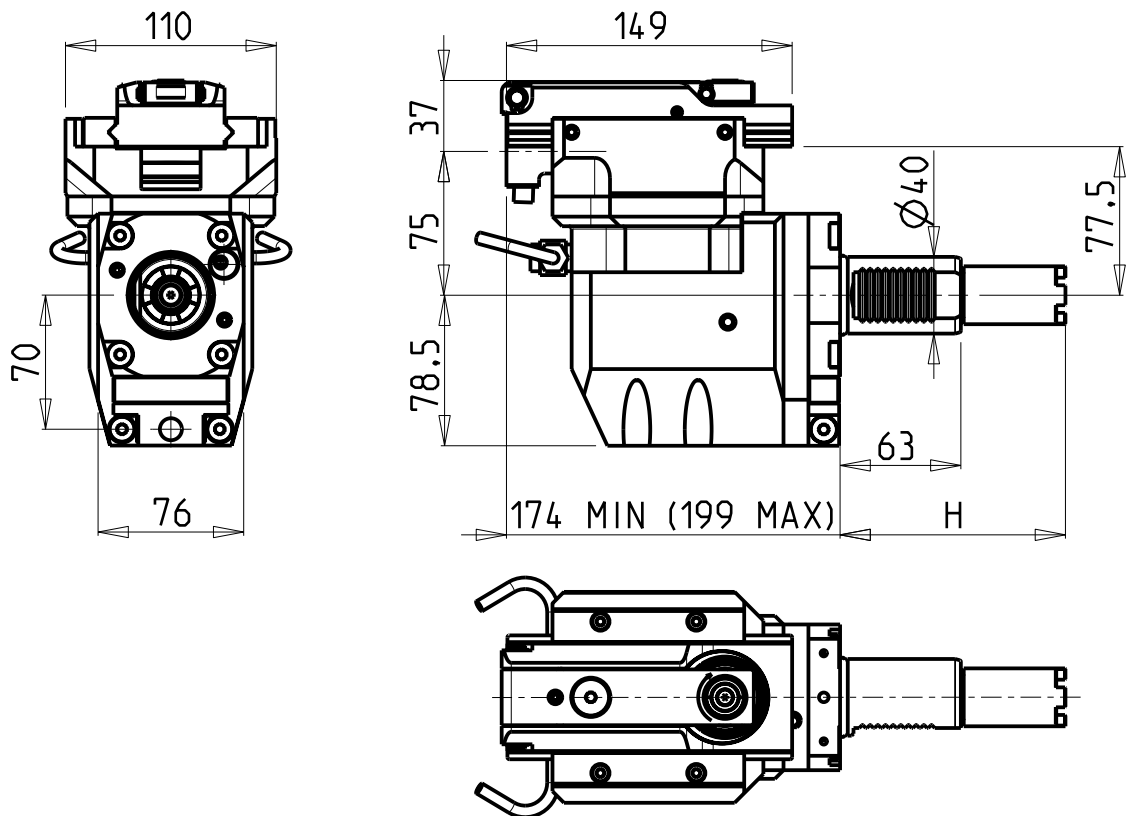

PER UTENSILI STOZZATORI VEDI PAG. TBL400-1-00
 FOR DRIVEN SLOTTING TOOL CUTTING-TOOLS SEE PAGE TBL400-1-00
 FÜR NUTENSTOSS-WERKZEUG SCHNEIDWERKZEUGE SIEHE SEITE TBL400-1-00

Cod. MT	I	RPM MAX	Lubr. esterna Ext. coolant Aussenkuehlung	H	Tipo Torretta Turret type Revolver typ
HAS0350200	4:1	2400	X	117,55	VDI STANDARD / HYBRID TURRET

HAAS

MOD: ST10/15/20/25/30/35 - DS30 - TL15/25

MODULO MOTORIZZATO STOZZATORE CORSA 25mm VDI40

Slotting driven tool 25mm stroke VDI40

Keilnutenstossmaschine 25mm Hub VDI40

Subject to change without notice.

M.T. srl

Via Casino Albini 480
 Tel. 0541/956034-957884
 Fax 0541/956341

47842 S. GIOVANNI IN M. (RN)
 e-mail: mtma@mtmarchetti.com
 http://www.mtmarchetti.com

PRODUZIONE MODULI ROTANTI



PAGINA HAS360-3-31

