

		PAGINA Page Seite
<b>MODULO MOTORIZZATO RADIALE</b> Radial driven tool Radial angetriebenes Werkzeug		GDW 010.5.00 NEW
<b>MODULO MOTORIZZATO ASSIALE H=65mm</b> Axial driven tool H=65mm Axial angetriebenes Werkzeug H=65mm		GDW 150.5.10 NEW
<b>MODULO MOTORIZZATO ORIENTABILE ±90°</b> ±90° adjustable angle driven tool Angetriebenes Werkzeug schwenkbar ±90°		GDW 335.5.00 NEW
<b>MODULO MOTORIZZATO ORIENTABILE ±90° CON NONIO DIGITALE</b> ±90° adjustable angle driven tool with digital display Angetriebenes Werkzeug schwenkbar ±90° mit digital display		GDW 335.5.01 NEW
<b>MODULO MOTORIZZATO ORIENTABILE ±90° MOLTIPLICATO I=1:2</b> ±90° adjustable angle driven tool geared-up I=1:2 Angetriebenes Werkzeug schwenkbar ±90° uebersetzt I=1:2		GDW 336.5.00 NEW
<b>MOD. MOTORIZZ. ORIENTABILE ±90° MOLTIPL. I=1:2 CON NONIO DIGITALE</b> ±90° adjustable angle driven tool geared-up I=1:2 with digital display Angetriebenes Werkzeug schwenkbar ±90° uebersetzt I=1:2 mit digital display		GDW 336.5.01 NEW
<b>MODULO MOTORIZZATO STOZZATORE CORSA 50mm H=85mm</b> Slotting driven tool 50mm stroke H=85mm Keilnutenstossmaschine 50mm Hub H=85mm		GDW 360.5.00 NEW
<b>MODULO MOTORIZZATO STOZZATORE CORSA 25mm H=85mm</b> Slotting driven tool 25mm stroke H=85mm Keilnutenstossmaschine 25mm Hub H=85mm		GDW 360.5.01 NEW

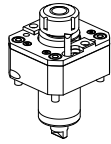

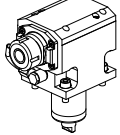
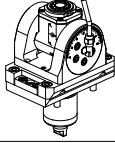
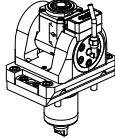
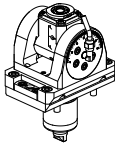
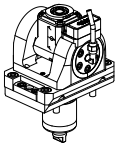
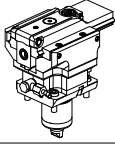
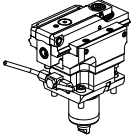
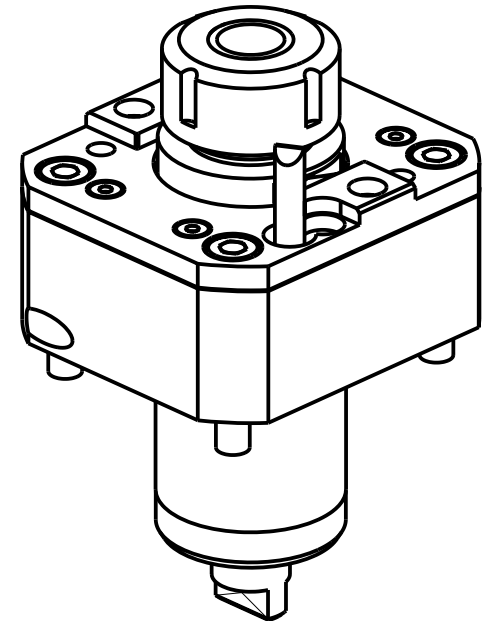
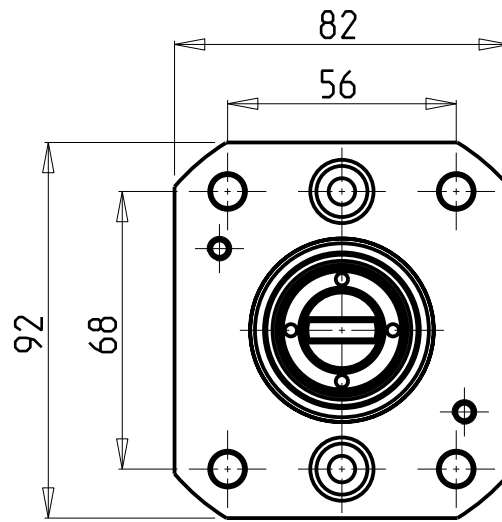
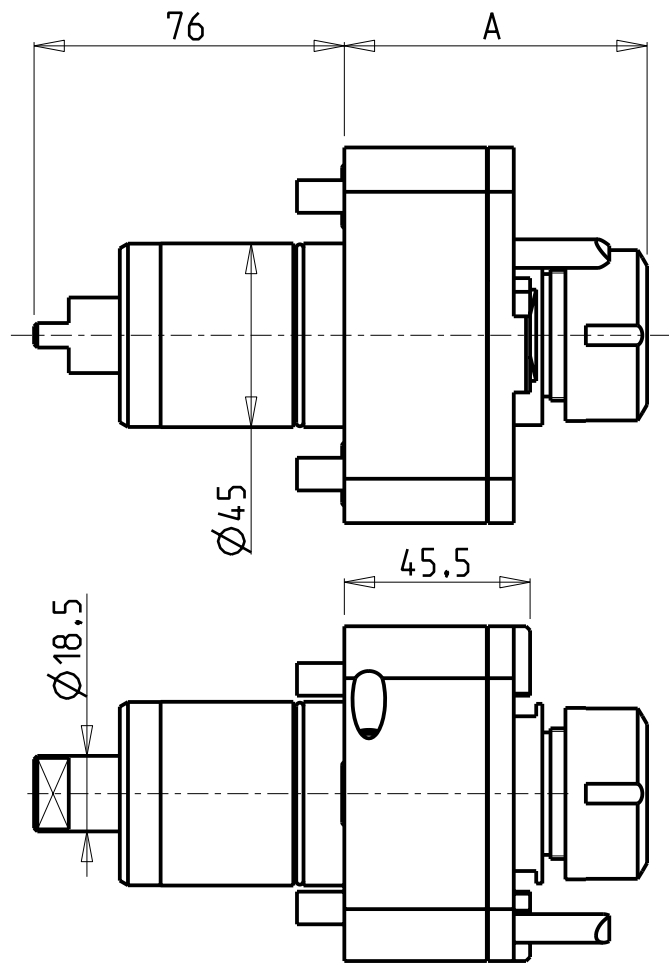

Cod. MT	Mandrino Spindle Spindel	I	RPM	Coppia Max Max Torque Max Drehmoment	Lubrificazione est. Ext. coolant Aussehenkuehlung	A	CHIAVI NON INCLUSE Keys not included Schluessel nicht inbegriffen		
MYA0100125	ER25	1:1	6000	40Nm	X	74.2	-	CHSTER25	OKU0290009
MYA0100325	ERA25	1:1	6000	40Nm	X	51	CHUB27	CHTAER25ZC	OKU0290009

- Chiave inclusa
- Key included
- Schluessel inbegriffen

NEW  
NEW

**GOODWAY**  
 MOD: GLS-150/200M/Y - GLS-1500/2000M - GTS-150MMX/XY - GTW-1500

MODULO MOTORIZZATO RADIALE  
 Radial driven tool  
 Radial angetriebenes Werkzeug

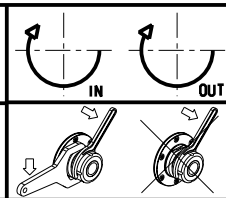

**M.T. srl**  
 Via Casino Albini 480  
 Tel. 0541/956034-957884  
 Fax 0541/956341  
 47842 S. GIOVANNI IN M. (RN)  
 e-mail: mtma@mtmarchetti.com  
 http://www.mtmarchetti.com

PRODUZIONE MODULI ROTANTI



PAGINA GDW010-5-00

Subject to change without notice.

10/2018

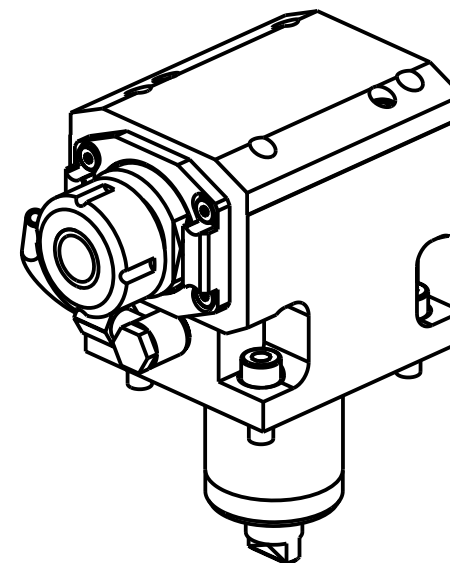
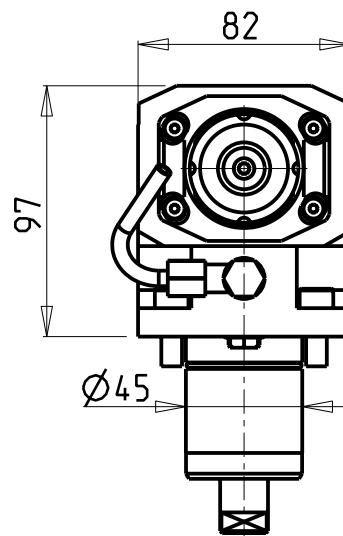
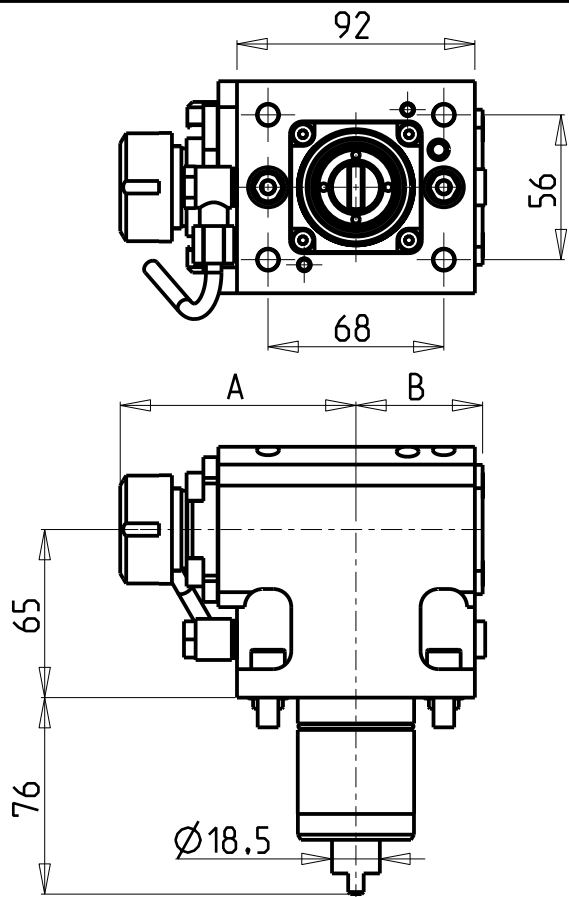

- Chiave inclusa
- Key included
- Schlüssel inbegriffen

Cod. MT	Mandrino Spindel Spindel	I	RPM	Coppia Max Max Torque Max Drehmoment	Reversibile lato mandrino/controlmandrino Reversible sub/main spindle side Umkehrbare Spindel-seite/ Gegenspindel-seite	Lubrificazione int. Coolant through Innenkuehlung	Lubrificazione est. Ext. coolant Aussenkuehlung	A	B	CHIAVI NON INCLUSE Keys not included Schlüssel nicht inbegriffen			
MYA0110125	ER25	1:1	6000	40Nm	X	-	X	91.2	49	-	CHSTER25	OKU0290009	NEW
MYA0110225	ER25	1:1	6000	40Nm	X	P=70bar	X	91.2	60	-	CHSTER25	OKU0290009	NEW
MYA0110325	ERA25	1:1	6000	40Nm	X	-	X	72.5	49	CHUB27	CHTAER25ZC	OKU0290009	NEW
MYA0110425	ERA25	1:1	6000	40Nm	X	P=70bar	X	72.5	60	CHUB27	CHTAER25ZC	OKU0290009	NEW

GOODWAY

MOD: GLS-150/200M/Y - GLS-1500/2000M - GTS-150MMX/XY - GTW-1500

MODULO MOTORIZZATO ASSIALE H=65mm

Axial driven tool H=65mm

Axial angetriebenes Werkzeug H=65mm

Subject to change without notice.

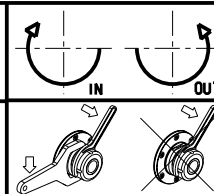

**M.T. srl**

Via Casino Albini 480  
Tel. 0541/956034-957884  
Fax 0541/956341

47842 S. GIOVANNI IN M. (RN)  
e-mail: mtma@mtmarchetti.com  
http://www.mtmarchetti.com

PRODUZIONE MODULI ROTANTI



PAGINA GDW 150-5-10

**ATTENZIONE - ATTENTION - ACHTUNG**

- Per lo smontaggio degli utensili utilizzare sempre la chiave di contrasto come indicato nel manuale d'uso.
- For disassembly of the tools use always the contrast key as mentioned in the user instructions.
- Fuer das Abmontieren der Werkzeuge immer den Gegenschlüssel benutzen wie in der Bedienungsanleitung erwäehnt.

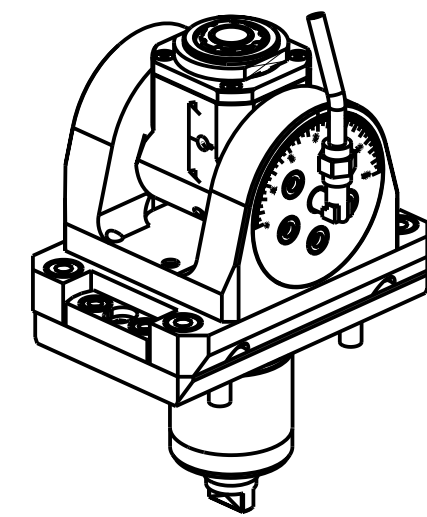
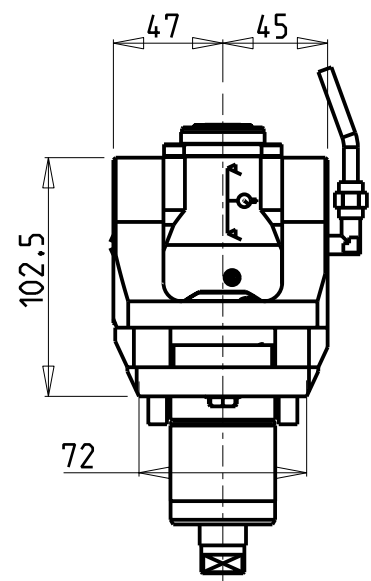
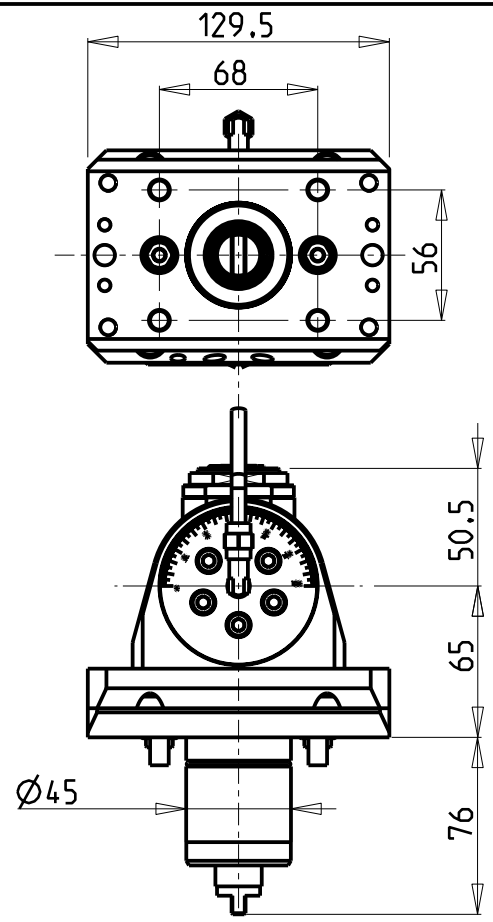

Cod. MT	Mandrino Spindle Spindel	I	RPM	Coppia Max Max Torque Max Drehmoment	Reversibile lato mandrino/contromandrino Reversible sub/main spindle side Umkehrbare Spindel-seite/ Gegenspindel-seite	Lubrificazione int. Coolant through Innenkuehlung	Lubrificazione est. Ext. coolant Aussenkuehlung	CHIAVI INCLUSE Keys included Schluessel inbegriffen				
								CHUB36	CHUB22	CHESL06	CHTAER20ZC	
MYA0080120	ERA20	1:1	6000	30Nm	X	-	X	CHUB36	CHUB22	CHESL06	CHTAER20ZC	NEW
MYA0080220	ERA20	1:1	6000	30Nm	X	P=70bar	X	CHUB36	CHUB22	CHESL06	CHTAER20ZC	NEW

**GOODWAY**  
 MOD: GLS-150/200M/Y - GLS-1500/2000M - GTS-150MMX/XY - GTW-1500

MODULO MOTORIZZATO ORIENTABILE ±90°  
 ±90° adjustable angle driven tool  
 Angetriebenes Werkzeug schwenkbar ±90°

Subject to change without notice.

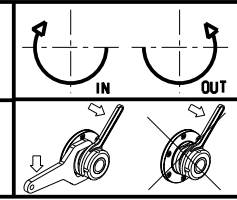

**M.T. srl**  
 Via Casino Albini 480  
 Tel. 0541/956034-957884  
 Fax 0541/956341  
 47842 S. GIOVANNI IN M. (RN)  
 e-mail: mtma@mtmarchetti.com  
 http://www.mtmarchetti.com

PRODUZIONE MODULI ROTANTI



PAGINA GDW 335-5-00

**ATTENZIONE - ATTENTION - ACHTUNG**

- Per lo smontaggio degli utensili utilizzare sempre la chiave di contrasto come indicato nel manuale d'uso.
- For disassembly of the tools use always the contrast key as mentioned in the user instructions.
- Fuer das Abmontieren der Werkzeuge immer den Gegenschlüssel benutzen wie in der Bedienungsanleitung erwaehnt.

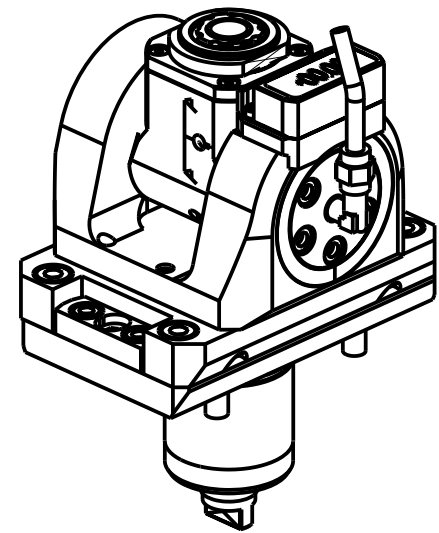
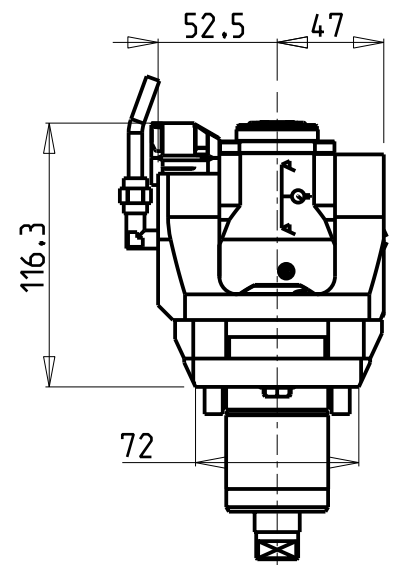
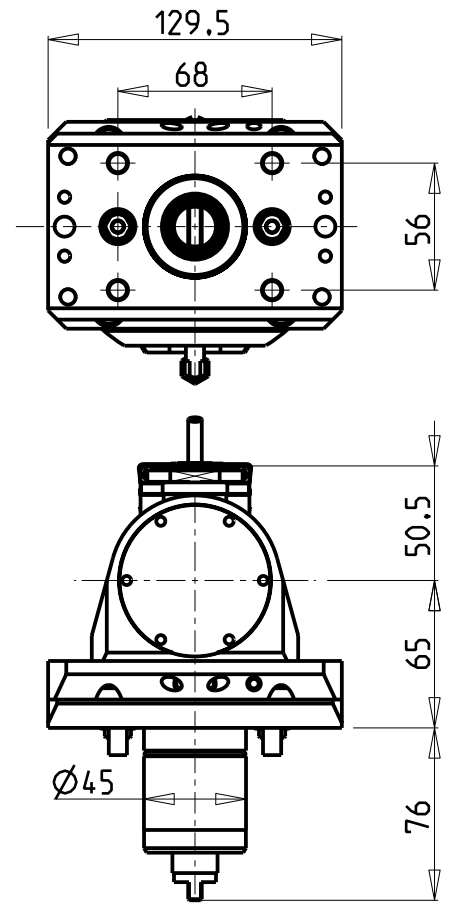

Cod. MT	Mandrino Spindle Spindel	I	RPM	Coppia Max Max Torque Max Drehmoment	Reversibile lato mandrino/contromandrino Reversible sub/main spindle side Umkehrbare Spindel-seite/ Gegenspindel-seite	Lubrificazione int. Coolant through Innenkuehlung	Lubrificazione est. Ext. coolant Aussenkuehlung	CHIAVI INCLUSE Keys included Schluessel inbegriffen				
					X	-	X	CHUB36	CHUB22	CHESL06	CHTAER20ZC	
MYA0085120	ERA20	1:1	6000	30Nm	X	-	X	CHUB36	CHUB22	CHESL06	CHTAER20ZC	NEW
MYA0085220	ERA20	1:1	6000	30Nm	X	P=70bar	X	CHUB36	CHUB22	CHESL06	CHTAER20ZC	NEW

**GOODWAY**  
 MOD: GLS-150/200M/Y - GLS-1500/2000M - GTS-150MMX/XY - GTW-1500

MODULO MOTORIZZATO ORIENTABILE ±90° CON NONIO DIGITALE  
 ±90° adjustable angle driven tool with digital display  
 Angetriebenes Werkzeug schwenkbar ±90° mit digital display

Subject to change without notice.

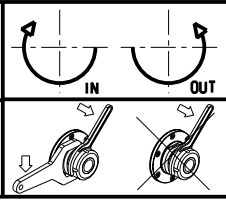

**M.T. srl**  
 Via Casino Albini 480  
 Tel. 0541/956034-957884  
 Fax 0541/956341  
 47842 S. GIOVANNI IN M. (RN)  
 e-mail: mtma@mtmarchetti.com  
 http://www.mtmarchetti.com

PRODUZIONE MODULI ROTANTI

PAGINA GDW 335-5-01

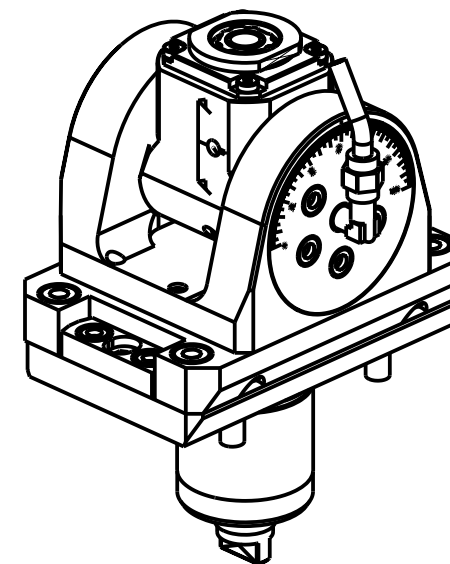
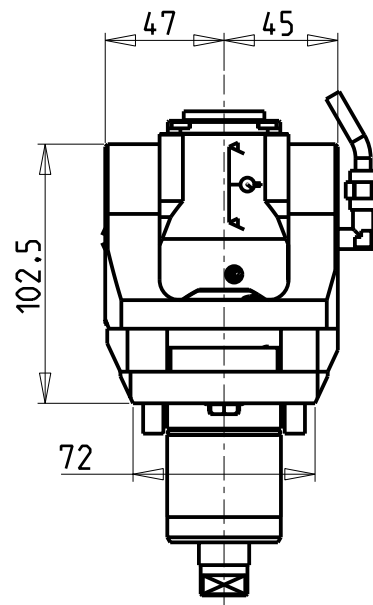
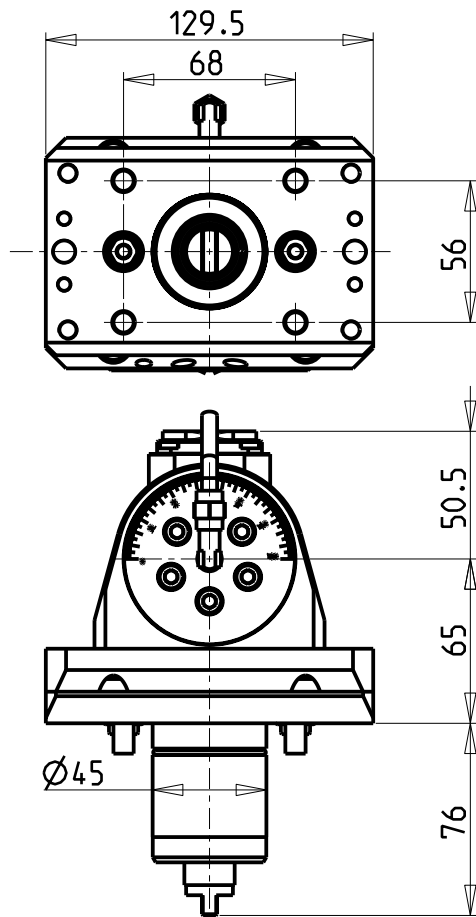

### ATTENZIONE - ATTENTION - ACHTUNG

- Per lo smontaggio degli utensili utilizzare sempre la chiave di contrasto come indicato nel manuale d'uso.
- For disassembly of the tools use always the contrast key as mentioned in the user instructions.
- Fuer das Abmontieren der Werkzeuge immer den Gegenschlüssel benutzen wie in der Bedienungsanleitung erwaeht.

Cod. MT	Mandrino Spindle Spindel	I	RPM	Coppia Max Max Torque Max Drehmoment	Reversibile lato mandrino/contromandrino Reversible sub/main spindle side Umkehrbare Spindel-seite/ Gegenspindel-seite	Lubrificazione int. Coolant through Innenkuehlung	Lubrificazione est. Ext. coolant Aussenkuehlung	CHIAVI INCLUSE Keys included Schlüssel inbegriffen				
					X	-	X	CHUB19_SP3	CHUB32	CHESL06	CHTAER16ZC	
MYA0080316	ERA16	1:2	12000	8Nm	X	-	X	CHUB19_SP3	CHUB32	CHESL06	CHTAER16ZC	NEW
MYA0080416	ERA16	1:2	12000	8Nm	X	P=70bar	X	CHUB19_SP3	CHUB32	CHESL06	CHTAER16ZC	NEW

GOODWAY

MOD: GLS-150/200M/Y - GLS-1500/2000M - GTS-150MMX/XY - GTW-1500

MODULO MOTORIZZATO ORIENTABILE +/-90° MOLTIPLICATO I=1:2

+/-90° adjustable angle driven tool geared-up I=1:2

Angetriebenes Werkzeug schwenkbar +/-90° uebersetzt I=1:2

Subject to change without notice.

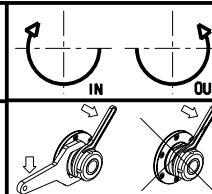

**M.T. srl**

Via Casino Albini 480  
Tel. 0541/956034-957884  
Fax 0541/956341  
47842 S. GIOVANNI IN M. (RN)  
e-mail: mtma@mtmarchetti.com  
http://www.mtmarchetti.com

PRODUZIONE MODULI ROTANTI



PAGINA GDW 336-5-00

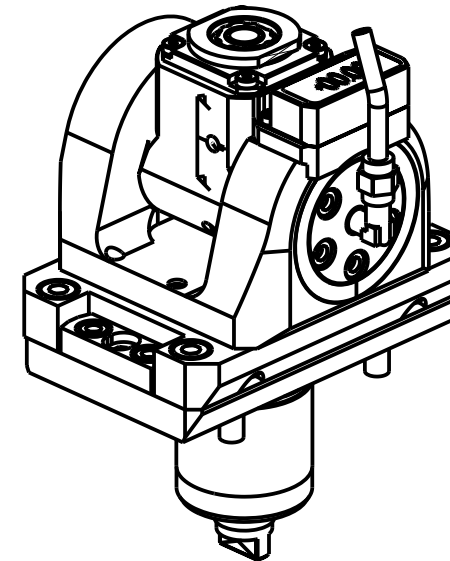
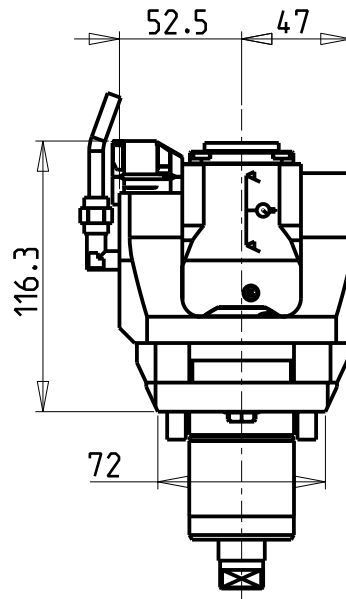
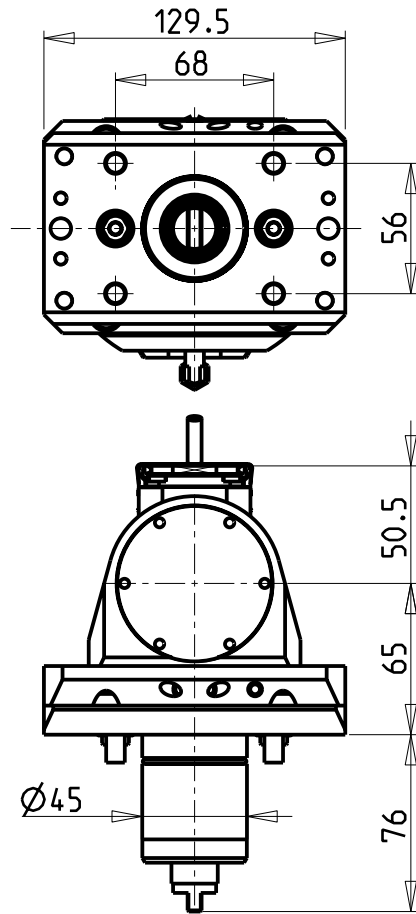

### ATTENZIONE - ATTENTION - ACHTUNG

- Per lo smontaggio degli utensili utilizzare sempre la chiave di contrasto come indicato nel manuale d'uso.
- For disassembly of the tools use always the contrast key as mentioned in the user instructions.
- Fuer das Abmontieren der Werkzeuge immer den Gegenschlüssel benutzen wie in der Bedienungsanleitung erwäehnt.

Cod. MT	Mandrino Spindle Spindel	I	RPM	Coppia Max Max Torque Max Drehmoment	Reversibile lato mandrino/contromandrino	Lubrificazione int. Coolant through Innenkuehlung	Lubrificazione est. Ext. coolant Aussenkuehlung	CHIAVI INCLUSE Keys included Schlüssel inbegriffen				
					Reversible sub/main spindle side Umkehrbare Spindel-seite/ Gegenspindel-seite			CHUB19_SP3	CHUB32	CHESL06	CHTAER16ZC	
MYA0085316	ERA16	1:2	12000	8Nm	X	-	X	CHUB19_SP3	CHUB32	CHESL06	CHTAER16ZC	NEW
MYA0085416	ERA16	1:2	12000	8Nm	X	P=70bar	X	CHUB19_SP3	CHUB32	CHESL06	CHTAER16ZC	NEW

GOODWAY

MOD: GLS-150/200M/Y - GLS-1500/2000M - GTS-150MMX/XY - GTW-1500

MODULO MOTORIZZATO ORIENTABILE +/-90° MOLTIPLICATO I=1:2 CON NONIO DIGITALE

+/-90° adjustable angle driven tool geared-up I=1:2 with digital display

Angetriebenes Werkzeug schwenkbar +/-90° uebersetzt I=1:2 mit digital display

Subject to change without notice.

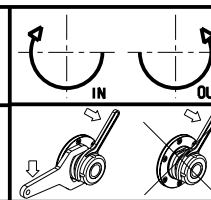

**M.T. srl**

Via Casino Albini 480  
Tel. 0541/956034-957884  
Fax 0541/956341  
47842 S. GIOVANNI IN M. (RN)  
e-mail: mtma@mtmarchetti.com  
http://www.mtmarchetti.com

PRODUZIONE MODULI ROTANTI



PAGINA GDW 336-5-01



**ATTENZIONE - ATTENTION - ACHTUNG**

- VERIFICARE LE MISURE DI INGOMBRO PER POSSIBILE INTERFERENZA SU ALCUNI MODELLI DI MACCHINE
- Please check the overall sizes for possible interferences on some machine models
- Bitte überprüfen sie das ausmass um mögliche interferenzen auf einigen maschinen modellen zu vermeiden

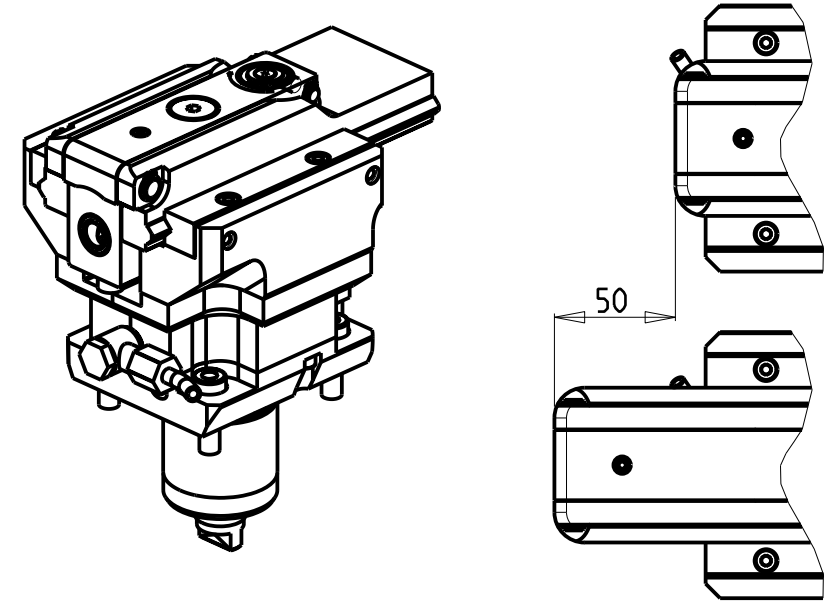
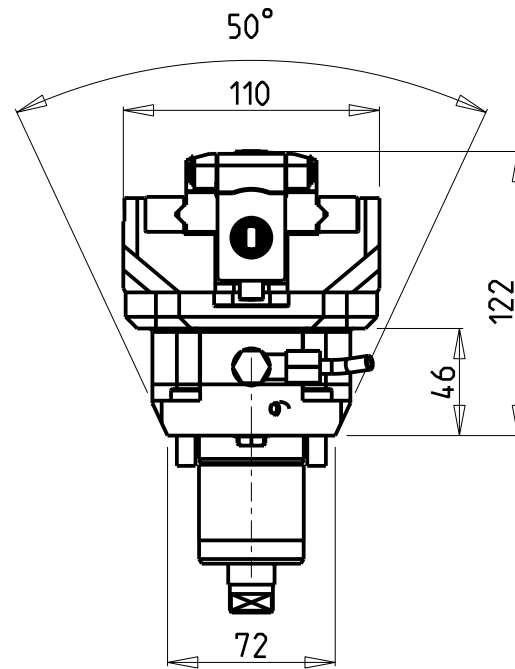
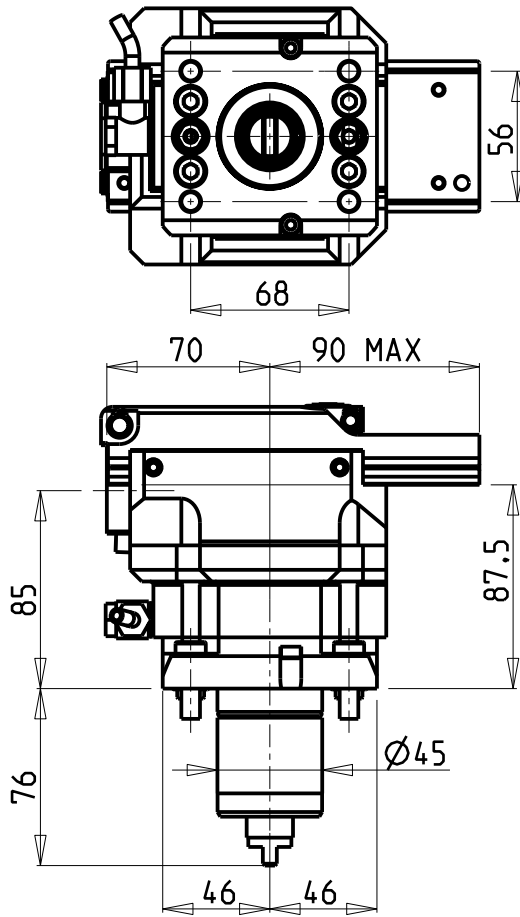

PER UTENSILI STOZZATORI VEDI PAG. TBL400-1-00  
 FOR DRIVEN SLOTTING TOOL CUTTING-TOOLS SEE PAGE TBL400-1-00  
 FÜR NUTENSTOSS-WERKZEUG SCHNEIDWERKZEUGE SIEHE SEITE TBL400-1-00

Cod. MT	I	RPM MAX	Reversibile lato mandrino/contromandrino Reversible sub/main spindle side Umkehrbare Spindel-seite/ Gegenspindel-seite	Lubr. esterna Ext. coolant Aussenkuehlung
MYA0050100	4:1	2000	X	X

NEW

GOODWAY

MOD: GLS-150/200M/Y - GLS-1500/2000M - GTS-150MMX/XY - GTW-1500

MODULO MOTORIZZATO STOZZATORE CORSA 50mm H=85mm

Slotting driven tool 50mm stroke H=85mm

Keilnutenstossmaschine 50mm Hub H=85mm

Subject to change without notice.

**M.T. srl**

Via Casino Albini 480  
 Tel. 0541/956034-957884  
 Fax 0541/956341  
 47842 S. GIOVANNI IN M. (RN)  
 e-mail: mtma@mtmarchetti.com  
 http://www.mtmarchetti.com

PRODUZIONE MODULI ROTANTI



PAGINA GDW 360-5-00

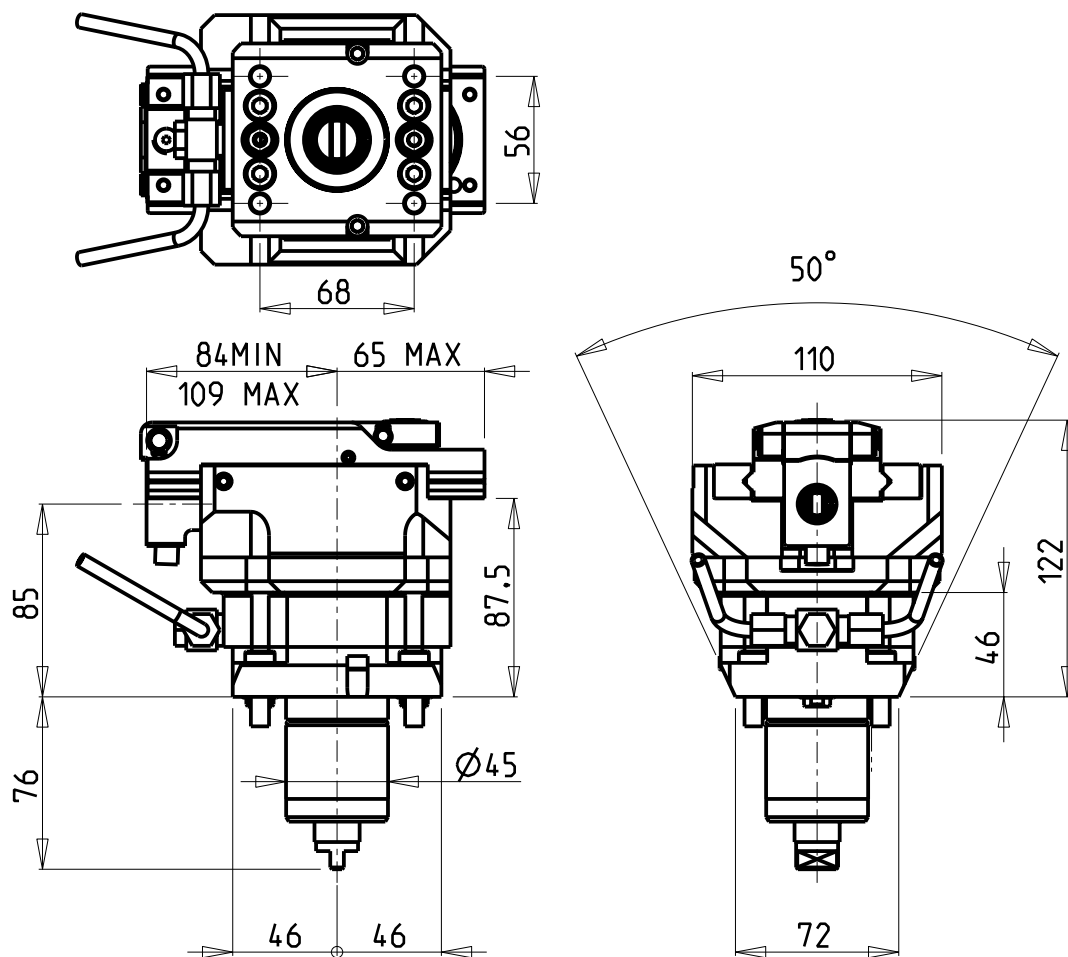

**ATTENZIONE - ATTENTION - ACHTUNG**

- VERIFICARE LE MISURE DI INGOMBRO PER POSSIBILE INTERFERENZA SU ALCUNI MODELLI DI MACCHINE
- Please check the overall sizes for possible interferences on some machine models
- Bitte überprüfen sie das ausmass um mögliche interferenzen auf einigen maschinen modellen zu vermeiden

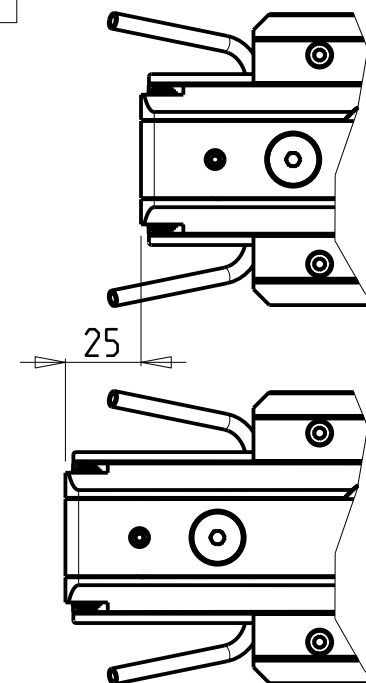
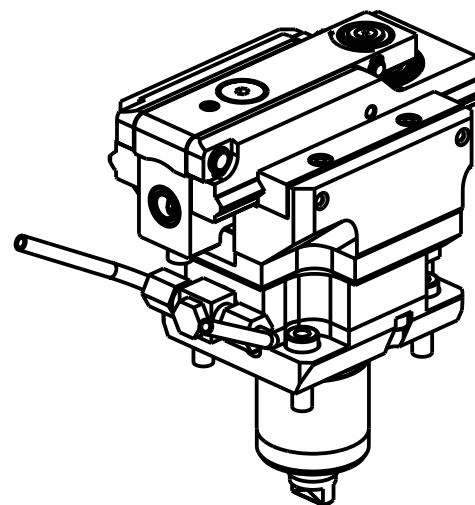

PER UTENSILI STOZZATORI VEDI PAG. TBL400-1-00  
 FOR DRIVEN SLOTTING TOOL CUTTING-TOOLS SEE PAGE TBL400-1-00  
 FÜR NUTENSTOSS-WERKZEUG SCHNEIDWERKZEUGE SIEHE SEITE TBL400-1-00

Cod. MT	I	RPM MAX	Reversibile lato mandrino/contromandrino Reversible sub/main spindle side Umkehrbare Spindel-seite/ Gegenspindel-seite	Lubr. esterna Ext. coolant Aussenkuehlung
MYA0050200	4:1	2400	X	X

NEW

GOODWAY

MOD: GLS-150/200M/Y - GLS-1500/2000M - GTS-150MMX/XY - GTW-1500

MODULO MOTORIZZATO STOZZATORE CORSA 25mm H=85mm

Slotting driven tool 25mm stroke H=85mm

Keilnutenstossmaschine 25mm Hub H=85mm

Subject to change without notice.

**M.T. srl**

Via Casino Albini 480  
 Tel. 0541/956034-957884  
 Fax 0541/956341  
 47842 S. GIOVANNI IN M. (RN)  
 e-mail: mtma@mtmarchetti.com  
 http://www.mtmarchetti.com

PRODUZIONE MODULI ROTANTI



PAGINA GDW 360-5-01