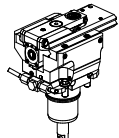
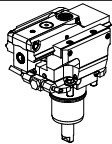
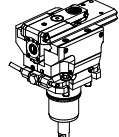
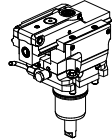
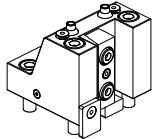
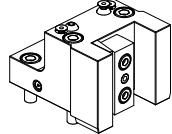
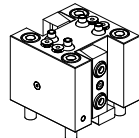
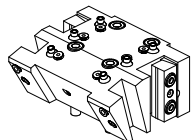
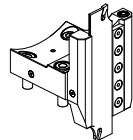
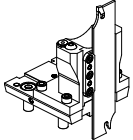
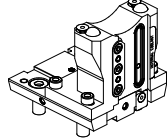
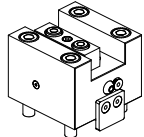
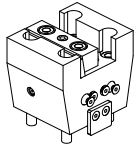
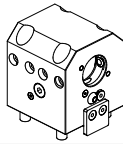
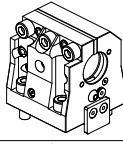
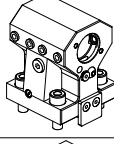
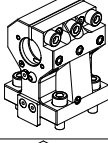
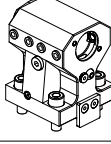
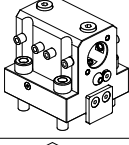
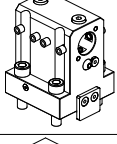
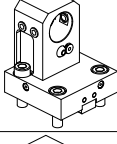
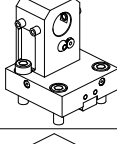
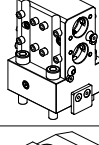
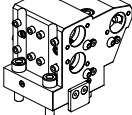

		PAGINA Page Seite
<p>MODULO MOTORIZZATO RADIALE ALTA PRESSIONE Radial driven tool high pressure Radial angetriebenes Werkzeug hochdruck</p>		CMZ010.3.20
<p>MODULO MOTORIZZATO RADIALE Radial driven tool Radial angetriebenes Werkzeug</p>		CMZ020.3.00
<p>MODULO MOTORIZZATO RADIALE MTSK Radial MTSK driven tool Radial MTSK angetriebenes Werkzeug</p>		CMZ020.3.00.K
<p>MODULO MOTORIZZATO RADIALE MOLTIPLICATO 1=1:3 Radial geared-up 1=1:3 driven tool Radial angetriebenes Werkzeug uebersetzt 1=1:3</p>		CMZ055.3.00
<p>MODULO MOTORIZZATO RADIALE 2 USCITE IN Y Radial single side twin head driven tool in Y Radial angetriebenes Werkzeug 2 Ausgaenge in Y</p>		CMZ090.3.00
<p>MODULO MOTORIZZATO RADIALE DISASSATO 30mm ORIENTABILE ±30° Radial ±30°adjustable angle driven tool re-directed by 30mm Radial angetriebenes Werkzeug schwenkbar ±30° achsversetzt um 30mm</p>		CMZ135.3.00
<p>MODULO MOTORIZZATO ASSIALE H=55mm Axial driven tool H=55mm Axial angetriebenes Werkzeug H=55mm</p>		CMZ150.3.10
<p>MODULO MOTORIZZATO ASSIALE H=75mm Axial driven tool H=75mm Axial angetriebenes Werkzeug H=75mm</p>		CMZ150.3.20
<p>MODULO MOTORIZZATO ASSIALE H=75mm Axial driven tool H=75mm Axial angetriebenes Werkzeug H=75mm</p>		CMZ150.3.21
<p>MODULO MOTORIZZATO ASSIALE MTSK H=75mm Axial MTSK driven tool H=75mm Axial MTSK angetriebenes Werkzeug H=75mm</p>		CMZ150.3.21.K
<p>MODULO MOTORIZZATO ASSIALE MAGGIORATO H=55mm Axial reinforced driven tool H=55mm Axial angetriebenes Werkzeug vengroessert H=55mm</p>		CMZ170.3.10

		PAGINA Page Seite
<p>MODULO MOTORIZZATO ASSIALE MAGGIORATO MTSK H=55mm Axial MTSK reinforced driven tool H=55mm Axial MTSK angetriebenes Werkzeug vergrößert H=55mm</p>		CMZ170.3.10.K
<p>MODULO MOTORIZZATO ASSIALE MAGGIORATO H=75mm Axial reinforced driven tool H=75mm Axial angetriebenes Werkzeug vergrößert H=75mm</p>		CMZ170.3.20
<p>MODULO MOTORIZZATO ASSIALE MAGGIORATO MTSK H=75mm Axial MTSK reinforced driven tool H=75mm Axial MTSK angetriebenes Werkzeug vergrößert H=75mm</p>		CMZ170.3.20.K
<p>MODULO MOTORIZZATO ASSIALE ARRETRATO H=75mm Axial rear-set driven tool H=75mm Axial angetriebenes Werkzeug zurueckversetzt H=75mm</p>		CMZ180.3.10
<p>MODULO MOTORIZZATO RADIALE ARRETRATO MTSK H=75mm Axial MTSK rear-set driven tool H=75mm Axial MTSK angetriebenes Werkzeug zurueckversetzt H=75mm</p>		CMZ180.3.10.K
<p>MODULO MOTORIZZATO ASSIALE MOLTIPLICATO I=1:3 H=55mm Axial geared-up I=1:3 driven tool H=55mm Axial angetriebenes Werkzeug uebersetzt I=1:3 H=55mm</p>		CMZ205.3.10
<p>MODULO MOTORIZZATO ASSIALE MOLTIPLICATO I=1:3 H=75mm Axial geared-up I=1:3 driven tool H=75mm Axial angetriebenes Werkzeug uebersetzt I=1:3 H=75mm</p>		CMZ205.3.20
<p>MODULO MOTORIZZATO ASSIALE PER POLIGONATURA INTERNA H=55mm Axial driven tool for internal polygon-making H=55mm Axial angetriebenes Werkzeug fuer interne Facettierung H=55mm</p>		CMZ230.3.10
<p>MODULO MOTORIZZATO ASSIALE PER POLIGONATURA INTERNA H=75mm Axial driven tool for internal polygon-making H=75mm Axial angetriebenes Werkzeug fuer interne Facettierung H=75mm</p>		CMZ230.3.20
<p>MODULO MOTOR. ASSIALE 2 USCITE IN Y PER POLIGONAT. INTERNA H=75mm Axial single side twin head driven tool in Y for internal polygon-making H=75mm Axial angetriebenes Werkzeug 2 Ausgange in Y fuer interne Facettierung H=75mm</p>		CMZ233.3.10
<p>MODULO MOTORIZZATO ASSIALE BISPORGENTE H=55mm Axial opposite face twin driven tool H=55mm Axial angetriebenes Werkzeug halb vorspringend H=55mm</p>		CMZ240.3.10
<p>MODULO MOTORIZZATO ASSIALE BISPORGENTE H=75mm Axial opposite face twin driven tool H=75mm Axial angetriebenes Werkzeug halb vorspringend H=75mm</p>		CMZ240.3.20

		PAGINA Page Seite
<p>MODULO MOTORIZZATO ASSIALE BISPORGENTE H=75mm Axial opposite face twin driven tool H=75mm Axial angetriebenes Werkzeug halb vorspringend H=75mm</p>		CMZ240.3.21
<p>MODULO MOTORIZZATO ASSIALE 2 USCITE IN Y H=55mm Axial single side twin head driven tool in Y H=55mm Axial angetriebenes Werkzeug 2 Ausgaenge in Y H=55mm</p>		CMZ260.3.10
<p>MODULO MOTORIZZATO ASSIALE 2 USCITE IN Y H=75mm Axial single side twin head driven tool in Y H=75mm Axial angetriebenes Werkzeug 2 Ausgaenge in Y H=75mm</p>		CMZ260.3.20
<p>MODULO MOTORIZZATO ORIENTABILE 0-90° 0-90° adjustable angle driven tool Angetriebenes Werkzeug schwenkbar 0-90°</p>		CMZ330.3.00
<p>MODULO MOTORIZZATO ORIENTABILE ±90° ±90° adjustable angle driven tool Angetriebenes Werkzeug schwenkbar ±90°</p>		CMZ333.3.00
<p>MODULO MOTORIZZATO ORIENTABILE ±90° CON NONIO DIGITALE ±90° adjustable angle driven tool with digital display Angetriebenes Werkzeug schwenkbar ±90° mit digital display</p>		CMZ333.3.01
<p>MODULO MOTORIZZATO ORIENTABILE ±90° ±90° adjustable angle driven tool Angetriebenes Werkzeug schwenkbar ±90°</p>		CMZ335.3.00
<p>MODULO MOTORIZZATO ORIENTABILE ±90° CON NONIO DIGITALE ±90° adjustable angle driven tool with digital display Angetriebenes Werkzeug schwenkbar ±90° mit digital display</p>		CMZ335.3.01
<p>MODULO MOTORIZZATO ORIENTABILE ±90° MOLTIPLICATO I=1:2 ±90° adjustable angle driven tool geared-up I=1:2 Angetriebenes Werkzeug schwenkbar ±90° uebersetzt I=1:2</p>		CMZ336.3.00
<p>MOD. MOTORIZZ ORIENTABILE ±90° MOLTIPL I=1:2 CON NONIO DIGITALE ±90° adjustable angle driven tool geared-up I=1:2 with digital display Angetriebenes Werkzeug schwenkbar +/-90° uebersetzt I=1:2 mit digital display</p>		CMZ336.3.01
<p>MODULO MOTORIZZATO PORTACREATORE Driven gear hobber Angetriebenes Zahnradwalzfras-Werkzeug</p>		CMZ340.3.00
<p>MODULO MOTORIZZATO ASSIALE MTSK PER POWER SKIVING H=85mm Axial MTSK driven tool for Power Skiving H=85mm Axial MTSK angetriebenes Werkzeug fuer Power Skiving H=85mm</p>		CMZ350.3.00.K

		PAGINA Page Seite
<p>MODULO MOTORIZZATO STOZZATORE CORSA 50mm H=66mm Slotting driven tool 50mm stroke H=66mm Keilnutenstossmaschine 50mm Hub H=66mm</p>		CMZ360.3.00
<p>MODULO MOTORIZZATO STOZZATORE CORSA 25mm H=66mm Slotting driven tool 25mm stroke H=66mm Keilnutenstossmaschine 25mm Hub H=66mm</p>		CMZ360.3.01
<p>MODULO MOTORIZZATO STOZZATORE CORSA 50mm H=76mm Slotting driven tool 50mm stroke H=76mm Keilnutenstossmaschine 50mm Hub H=76mm</p>		CMZ360.3.10
<p>MODULO MOTORIZZATO STOZZATORE CORSA 25mm H=76mm Slotting driven tool 25mm stroke H=76mm Keilnutenstossmaschine 25mm Hub H=76mm</p>		CMZ360.3.11
<p>PORTAUTENSILE RADIALE SINGOLO QD=20mm / QD=3/4" Radial single static tool QD=20mm / QD=3/4" Radial Single-Werkzeughalter QD=20mm / QD=3/4"</p>		CMZ420.3.00
<p>PORTAUTENSILE RADIALE SINGOLO QD=25mm Radial single static tool QD=25mm Radial Single-Werkzeughalter QD=25mm</p>		CMZ423.3.00
<p>PORTAUTENSILE RADIALE DOPPIO QD=20mm / QD=3/4" Radial double static tool QD=20mm / QD=3/4" Radial Doppel-Werkzeughalter QD=20mm / QD=3/4"</p>		CMZ450.3.00
<p>PORTAUTENSILE RADIALE MULTIPLO QD=20mm / QD=3/4" Radial multiple static tool QD=20mm / QD=3/4" Radial Mehrfach-Werkzeughalter QD=20mm / QD=3/4"</p>		CMZ470.3.00
<p>PORTAUTENSILE PER LAMA Radial blade holder Radial Abstechhalter</p>		CMZ510.3.00
<p>PORTAUTENSILE PER LAMA Radial blade holder Radial Abstechhalter</p>		CMZ520.3.01
<p>PORTAUTENSILE PER LAMA CON LUBRIFICAZIONE INTERNA Radial blade holder with internal coolant Radial Abstechhalter mit Innenkuehlung</p>		CMZ520.3.05
<p>PORTAUTENSILE ASSIALE SINGOLO QD=20mm / QD=3/4" Axial single static tool QD=20mm / QD=3/4" Axial Single-Werkzeughalter QD=20mm / QD=3/4"</p>		CMZ550.3.00

		PAGINA Page Seite
<p>PORTAUTENSILE ASSIALE SINGOLO QD=25mm Axial single static tool QD=25mm Axial Single-Werkzeughalter QD=25mm</p>		CMZ552.3.00
<p>PORTAUTENSILE ASSIALE PER BARENO Ø32mm / Ø1 1/4" H=55mm Axial single boring bar holder Ø32mm / Ø1 1/4" H=55mm Axial Bohrhalter Ø32mm / Ø1 1/4" H=55mm</p>		CMZ650.3.10
<p>PORTAUTENSILE ASSIALE SPECIALE PER BARENO Ø32mm / Ø1 1/4" H=55mm Axial special boring bar holder Ø32mm / Ø1 1/4" H=55mm Axial spezial Bohrhalter Ø32mm / Ø1 1/4" H=55mm</p>		CMZ650.3.20
<p>PORTAUTENSILE ASSIALE PER BARENO Ø40mm / Ø32mm / Ø1 1/4" H=75mm Axial single boring bar holder Ø40mm / Ø32mm / Ø1 1/4" H=75mm Axial Bohrhalter Ø40mm / Ø32mm / Ø1 1/4" H=75mm</p>		CMZ660.3.10
<p>PORTAUTENSILE ASSIALE PER BARENO Ø40mm / Ø32mm / Ø1 1/4" H=75mm Axial single boring bar holder Ø40mm / Ø32mm / Ø1 1/4" H=75mm Axial Bohrhalter Ø40mm / Ø32mm / Ø1 1/4" H=75mm</p>		CMZ660.3.20
<p>PORTAUTENSILE ASSIALE PER BARENO Ø32mm H=80mm Axial single boring bar holder Ø32mm H=80mm Axial Bohrhalter Ø32mm H=80mm</p>		CMZ665.3.10
<p>PORTAUTENSILE ASSIALE PER BARENO Ø25mm / Ø1" H=55 mm Axial single boring bar holder Ø25mm / Ø1" H=55 mm Axial Bohrhalter Ø25mm / Ø1" H=55 mm</p>		NKM670.3.10
<p>PORTAUTENSILE ASSIALE PER BARENO Ø25mm / Ø1" H=75 mm Axial single boring bar holder Ø25mm / Ø1" H=75 mm Axial Bohrhalter Ø25mm / Ø1" H=75 mm</p>		CMZ680.3.10
<p>PORTAUTENSILE ASSIALE ARRETRATO PER BARENO Ø32mm H=75mm Axial single rear set boring bar holder Ø32mm H=75mm Axial Bohrhalter zurueckversetzt Ø32mm H=75mm</p>		CMZ847.3.10
<p>PORTAUTENSILE ASSIALE ARRETRATO PER BARENO Ø25mm H=75mm Axial single rear set boring bar holder Ø25mm H=75mm Axial Bohrhalter zurueckversetzt Ø25mm H=75mm</p>		CMZ848.3.10
<p>PORTAUTENSILE ASSIALE PER BARENO 2 POSIZIONI Ø25mm / Ø1" Axial double boring bar holder Ø25mm / Ø1" Axial Bohrhalter 2 Positionen Ø25mm / Ø1"</p>		CMZ864.3.00
<p>PORTAUTENSILE ASSIALE PER BARENO 3 POSIZIONI Ø25mm / Ø1" Axial 3 position boring bar holder Ø25mm / Ø1" Axial Bohrhalter 3 Positionen Ø25mm / Ø1"</p>		CMZ884.3.00

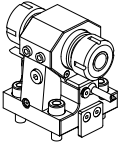
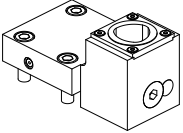
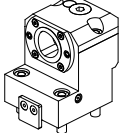
		PAGINA Page Seite
<p>PORTAUTENSILE ASSIALE BISPORGENTE PORTAPINZA H=75mm Axial double collet chuck holder H=75mm Axial Doppel-Spannzangenhalter H=75mm</p>		CMZ940.3.00
<p>PORTAUTENSILE RADIALE SINGOLO ARRETRATO MT CAPTO Single rear-set radial static tool MT CAPTO Radial Single-Werkzeughalter zurueckversetzt MT CAPTO</p>		CMZ430.C.40
<p>PORTAUTENSILE ASSIALE SINGOLO ARRETRATO MT CAPTO Axial rear-set boring single static tool MT CAPTO Axial Single-Werkzeughalter zurueckversetzt MT CAPTO</p>		CMZ555.C.40

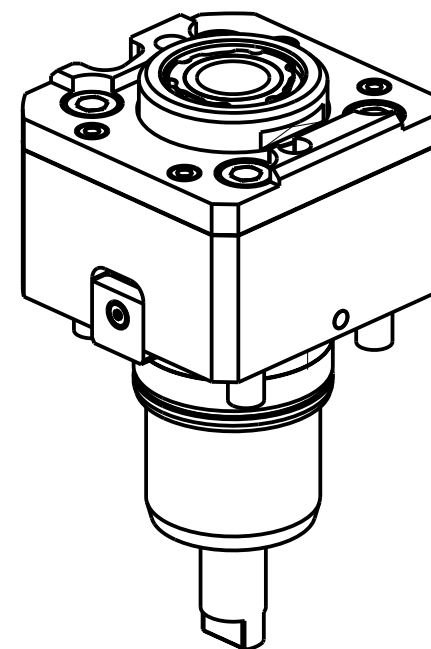
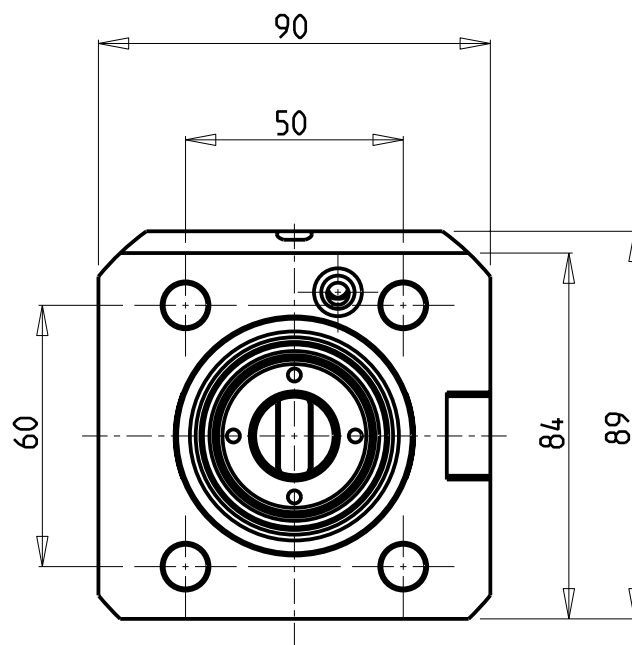
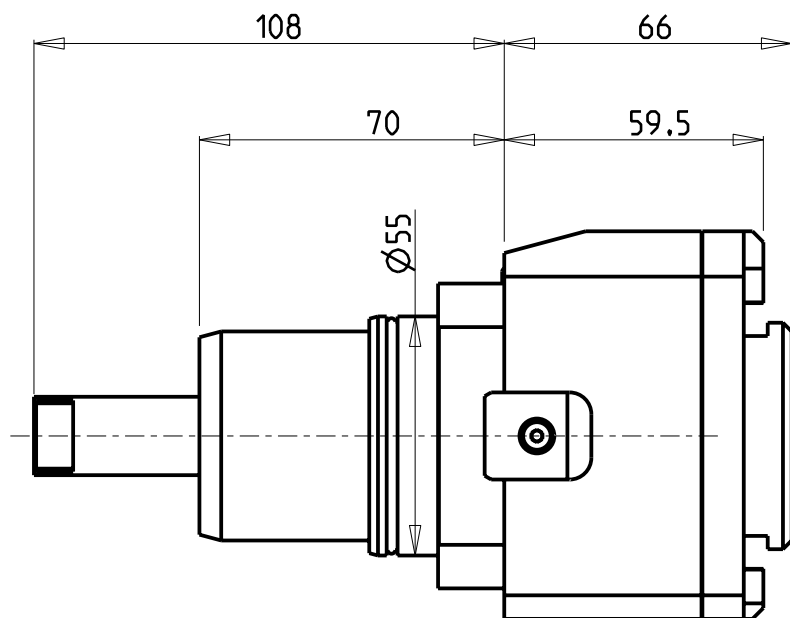

Cod. MT	Mandrino Spindle Spindel	I	RPM	Coppia Max Max Torque Max Drehmoment	Lubrificazione int. Coolant through Innenkuehlung	Lubrificazione est. Ext. coolant Aussenkuehlung	CHIAVI NON INCLUSE Keys not included Schlüssel nicht einbegriffen		
NKM1370132	ERA32	1:1	6000	50Nm	P=70bar	X	CHUB30	CHTAER32ZC *	MNZ0410005 *

- Chiave inclusa
- Key included
- Schlüssel inbegriffen

CMZ
 MOD: TX52 Y3/Y2 QUATTRO/Y2 TW IN - TX66 Y3/Y2 QUATTRO/Y2 TW IN

MODULO MOTORIZZATO RADIALE ALTA PRESSIONE
 Radial driven tool high pressure
 Radial angetriebenes Werkzeug hochdruck

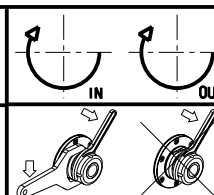

M.T. srl
 Via Casino Albini 480
 Tel. 0541/956034-957884
 Fax 0541/956341
 47842 S. GIOVANNI IN M. (RN)
 e-mail: mtma@mtmarchetti.com
 http://www.mtmarchetti.com

PRODUZIONE MODULI ROTANTI



PAGINA CMZ010-3-20

Subject to change without notice.

10/2018

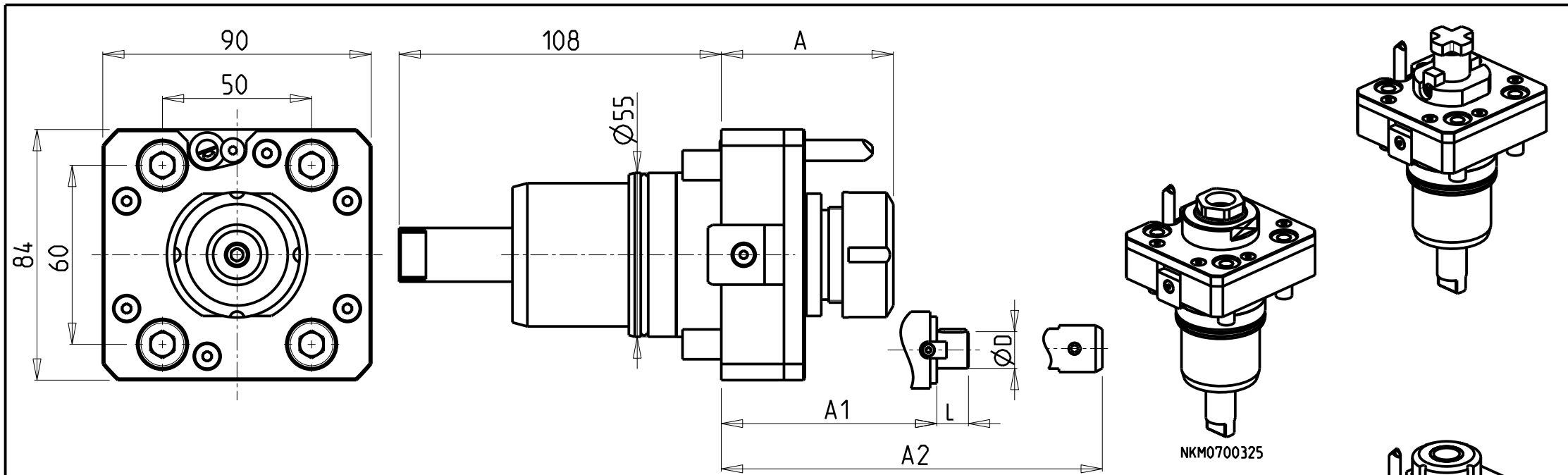

Cod. MT	Mandrino Spindle Spindel	I	RPM	Coppia Max Max Torque Max Drehmoment	Lubrificazione int. Coolant through Innenkuehlung	Lubrificazione est. Ext. coolant Aussenkuehlung	A	A1	A2	D	L	CHIAVI NON INCLUSE Keys not included Schlüssel nicht einbegriffen	
NKM0700325	ERA25	1:1	6000	50Nm	-	X	51	-	-	-	-	CHUB41	CHUB27
NKM0700125	ER25	1:1	6000	50Nm	-	X	57.16	-	-	-	-	CHUB41	CHSTER25
NKM0700225	ER25	1:1	6000	50Nm	P=30bar	X	68.16	-	-	-	-	CHUB41	CHSTER25
NKM0700132	ER32	1:1	6000	50Nm	-	X	61.66	-	-	-	-	CHUB41	CHSTER32
NKM0700232	ER32	1:1	6000	50Nm	P=30bar	X	73.16	-	-	-	-	CHUB41	CHSTER32
NKM0701617	Ø16x17	1:1	6000	50Nm	-	X	-	38	-	16	17	CHUB41	CH_VTCROCE_M08 •
NKM0702219	Ø22x19	1:1	6000	50Nm	-	X	-	39	-	22	19	CHUB41	CH_VTCROCE_M10 •
NKM0702519	Ø1"x19	1:1	6000	50Nm	-	X	-	42	-	1"	21	CHUB41	CH_VTCROCE_M12 •
NKM0700516	WELDON 16	1:1	6000	50Nm	-	X	-	-	48.5	-	-	-	-

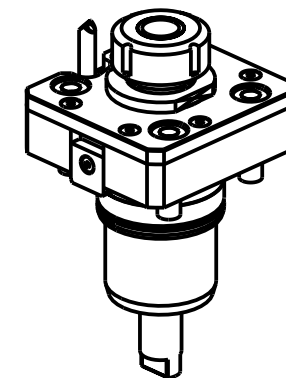

- Chiave inclusa
- Key included
- Schlüssel inbegriffen

CMZ
MOD: TX52 Y3/Y2 QUATTRO/Y2 TW IN - TX66 Y3/Y2 QUATTRO/Y2 TW IN

MODULO MOTORIZZATO RADIALE
Radial driven tool
Radial angetriebenes Werkzeug

Subject to change without notice.

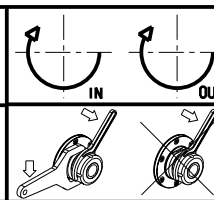

M.T. srl
Via Casino Albini 480
Tel. 0541/956034-957884
Fax 0541/956341
47842 S. GIOVANNI IN M. (RN)
e-mail: mtma@mtmarchetti.com
http://www.mtmarchetti.com

PRODUZIONE MODULI ROTANTI



PAGINA CMZ020-3-00

**CUSCINETTI MAGGIORATI
PER LAVORAZIONI PESANTI**

Reinforced bearings for
heavy machining

Vergroesserte Lager fuer
schwerere Bearbeitungen

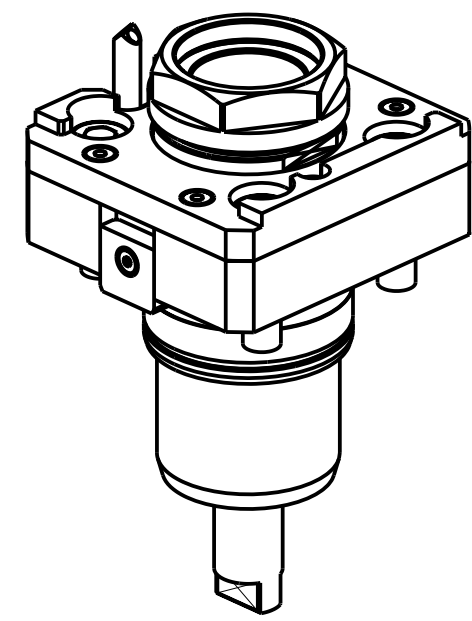
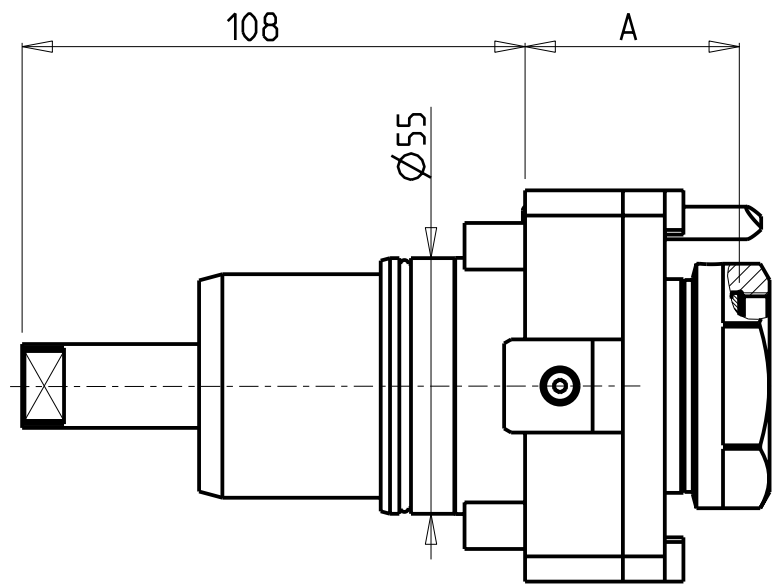
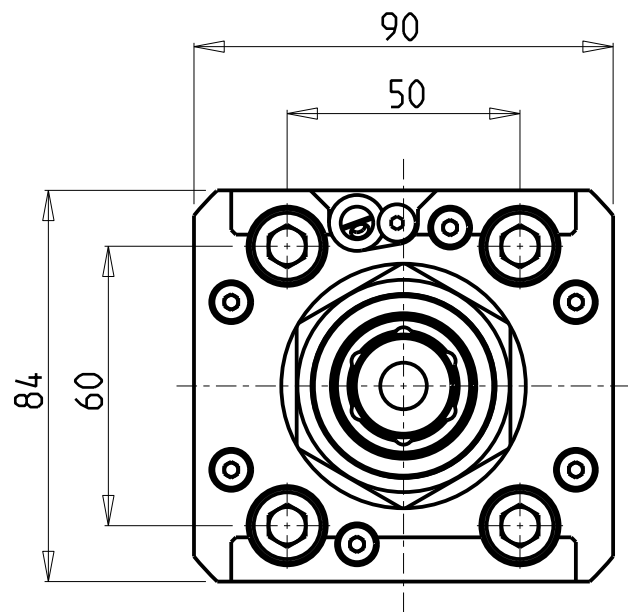

PER PORTAUTENSILI MODULARI MTSK-40 VEDI PAG. TBL300-1-40
FOR MTSK-40 QUIK CHANGE TOOLHOLDERS CLAMPINGS SEE PAGE TBL300-1-40
FUER MTSK-40 MODULARE WERKZEUGAUFNAHMEN SIEHE SEITE TBL300-1-40

Cod. MT	Mandrino Spindle Spindel	I	RPM	Coppia Max Max Torque Max Drehmoment	Lubrificazione int. Coolant through Innenkuehlung	Lubrificazione est. Ext. coolant Aussenkuehlung	A	CHIAVI NON INCLUSE Keys not included Schluessel nicht einbegriffen	
NKM1350140	MTSK-40	1:1	6000	50Nm	-	X	46	CHUB46	OKU0650004 •
NKM1350240	MTSK-40	1:1	6000	50Nm	P=30bar	X	57	CHUB46	OKU0650004 •

- Chiave inclusa
- Key included
- Schluessel inbegriffen

CMZ
MOD: TX52 Y3/Y2 QUATTRO/Y2 TW IN - TX66 Y3/Y2 QUATTRO/Y2 TW IN

MODULO MOTORIZZATO RADIALE MTSK
Radial MTSK driven tool
Radial MTSK angetriebenes Werkzeug

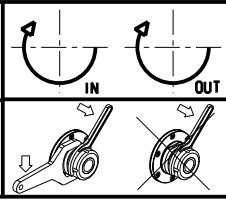

M.T. srl
Via Casino Albini 480
Tel. 0541/956034-957884
Fax 0541/956341
47842 S. GIOVANNI IN M. (RN)
e-mail: mtma@mtmarchetti.com
http://www.mtmarchetti.com

PRODUZIONE MODULI ROTANTI

PAGINA CMZ020-3-00-K

Subject to change without notice.

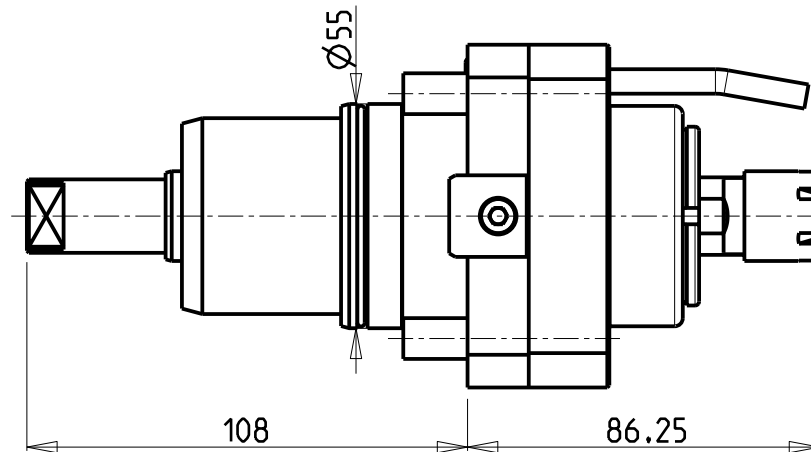
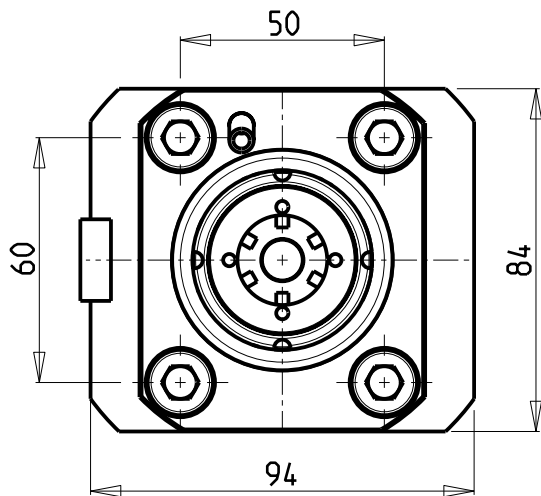

ATTENZIONE - ATTENTION - ACHTUNG

- Per lo smontaggio degli utensili utilizzare sempre la chiave di contrasto come indicato nel manuale d'uso.
- For disassembly of the tools use always the contrast key as mentioned in the user instructions.
- Fuer das Abmontieren der Werkzeuge immer den Gegenschlüssel benutzen wie in der Bedienungsanleitung erwaehnt.

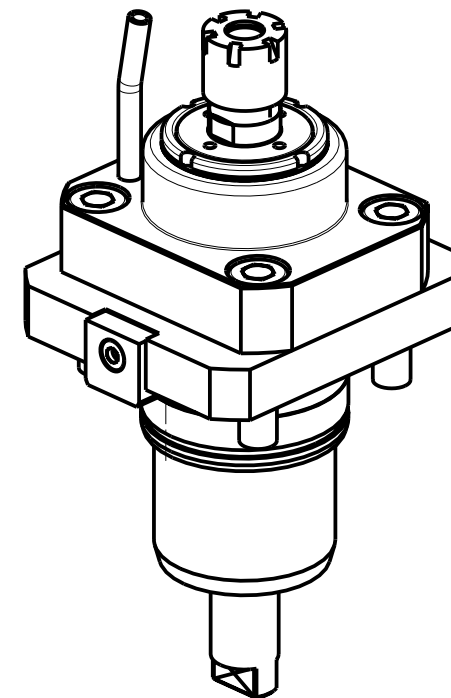

ATTENZIONE - ATTENTION - ACHTUNG

- PRIMA DI UTILIZZARE IL MOTORIZZATO CONSULTARE LE ISTRUZIONI ALLEGATE!
- BEFORE USING THE DRIVEN TOOL, PLEASE CHECK THE ENCLOSED INSTRUCTION SHEET!
- VOR DER BENUTZUNG DES ANGETRIEBENEN WERKZEUGES, DIE BEILIEGENDEN INSTRUKTIONEN DURCHLESEN!

Cod. MT	Mandrino Spindle Spindel	I	RPM	Coppia Max Max Torque Max Drehmoment	Lubrificazione est. Ext. coolant Aussenkuehlung	CHIAVI INCLUDE Keys included Schluessel einbegriffen	
NKM0040016	ER16	1:3	18000	10Nm	X	CHUB17	CHMNER16

CMZ
 MOD: TX52 Y3/Y2 QUATTRO/Y2 TW IN - TX66 Y3/Y2 QUATTRO/Y2 TW IN

MODULO MOTORIZZATO RADIALE Moltiplicato I=1:3
 Radial geared-up I=1:3 driven tool
 Radial angetriebenes Werkzeug uebersetzt I=1:3

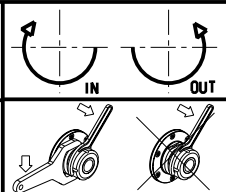

M.T. srl
 Via Casino Albini 480
 Tel. 0541/956034-957884
 Fax 0541/956341
 47842 S. GIOVANNI IN M. (RN)
 e-mail: mtma@mtmarchetti.com..
 http://www.mtmarchetti.com

PRODUZIONE MODULI ROTANTI



PAGINA CMZ055-3-00

Subject to change without notice.

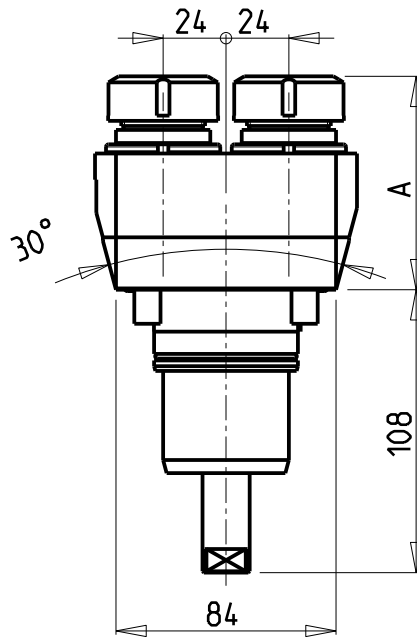
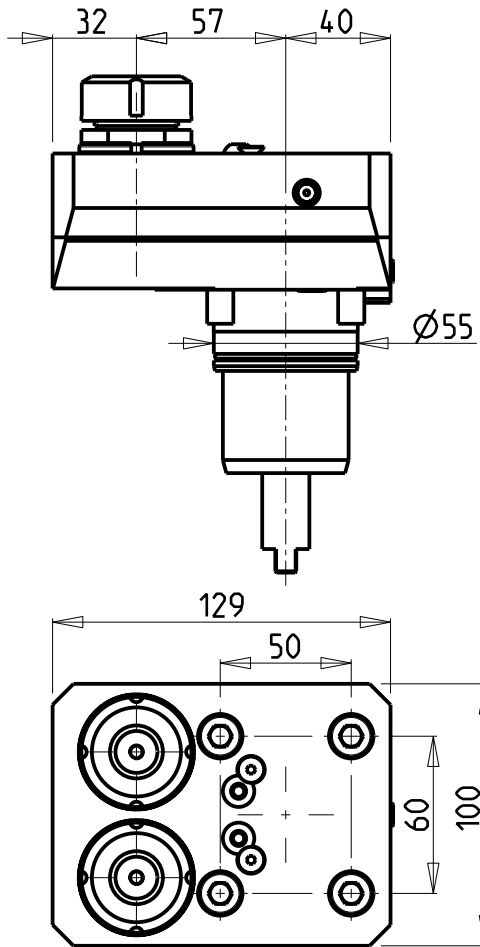

ATTENZIONE - ATTENTION - ACHTUNG

- VERIFICARE LE MISURE DI INGOMBRO PER POSSIBILE INTERFERENZA SU ALCUNI MODELLI DI MACCHINE
- Please check the overall sizes for possible interferences on some machine models
- Bitte überprüfen sie das ausmass um mögliche interferenzen auf einigen maschinen modellen zu vermeiden

ATTENZIONE - ATTENTION - ACHTUNG

- Per lo smontaggio degli utensili utilizzare sempre la chiave di contrasto come indicato nel manuale d'uso.
- For disassembly of the tools use always the contrast key as mentioned in the user instructions.
- Fuer das Abmontieren der Werkzeuge immer den Gegenschlüssel benutzen wie in der Bedienungsanleitung erwaehnt.

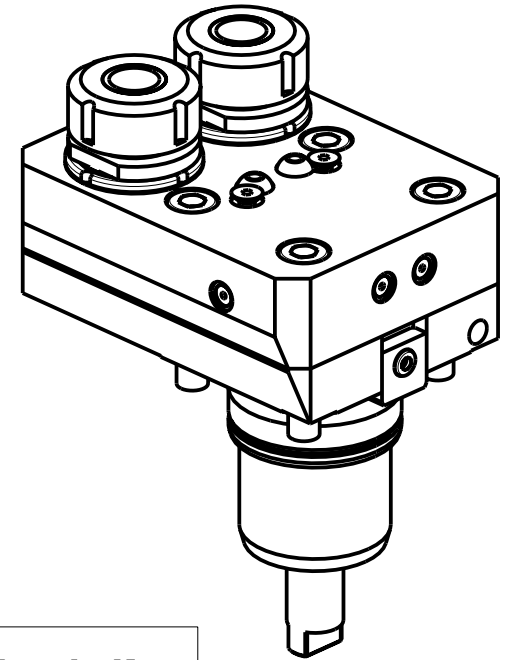

Cod. MT	Mandrino Spindle Spindel	I	RPM	Coppia Max Max Torque Max Drehmoment	Lubrificazione int. Coolant through Innenkuehlung	Lubrificazione est. Ext. coolant Aussenkuehlung	Reversibile lato mandrino/contromandrino Reversible sub/main spindle side Umkehrbare Spindel-seite/Gegenspindel-seite	A	CHIAVI NON INCLUSE Keys not included Schluessel nicht inbegriffen	
NKM0320225	ER25	1:1	6000	30Nm	-	X	X	81.46	CHUB36	CHSTER25
NKM0321225	ER25	1:1	6000	30Nm	P=70bar	X	X	94.46	CHUB36	CHSTER25

NEW

CMZ

MOD: TX52 Y3/Y2 QUATTRO/Y2 TWIN - TX66 Y3/Y2 QUATTRO/Y2 TWIN

MODULO MOTORIZZATO RADIALE 2 USCITE IN Y
Radial single side twin head driven tool in Y
Radial angetriebenes Werkzeug 2 Ausgaenge in Y

Subject to change without notice.

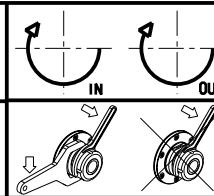

M.T. srl

Via Casino Albini 480
Tel. 0541/956034-957884
Fax 0541/956341
47842 S. GIOVANNI IN M. (RN)
e-mail: mtma@mtmarchetti.com
http://www.mtmarchetti.com

PRODUZIONE MODULI ROTANTI



PAGINA CMZ090-3-00

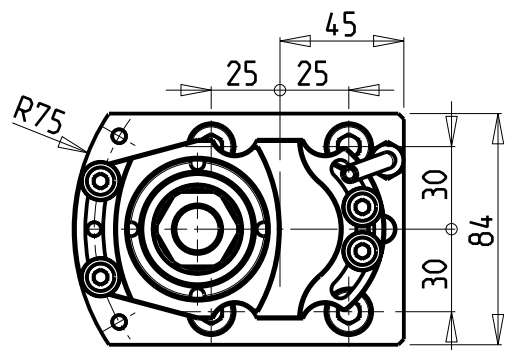
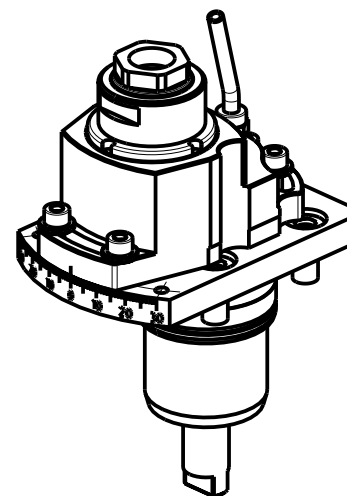
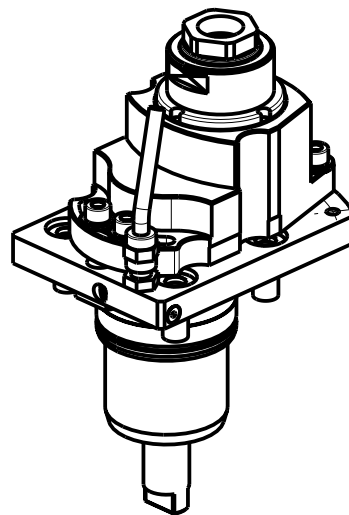
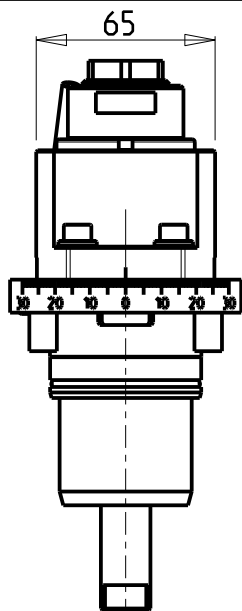
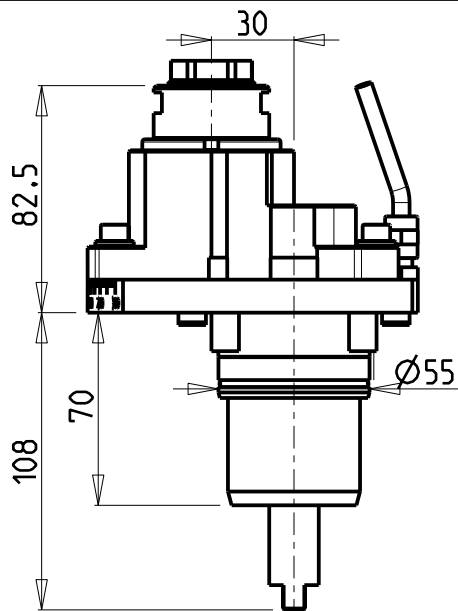

ATTENZIONE - ATTENTION - ACHTUNG

- Per lo smontaggio degli utensili utilizzare sempre la chiave di contrasto come indicato nel manuale d'uso.
- For disassembly of the tools use always the contrast key as mentioned in the user instructions.
- Fuer das Abmontieren der Werkzeuge immer den Gegenschlüssel benutzen wie in der Bedienungsanleitung erwäehnt.

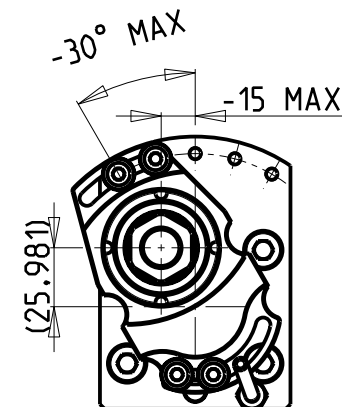
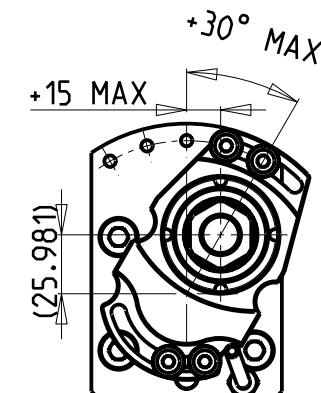

Cod. MT	Mandrino Spindel Spindel	I	RPM	Coppia Max Max Torque Max Drehmoment	Lubrificazione est. Ext. coolant Aussenkuehlung	CHIAVI NON INCLUSE Keys not included Schluessel nicht einbegriffen	
NKM0621025	ERA25	1:1	6000	30Nm	X	CHUB36	CHUB27

CMZ

MOD: TX52 Y3/Y2 QUATTRO/Y2 TW IN - TX66 Y3/Y2 QUATTRO/Y2 TW IN

MODULO MOTORIZZATO RADIALE DISASSATO 30mm ORIENTABILE ±30°

Radial ±30°adjustable angle driven tool re-directed by 30mm

Radial angetriebenes Werkzeug schwenkbar ±30° achsversetzt um 30mm

Subject to change without notice.

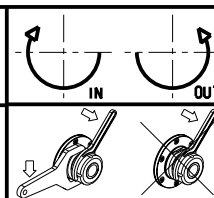

M.T. srl

Via Casino Albini 480
Tel. 0541/956034-957884
Fax 0541/956341
47842 S. GIOVANNI IN M. (RN)
e-mail: mtma@mtmarchetti.com
http://www.mtmarchetti.com

PRODUZIONE MODULI ROTANTI



PAGINA CMZ135-3-00

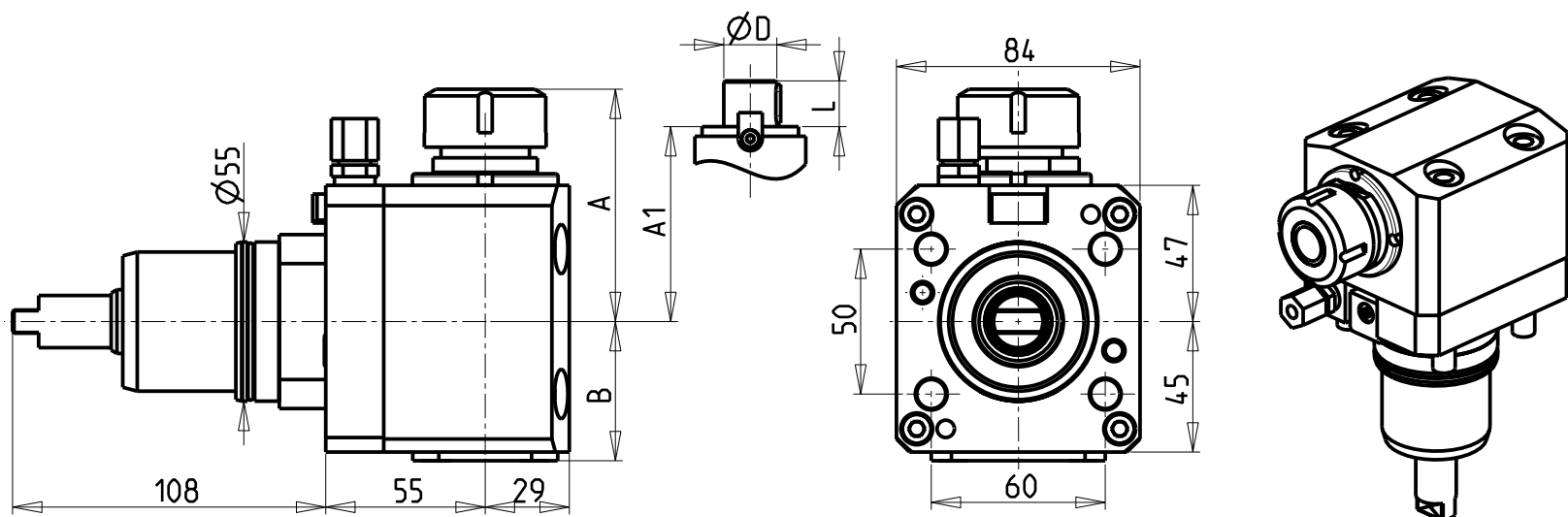

ATTENZIONE - ATTENTION - ACHTUNG

- Per lo smontaggio degli utensili utilizzare sempre la chiave di contrasto come indicato nel manuale d'uso.
- For disassembly of the tools use always the contrast key as mentioned in the user instructions.
- Fuer das Abmontieren der Werkzeuge immer den Gegenschlüssel benutzen wie in der Bedienungsanleitung erwaeht.

- Chiave inclusa
- Key included
- Schluessel inbegriffen

Cod. MT	Mandrino Spindle Spindel	I	RPM	Coppia Max Max Torque Max Drehmoment	Reversibile lato mandrino/controlmandrino Reversible sub/main spindle side Umkehrbare Spindelseite/Gegenspindelseite	Lubr. interna Coolant through Innenkuehlung	Lubr. esterna Ext. coolant Aussenkuehlung	A	A1	B	D	L	CHIAVI NON INCLUDE Keys not included Schluessel nicht einbegriffen	
NKM0021620	ER20	1:1	6000	50Nm	X		X	80.16	-	48	-	-	CHUB36	CHSTER20
NKM0021820	ER20	1:1	6000	50Nm	X	P=70bar	X	80.16	-	58	-	-	CHUB36	CHSTER20
NKM0021420	ER A 20	1:1	6000	50Nm	X		X	69.23	-	48	-	-	CHUB36	CHUB22
NKM0021425	ER25	1:1	6000	50Nm	X		X	80.16	-	48	-	-	CHUB36	CHSTER25
NKM0021625	ER25	1:1	6000	50Nm	X	P=70bar	X	80.16	-	59	-	-	CHUB36	CHSTER25
NKM0022432	ER32	1:1	6000	50Nm	X		X	92.16	-	48	-	-	CHUB36	CHSTER32
NKM0022532	ER32	1:1	6000	50Nm	X	P=70bar	X	92.16	-	57.5	-	-	CHUB36	CHSTER32
NKM0021617	Ø16x17	1:1	6000	50Nm	X		X	-	63	48	16	17	CHUB36	CH_VTCROCE_M08 ▪
NKM0022219	Ø22x19	1:1	6000	50Nm	X		X	-	63	48	22	19	CHUB36	CH_VTCROCE_M10 ▪
NKM0022721	Ø27x21	1:1	6000	50Nm	X		X	-	65.5	48	27	21	CHUB36	CH_VTCROCE_M12 ▪
NKM0022737	Ø27x37	1:1	6000	50Nm	X		X	-	65.5	48	27	37	CHUB36	CH_VTCROCE_M12 ▪

CMZ

MOD: TX52 Y3/Y2 QUATTRO/Y2 TW IN - TX66 Y3/Y2 QUATTRO/Y2 TW IN

MODULO MOTORIZZATO ASSIALE H=55mm

Axial driven tool H=55mm

Axial angetriebenes Werkzeug H=55mm

Subject to change without notice.

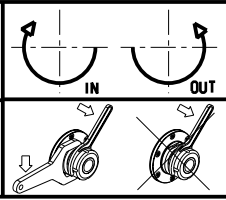

M.T. srl
 Via Casino Albini 480
 Tel. 0541/956034-957884
 Fax 0541/956341
 47842 S. GIOVANNI IN M. (RN)
 e-mail: mtma@tmarchetti.com
 http://www.tmmarchetti.com

PRODUZIONE MODULI ROTANTI



PAGINA CMZ150-3-10

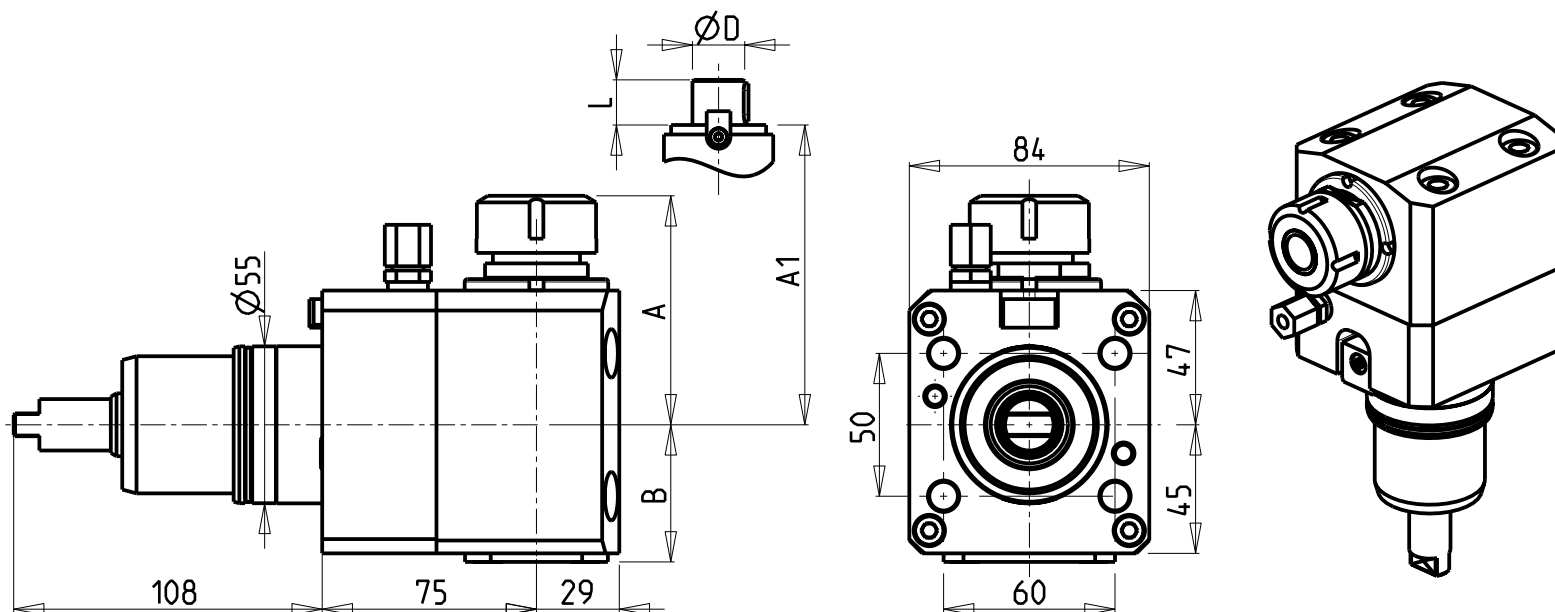

ATTENZIONE - ATTENTION - ACHTUNG

- Per lo smontaggio degli utensili utilizzare sempre la chiave di contrasto come indicato nel manuale d'uso.
- For disassembly of the tools use always the contrast key as mentioned in the user instructions.
- Fuer das Abmontieren der Werkzeuge immer den Gegenschlüssel benutzen wie in der Bedienungsanleitung erwaeht.

ATTENZIONE - ATTENTION - ACHTUNG

- VERIFICARE LE MISURE DI INGOMBRO PER POSSIBILE INTERFERENZA SU ALCUNI MODELLI DI MACCHINE
- Please check the overall sizes for possible interferences on some machine models
- Bitte überprüfen sie das ausmass um mögliche interferenzen auf einigen maschinen modellen zu vermeiden

Cod. MT	Mandrino Spindle Spindel	I	RPM	Coppia Max Max Torque Max Drehmoment	Reversibile lato mandrino/contromandrino Reversible sub/main spindle side Umkehrbare Spindel-seite/Gegenspindel-seite	Lubr.interna Coolant through Innenkuehlung	Lubr. esterna Ext. coolant Aussenkuehlung	A	A1	B	D	L	CHIAVI NON INCLUSE Keys not included Schluessel nicht einbegriffen		• Chiave inclusa • Key included • Schluessel inbegriffen
NKM0061620	ER20	1:1	6000	50Nm	X		X	80.16	-	48	-	-	CHUB36	CHSTER20	
NKM0061820	ER20	1:1	6000	50Nm	X	P=70bar	X	80.16	-	57.5	-	-	CHUB36	CHSTER20	
NKM0061420	ER A 20	1:1	6000	50Nm	X		X	69.23	-	48	-	-	CHUB36	CHUB22	
NKM0061425	ER25	1:1	6000	50Nm	X		X	80.16	-	48	-	-	CHUB36	CHSTER25	
NKM0061625	ER25	1:1	6000	50Nm	X	P=70bar	X	80.16	-	59	-	-	CHUB36	CHSTER25	
NKM0062432	ER32	1:1	6000	50Nm	X		X	92.16	-	48	-	-	CHUB36	CHSTER32	
NKM0062532	ER32	1:1	6000	50Nm	X	P=70bar	X	92.16	-	57.5	-	-	CHUB36	CHSTER32	
NKM0061617	Ø16x17	1:1	6000	50Nm	X		X	-	63	48	16	17	CHUB36	CH_VTCROCE_M08	•
NKM0062219	Ø22x19	1:1	6000	50Nm	X		X	-	63	48	22	19	CHUB36	CH_VTCROCE_M10	•
NKM0062721	Ø27x21	1:1	6000	50Nm	X		X	-	65.5	48	27	21	CHUB36	CH_VTCROCE_M12	•

CMZ

MOD: TX52 Y3/Y2 QUATTRO/Y2 TWIN - TX66 Y3/Y2 QUATTRO/Y2 TWIN

MODULO MOTORIZZATO ASSIALE H=75mm

Axial driven tool H=75mm

Axial angetriebenes Werkzeug H=75mm

Subject to change without notice.

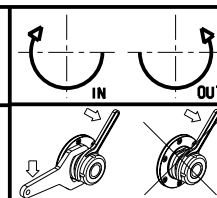

M.T. srl

Via Casino Albini 480
Tel. 0541/956034-957884
Fax 0541/956341
47842 S. GIOVANNI IN M. (RN)
e-mail: mtma@mtmarchetti.com
http://www.mtmarchetti.com

PRODUZIONE MODULI ROTANTI



PAGINA CMZ150-3-20

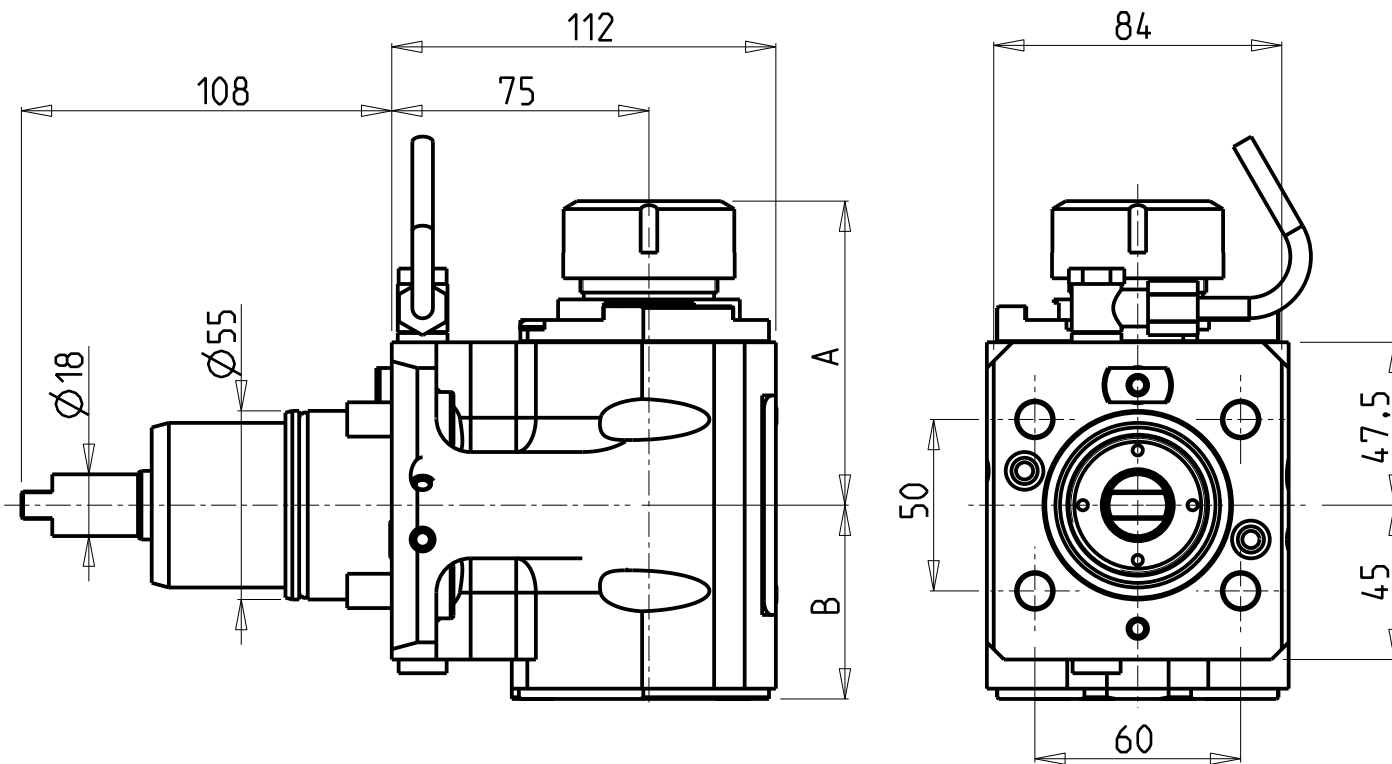

ATTENZIONE - ATTENTION - ACHTUNG

- VERIFICARE LE MISURE DI INGOMBRO PER POSSIBILE INTERFERENZA SU ALCUNI MODELLI DI MACCHINE
- Please check the overall sizes for possible interferences on some machine models
- Bitte überprüfen sie das ausmass um mögliche interferenzen auf einigen maschinen modellen zu vermeiden

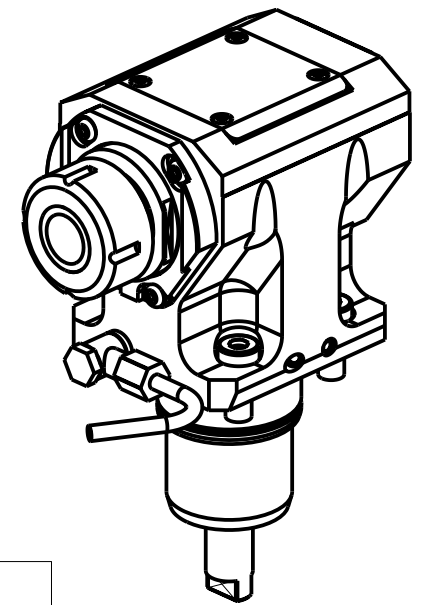

Cod. MT	Mandrino Spindle Spindel	I	RPM	Coppia Max Max Torque Max Drehmoment	Reversibile lato mandrino/contromandrino Reversible sub/main spindle side Umkehrbare Spindel-seite/ Gegenspindel-seite	Lubr.interna Coolant through Innenkuehlung	Lubr. esterna Ext. coolant Aussenkuehlung	A	B	CHIAVI NON INCLUSE Keys not included Schlüssel nicht einbegriffen	
NKM1390132	ER32	1:1	6000	50Nm	X	-	X	88.7	56.5	CHSTER32	OKU0650004 ▪
NKM1390140	ER40	1:1	6000	50Nm	X	-	X	99.2	56.5	CHSTER40	OKU0650004 ▪
NKM1390232	ER32	1:1	6000	50Nm	X	P=70bar	X	88.7	67.5	CHSTER32	OKU0650004 ▪
NKM1390240	ER40	1:1	6000	50Nm	X	P=70bar	X	99.2	67.5	CHSTER40	OKU0650004 ▪

- Chiave inclusa
- Key included
- Schlüssel inbegriffen

CMZ
 MOD: TX52 Y3/Y2 QUATTRO/Y2 TW IN - TX66 Y3/Y2 QUATTRO/Y2 TW IN

MODULO MOTORIZZATO ASSIALE H=75mm
 Axial driven tool H=75mm
 Axial angetriebenes Werkzeug H=75mm

Subject to change without notice.

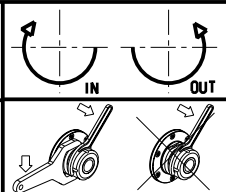

M.T. srl
 Via Casino Albini 480
 Tel. 0541/956034-957884
 Fax 0541/956341
 47842 S. GIOVANNI IN M. (RN)
 e-mail: mtma@mtmarchetti.com
 http://www.mtmarchetti.com

PRODUZIONE MODULI ROTANTI



PAGINA CMZ150-3-21

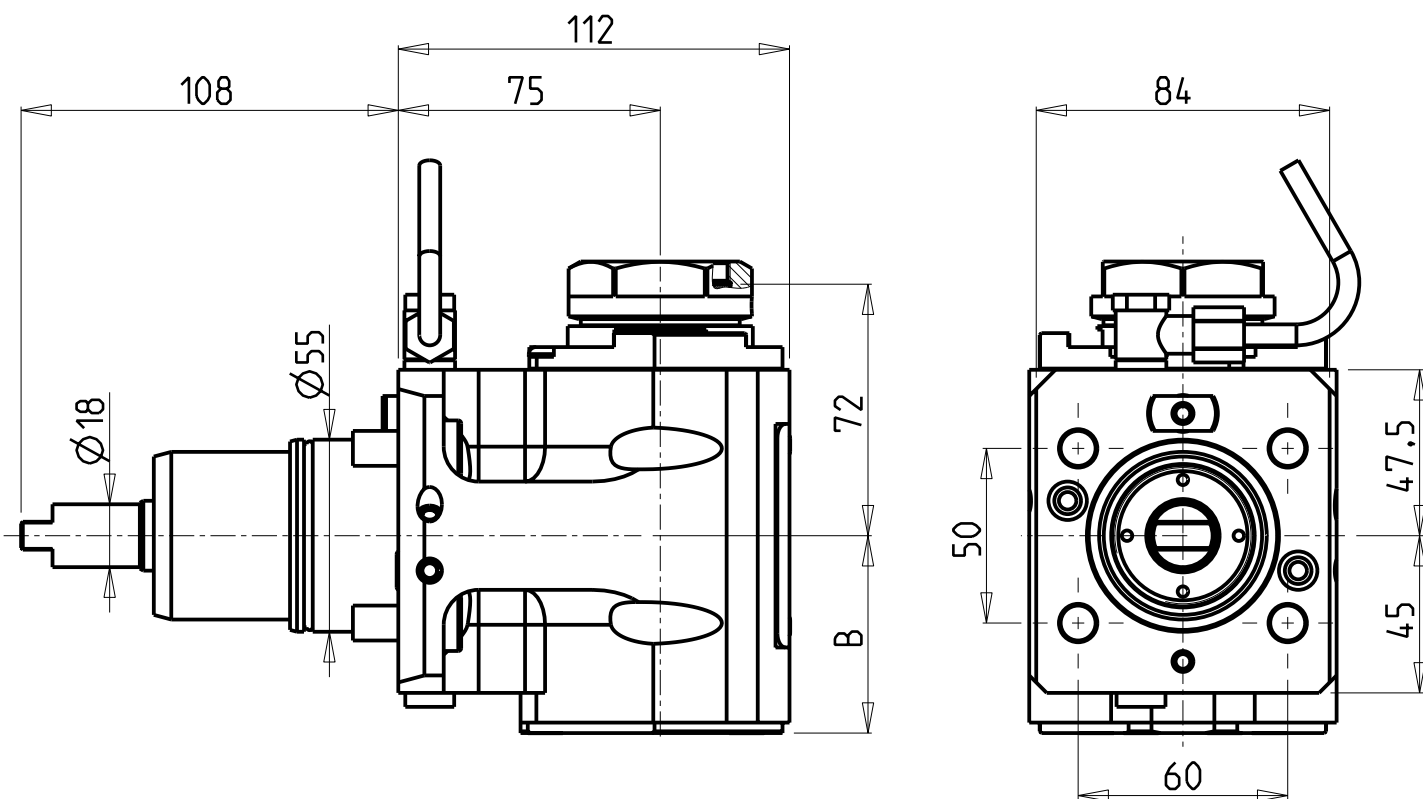

ATTENZIONE - ATTENTION - ACHTUNG

- VERIFICARE LE MISURE DI INGOMBRO PER POSSIBILE INTERFERENZA SU ALCUNI MODELLI DI MACCHINE
- Please check the overall sizes for possible interferences on some machine models
- Bitte überprüfen sie das ausmass um mögliche interferenzen auf einigen maschinen modellen zu vermeiden

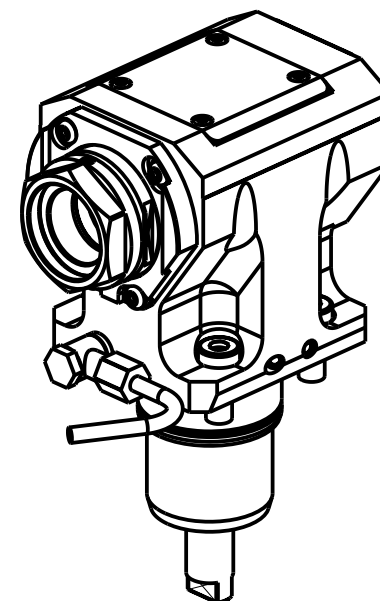

PER PORTAUTENSILI MODULARI MTSK-40 VEDI PAG. TBL300-1-40
 FOR MTSK-40 QUICK CHANGE TOOLHOLDERS CLAMPINGS SEE PAGE TBL300-1-40
 FUER MTSK-40 MODULARE WERKZEUGAUFNAHMEN SIEHE SEITE TBL300-1-40

Cod. MT	Mandrino Spindel Spindel	I	RPM	Coppia Max Max Torque Max Drehmoment	Reversibile lato mandrino/contromandrino Reversible sub/main spindle side Umkehrbare Spindel-seite/ Gegenspindel-seite	Lubrificazione int. Coolant through Innenkuehlung	Lubrificazione est. Ext. coolant Aussenkuehlung	B	CHIAVI NON INCLUDE Keys not included Schluessel nicht einbegriffen	
NKM1410140	MTSK-40	1:1	6000	50Nm	X	-	X	56.5	CHUB46	OKU0650004 *
NKM1410240	MTSK-40	1:1	6000	50Nm	X	P=70bar	X	67.5	CHUB46	OKU0650004 *

- Chiave inclusa
- Key included
- Schluessel inbegriffen

CMZ
 MOD: TX52 Y3/Y2 QUATTRO/Y2 TW IN - TX66 Y3/Y2 QUATTRO/Y2 TW IN

MODULO MOTORIZZATO ASSIALE MTSK H=75mm
 Axial MTSK driven tool H=75mm
 Axial MTSK angetriebenes Werkzeug H=75mm

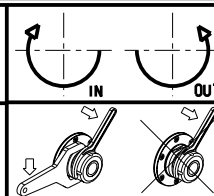

M.T. srl
 Via Casino Albini 480
 Tel. 0541/956034-957884
 Fax 0541/956341
 47842 S. GIOVANNI IN M. (RN)
 e-mail: mtma@mtmarchetti.com
 http://www.mtmarchetti.com

PRODUZIONE MODULI ROTANTI



PAGINA CMZ150-3-21-K

Subject to change without notice.

10/2018

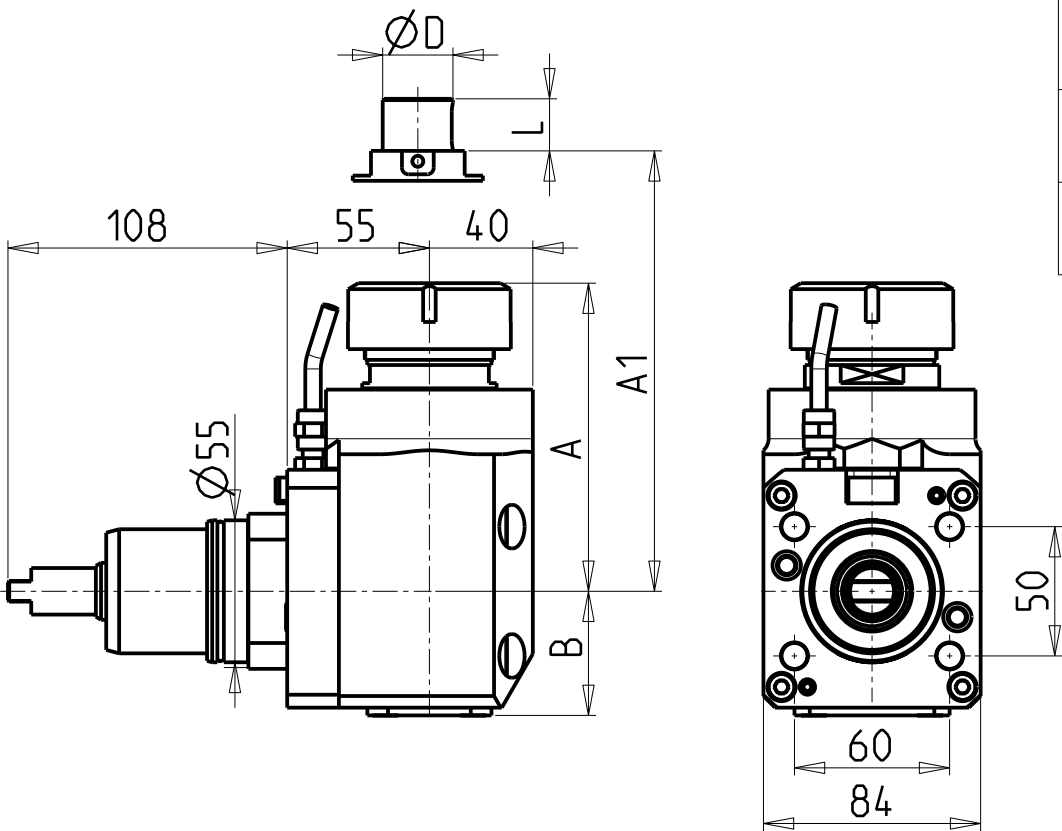

CUSCINETTI MAGGIORATI PER LAVORAZIONI PESANTI

Reinforced bearings for
heavy machining

Vergroesserte Lager fuer
schwerere Bearbeitungen

ATTENZIONE - ATTENTION - ACHTUNG

- Per lo smontaggio degli utensili utilizzare sempre la chiave di contrasto come indicato nel manuale d'uso.
- For disassembly of the tools use always the contrast key as mentioned in the user instructions.
- Fuer das Abmontieren der Werkzeuge immer den Gegenschlüssel benutzen wie in der Bedienungsanleitung erwaeht.

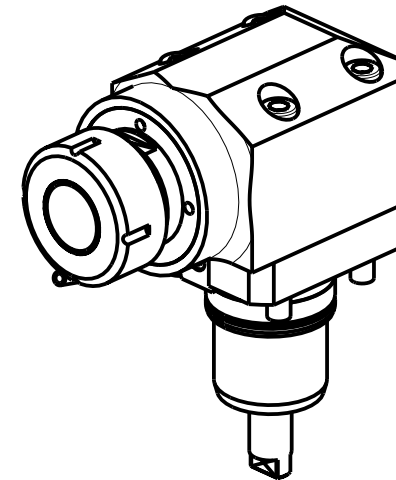

- Chiave inclusa
- Key included
- Schluessel inbegriffen

Cod. MT	Mandrino Spindle Spindel	I	RPM	Coppia Max Max Torque Max Drehmoment	Reversibile lato mandrino/contromandrino Reversible sub/main spindle side Umkehrbare Spindelsete/Gegenspindelsete	Lubr.interna Coolant through Innenkuehlung	Lubrificazione est. Ext. coolant Ausseinkuehlung	A	B	A1	ØD	L	CHIAVI NON INCLUDE Keys not included Schluessel nicht einbegriffen	
NKM0070140	ER40	1:1	6000	50Nm	X	-	X	119.16	48	-	-	-	CHUB46	CHSTER40
NKM0070240	ER40	1:1	6000	50Nm	X	P=70bar	X	119.16	58	-	-	-	CHUB46	CHSTER40
NKM0072519	Ø1"x19	1:1	6000	50Nm	X	-	X	-	48	91.5	1"	19	CHUB46	CH_VTCROCE_M12
NKM0072721	Ø27x21	1:1	6000	50Nm	X	-	X	-	48	91.5	27	20	CHUB36	CH_VTCROCE_M12

CMZ

MOD: TX52 Y3/Y2 QUATTRO/Y2 TW IN - TX66 Y3/Y2 QUATTRO/Y2 TW IN

MODULO MOTORIZZATO ASSIALE MAGGIORATO H=55mm

Axial reinforced driven tool H=55mm

Axial angetriebenes Werkzeug vergroessert H=55mm

Subject to change without notice.

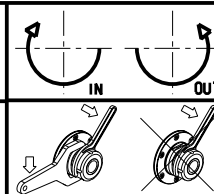

M.T. srl

Via Casio Albini 480
Tel. 0541/956034-957884
Fax 0541/956341
47842 S. GIOVANNI IN M. (RN)
e-mail: mtma@mtmarchetti.com
http://www.mtmarchetti.com

PRODUZIONE MODULI ROTANTI



PAGINA CMZ170-3-10

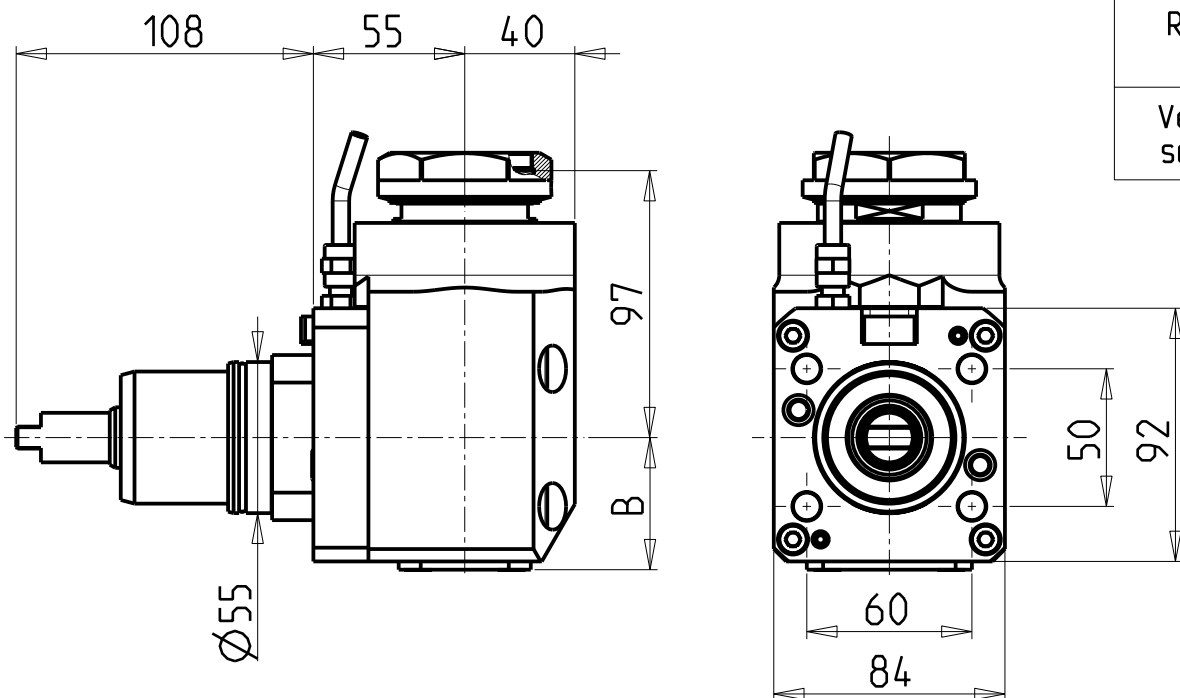

CUSCINETTI MAGGIORATI PER LAVORAZIONI PESANTI

Reinforced bearings for
heavy machining

Vergroesserte Lager fuer
schwerere Bearbeitungen

ATTENZIONE - ATTENTION - ACHTUNG

- Per lo smontaggio degli utensili utilizzare sempre la chiave di contrasto come indicato nel manuale d'uso.
- For disassembly of the tools use always the contrast key as mentioned in the user instructions.
- Fuer das Abmontieren der Werkzeuge immer den Gegenschlüssel benutzen wie in der Bedienungsanleitung erwaeht.

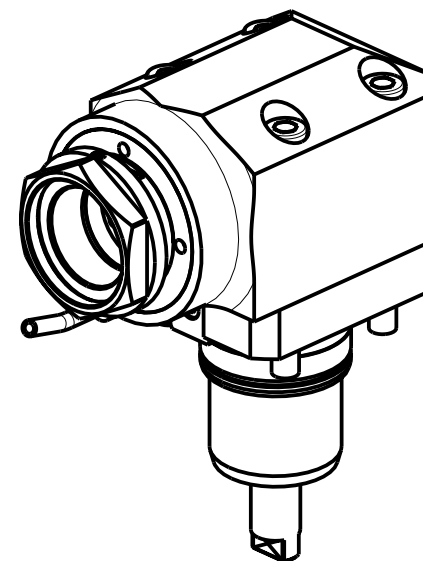

PER PORTAUTENSILI MODULARI MTSK-50 VEDI PAG. TBL300-1-50
FOR MTSK-50 QUICK CHANGE TOOLHOLDERS CLAMPINGS SEE PAGE TBL300-1-50
FUER MTSK-50 MODULARE WERKZEUGAUFNAHMEN SIEHE SEITE TBL300-1-50

Cod. MT	Mandrino Spindle Spindel	I	RPM	Coppia Max Max Torque Max Drehmoment	Reversibile lato mandrino/contromandrino Reversible sub/main spindle side Umkehrbare Spindel-seite/ Gegenspindel-seite	Lubr.interna Coolant through Innenkuehlung	Lubrificazione est. Ext. coolant Aussenkuehlung	B	CHIAVI NON INCLUSE Keys not included Schlüssel nicht einbegriffen	
NKM1000150	MTSK-50	1:1	6000	50Nm	X	-	X	48	CHUB46	CHUB55
NKM1000250	MTSK-50	1:1	6000	50Nm	X	P=70bar	X	58	CHUB46	CHUB55

CMZ

MOD: TX52 Y3/Y2 QUATTRO/Y2 TW IN - TX66 Y3/Y2 QUATTRO/Y2 TW IN

MODULO MOTORIZZATO ASSIALE MAGGIORATO MTSK H=55mm

Axial MTSK reinforced driven tool H=55mm

Axial MTSK angetriebenes Werkzeug vergroessert H=55mm

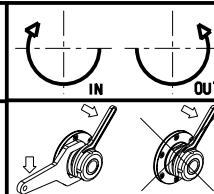

M.T. srl

Via Casino Albini 480
Tel. 0541/956034-957884
Fax 0541/956341

47842 S. GIOVANNI IN M. (RN)
e-mail: mtma@mtmarchetti.com
http://www.mtmarchetti.com

PRODUZIONE MODULI ROTANTI



PAGINA CMZ170-3-10-K

Subject to change without notice.

10/2018

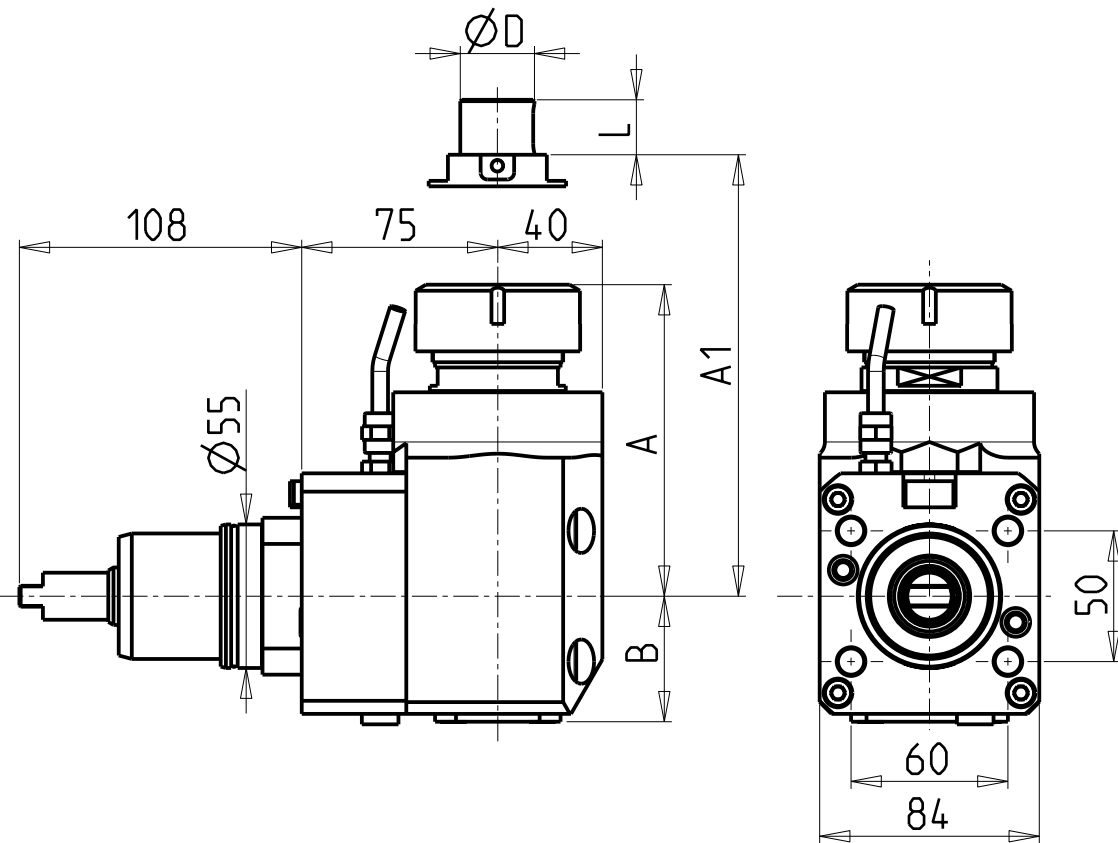

CUSCINETTI MAGGIORATI PER LAVORAZIONI PESANTI

Reinforced bearings for
heavy machining

Vergroesserte Lager fuer
schwerere Bearbeitungen

ATTENZIONE - ATTENTION - ACHTUNG

- Per lo smontaggio degli utensili utilizzare sempre la chiave di contrasto come indicato nel manuale d'uso.
- For disassembly of the tools use always the contrast key as mentioned in the user instructions.
- Fuer das Abmontieren der Werkzeuge immer den Gegenschlüssel benutzen wie in der Bedienungsanleitung erwäehnt.

ATTENZIONE - ATTENTION - ACHTUNG

- VERIFICARE LE MISURE DI INGOMBRO PER POSSIBILE INTERFERENZA SU ALCUNI MODELLI DI MACCHINE
- Please check the overall sizes for possible interferences on some machine models
- Bitte überprüfen sie das ausmass um mögliche interferenzen auf einigen maschinen modellen zu vermeiden

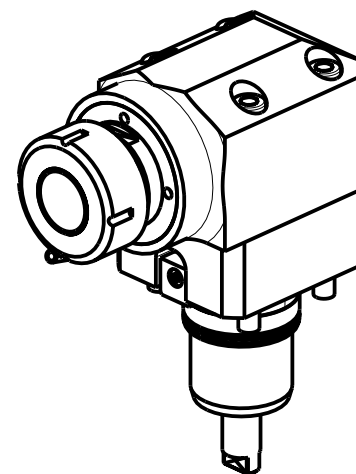

- Chiave inclusa
- Key included
- Schlüssel inbegriffen

Cod. MT	Mandrino Spindle Spindel	I	RPM	Coppia Max Max Torque Max Drehmoment	Reversibile lato mandrino/contromandrino Reversible sub/main spindle side Umkehrbare Spindelsete/Gegenspindelsete	Lubr.interna Coolant through Innenkuehlung	Lubrificazione est. Ext. coolant Aussenkuehlung	A	B	A1	ØD	L	CHIAVI NON INCLUDE Keys not included Schluessel nicht einbegriffen	
NKM0990140	ER40	1:1	6000	50Nm	X	-	X	119.16	48	-	-	-	CHUB46	CHSTER40
NKM0990240	ER40	1:1	6000	50Nm	X	P=70bar	X	119.16	58	-	-	-	CHUB46	CHSTER40
NKM0992519	Ø1"x19	1:1	6000	50Nm	X	-	X	-	48	91.5	1"	19	CHUB46	CH_VTCROCE_M12
NKM0992721	Ø27x21	1:1	6000	50Nm	X	-	X	-	48	91.5	27	20	CHUB36	CH_VTCROCE_M12

CMZ

MOD: TX52 Y3/Y2 QUATTRO/Y2 TW IN - TX66 Y3/Y2 QUATTRO/Y2 TW IN

MODULO MOTORIZZATO ASSIALE MAGGIORATO H=75mm

Axial reinforced driven tool H=75mm

Axial angetriebenes Werkzeug vergroessert H=75mm

Subject to change without notice.

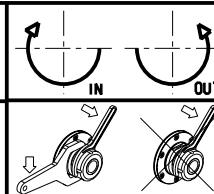

M.T. srl

Via Casino Albini 480
Tel. 0541/956034-957884
Fax 0541/956341

47842 S. GIOVANNI IN M. (RN)
e-mail: mtma@mtmarchetti.com
http://www.mtmarchetti.com

PRODUZIONE MODULI ROTANTI



PAGINA CMZ170-3-20

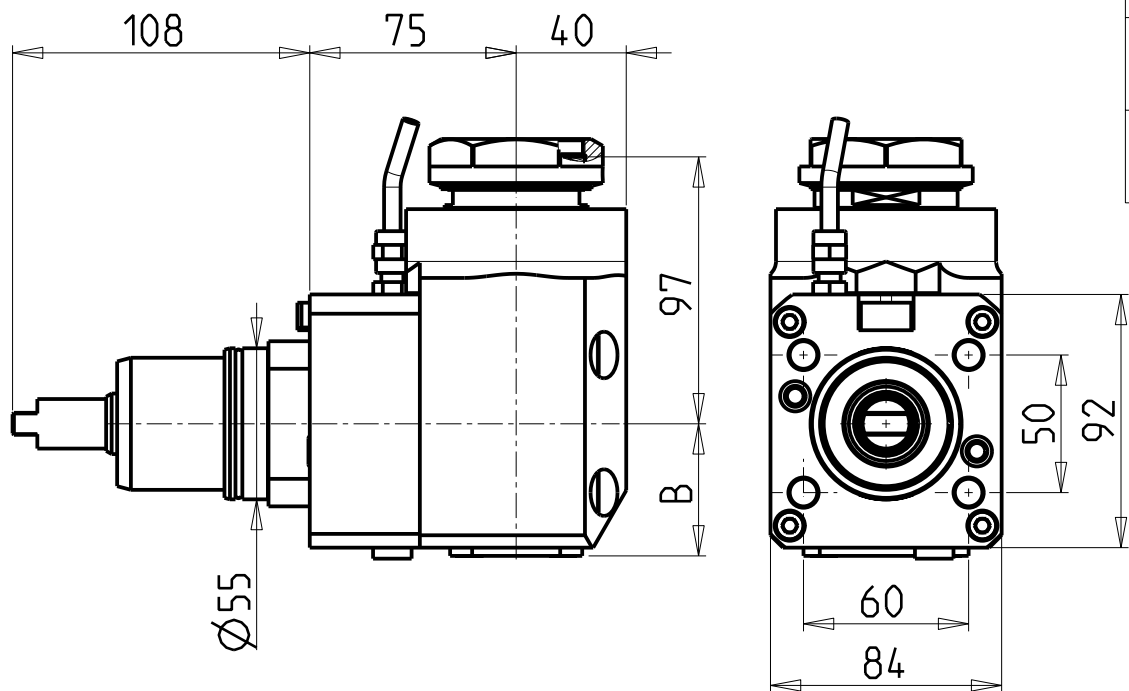

CUSCINETTI MAGGIORATI PER LAVORAZIONI PESANTI

Reinforced bearings for
heavy machining

Vergroesserte Lager fuer
schwerere Bearbeitungen

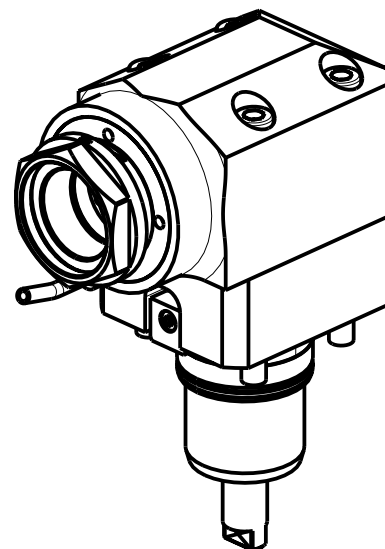

ATTENZIONE - ATTENTION - ACHTUNG

- Per lo smontaggio degli utensili utilizzare sempre la chiave di contrasto come indicato nel manuale d'uso.
- For disassembly of the tools use always the contrast key as mentioned in the user instructions.
- Fuer das Abmontieren der Werkzeuge immer den Gegenschlüssel benutzen wie in der Bedienungsanleitung erwaeht.

ATTENZIONE - ATTENTION - ACHTUNG

- VERIFICARE LE MISURE DI INGOMBRO PER POSSIBILE INTERFERENZA SU ALCUNI MODELLI DI MACCHINE
- Please check the overall sizes for possible interferences on some machine models
- Bitte ueberpruefen sie das ausmass um moegliche interferenzen auf einigen maschinen modellen zu vermeiden

PER PORTAUTENSILI MODULARI MTSK-50 VEDI PAG. TBL300-1-50
FOR MTSK-50 QUIK CHANGE TOOLHOLDERS CLAMPINGS SEE PAGE TBL300-1-50
FUER MTSK-50 MODULARE WERKZEUGAUFNAHMEN SIEHE SEITE TBL300-1-50

Cod. MT	Mandrino Spindle Spindel	I	RPM	Coppia Max Max Torque Max Drehmoment	Reversibile lato mandrino/contromandrino Reversible sub/main spindle side Umkehrbare Spindel-seite/ Gegenspindel-seite	Lubr.interna Coolant through Innenkuehlung	Lubrificazione est. Ext. coolant Aussenkuehlung	B	CHIAVI NON INCLUSE Keys not included Schluesssel nicht einbegriffen	
NKM1010150	MTSK-50	1:1	6000	50Nm	X	-	X	48	CHUB46	CHUB55
NKM1010250	MTSK-50	1:1	6000	50Nm	X	P=70bar	X	58	CHUB46	CHUB55

CMZ

MOD: TX52 Y3/Y2 QUATTRO/Y2 TWIN - TX66 Y3/Y2 QUATTRO/Y2 TWIN

MODULO MOTORIZZATO ASSIALE MAGGIORATO MTSK H=75mm

Axial MTSK reinforced driven tool H=75mm

Axial MTSK angetriebenes Werkzeug vergroessert H=75mm

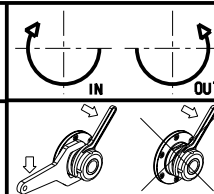

M.T. srl

Via Casino Albini 480
Tel. 0541/956034-957884
Fax 0541/956341

47842 S. GIOVANNI IN M. (RN)
e-mail: mtma@tmarchetti.com
http://www.tmmarchetti.com

PRODUZIONE MODULI ROTANTI



PAGINA CMZ170-3-20-K

Subject to change without notice.

10/2018

ATTENZIONE - ATTENTION - ACHTUNG

- VERIFICARE LE MISURE DI INGOMBRO PER POSSIBILE INTERFERENZA SU ALCUNI MODELLI DI MACCHINE
- Please check the overall sizes for possible interferences on some machine models
- Bitte überprüfen sie das ausmass um mögliche interferenzen auf einigen maschinen modellen zu vermeiden

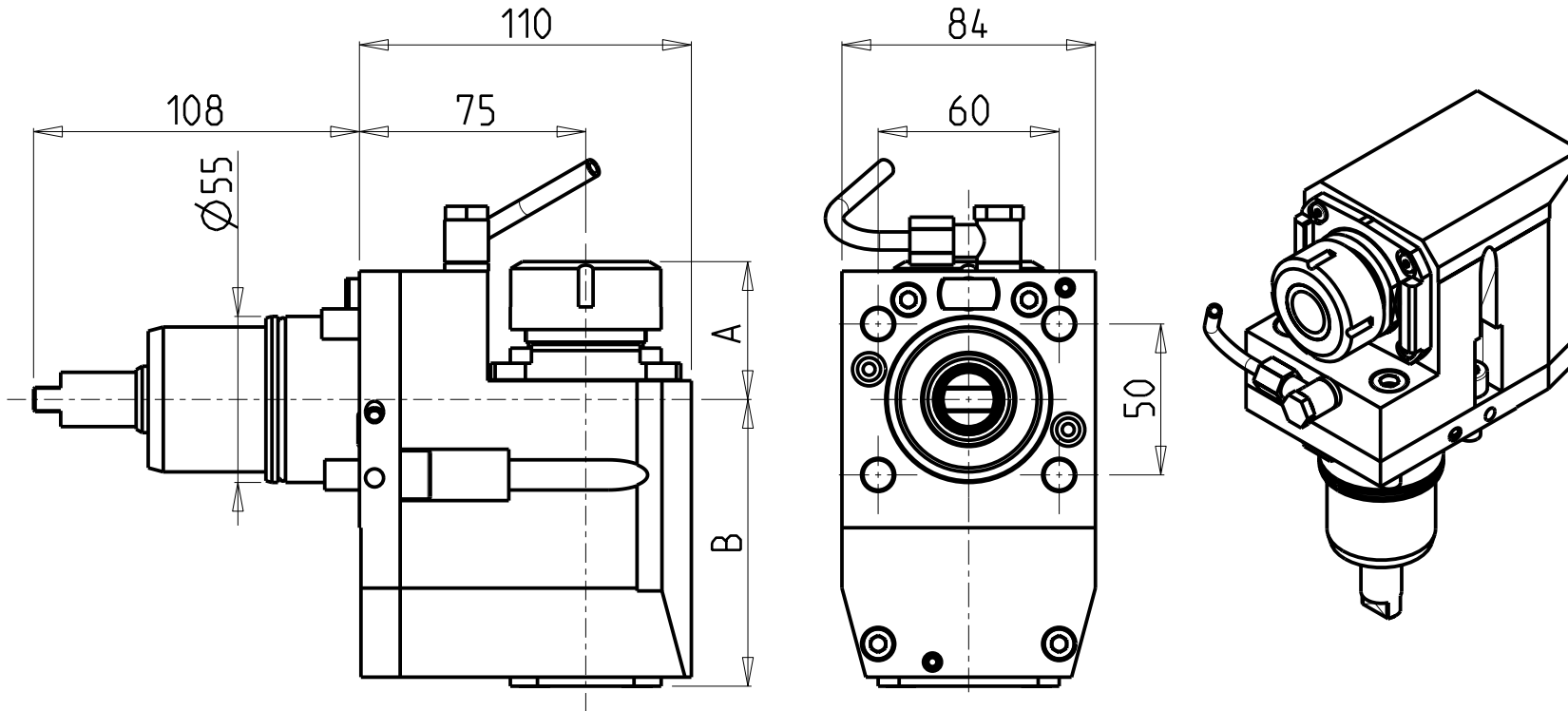

- Chiave inclusa
- Key included
- Schlüssel inbegriffen

Cod. MT	Mandrino Spindle Spindel	I	RPM	Coppia Max Max Torque Max Drehmoment	Reversibile lato mandrino/contromandrino Reversible sub/main spindle side Umkehrbare Spindel-seite/ Gegenspindel-seite	Lubr.interna Coolant through Innenkuehlung	Lubrificazione est. Ext. coolant Aussekuehlung	A	B	CHIAVI NON INCLUSE Keys not included Schlüssel nicht inbegriffen	
NKM1080125	ER25	1:1	6000	50Nm	X	-	X	42.7	95	MNZ0410005	CHSTER25
NKM1080225	ER25	1:1	6000	50Nm	X	P=70bar	X	42.7	108.5	MNZ0410005	CHSTER25
NKM1080132	ER32	1:1	6000	50Nm	X	-	X	45.7	95	MNZ0410005	CHSTER32
NKM1080232	ER32	1:1	6000	50Nm	X	P=70bar	X	45.7	108.5	MNZ0410005	CHSTER32

CMZ
MOD: TX52 Y3/Y2 QUATTRO/Y2 TW IN - TX66 Y3/Y2 QUATTRO/Y2 TW IN

MODULO MOTORIZZATO ASSIALE ARRETRATO H=75mm
Axial rear-set driven tool H=75mm
Axial angetriebenes Werkzeug zurueckversetzt H=75mm

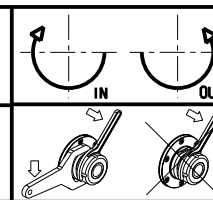

M.T. srl
Via Casino Albini 480
Tel. 0541/956034-957884
Fax 0541/956341
47842 S. GIOVANNI IN M. (RN)
e-mail: mtma@mtmarchetti.com
http://www.mtmarchetti.com

PRODUZIONE MODULI ROTANTI



PAGINA CMZ180-3-10

Subject to change without notice.

10/2018

ATTENZIONE - ATTENTION - ACHTUNG

- VERIFICARE LE MISURE DI INGOMBRO PER POSSIBILE INTERFERENZA SU ALCUNI MODELLI DI MACCHINE
- Please check the overall sizes for possible interferences on some machine models
- Bitte überprüfen sie das ausmass um mögliche interferenzen auf einigen maschinen modellen zu vermeiden

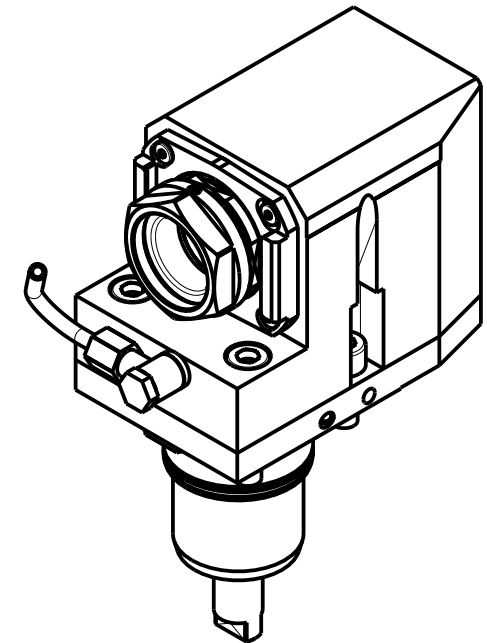
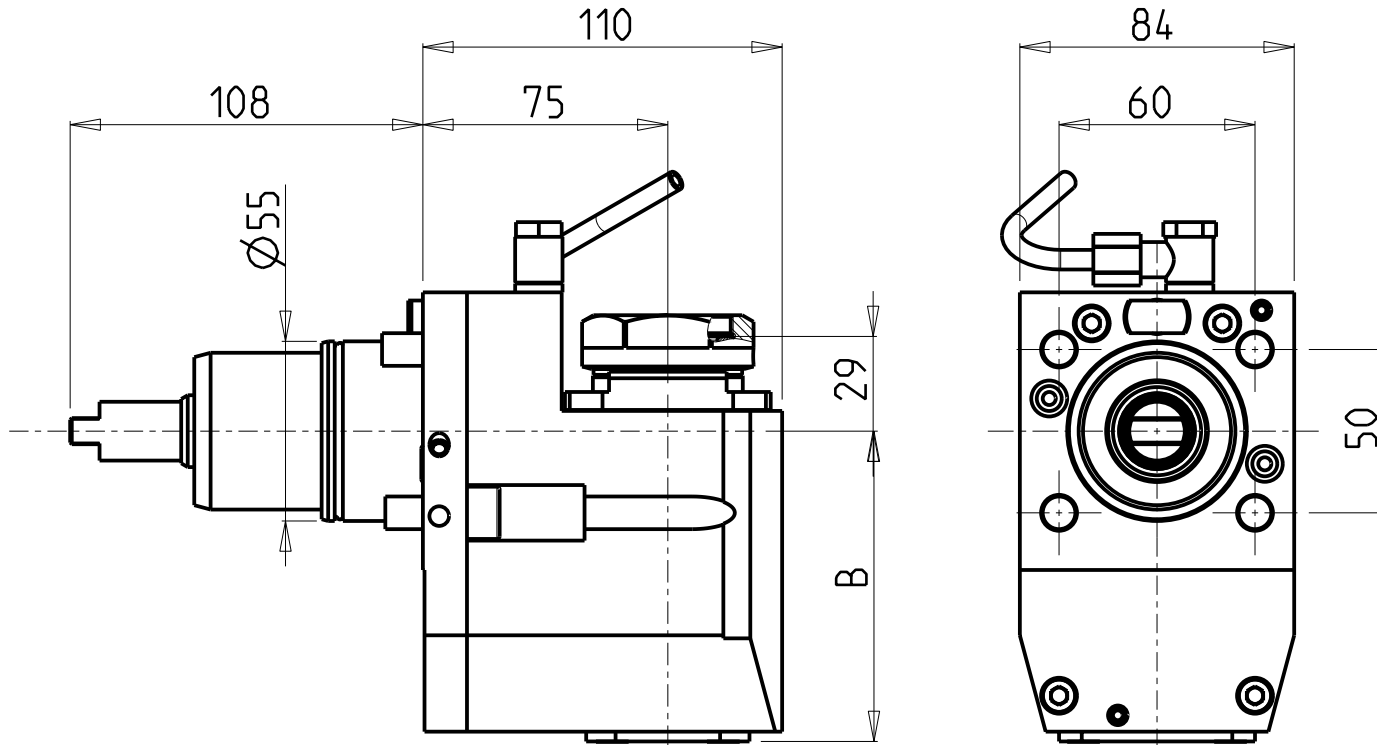

- Chiave inclusa
- Key included
- Schluessel inbegriffen

PER PORTAUTENSILI MODULARI MTSK-40 VEDI PAG. TBL300-1-40
 FOR MTSK-40 QUICK CHANGE TOOLHOLDERS CLAMPINGS SEE PAGE TBL300-1-40
 FUER MTSK-40 MODULARE WERKZEUGAUFNAHMEN SIEHE SEITE TBL300-1-40

Cod. MT	Mandrino Spindle Spindel	I	RPM	Coppia Max Max Torque Max Drehmoment	Reversibile lato mandrino/contromandrino Reversible sub/main spindle side Umkehrbare Spindel-seite/ Gegenspindel-seite	Lubrificazione int. Coolant through Innenkuehlung	Lubrificazione est. Ext. coolant Aussenkuehlung	B	CHIAVI NON INCLUSE Keys not included Schluessel nicht einbegriffen	
NKM1140140	MTSK-40	1:1	6000	50Nm	X	-	X	95	CHUB46	MNZ0410005 ▪
NKM1140240	MTSK-40	1:1	6000	50Nm	X	P=70bar	X	108.5	CHUB46	MNZ0410005 ▪

CMZ
 MOD: TX52 Y3/Y2 QUATTRO/Y2 TW IN - TX66 Y3/Y2 QUATTRO/Y2 TW IN

MODULO MOTORIZZATO RADIALE ARRETRATO MTSK H=75mm
 Radial MTSK rear-set driven tool H=75mm
 Radial MTSK angetriebenes Werkzeug zurueckversetzt H=75mm

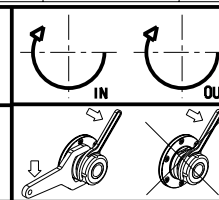

M.T. srl
 Via Casino Albini 480
 Tel. 0541/956034-957884
 Fax 0541/956341
 47842 S. GIOVANNI IN M. (RN)
 e-mail: mtma@mtmarchetti.com
 http://www.mtmarchetti.com

PRODUZIONE MODULI ROTANTI



PAGINA CMZ180-3-10-K

Subject to change without notice.

10/2018

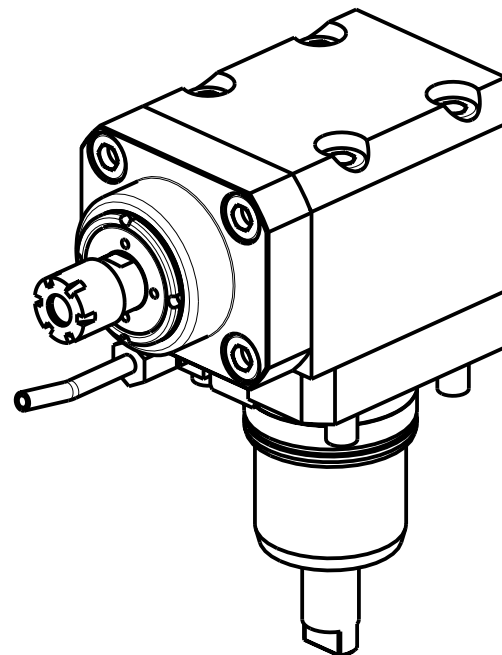
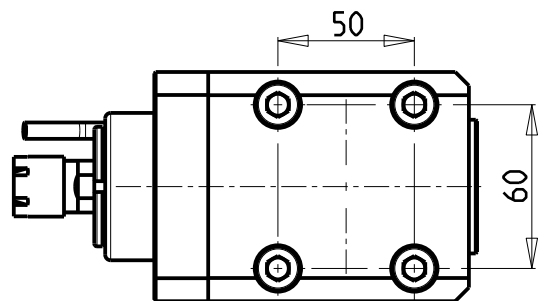
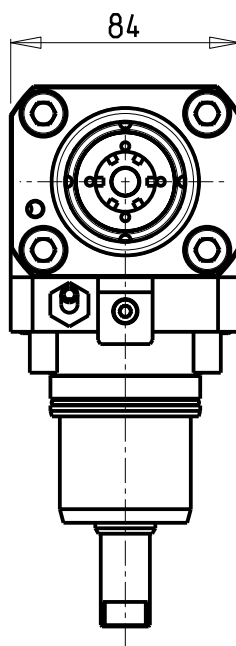
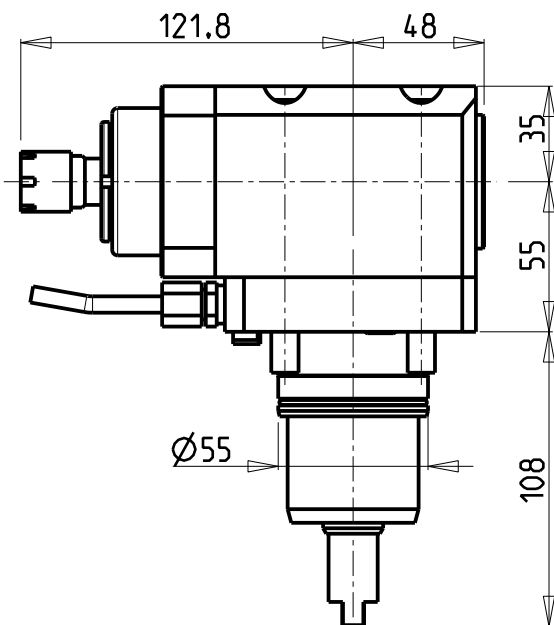

ATTENZIONE - ATTENTION - ACHTUNG

- Per lo smontaggio degli utensili utilizzare sempre la chiave di contrasto come indicato nel manuale d'uso.
- For disassembly of the tools use always the contrast key as mentioned in the user instructions.
- Fuer das Abmontieren der Werkzeuge immer den Gegenschlüssel benutzen wie in der Bedienungsanleitung erwaeht.

ATTENZIONE - ATTENTION - ACHTUNG

- PRIMA DI UTILIZZARE IL MOTORIZZATO CONSULTARE LE ISTRUZIONI ALLEGATE!
- BEFORE USING THE DRIVEN TOOL, PLEASE CHECK THE ENCLOSED INSTRUCTION SHEET!
- VOR DER BENUTZUNG DES ANGETRIEBENEN WERKZEUGES, DIE BEILIEGENDEN INSTRUKTIONEN DURCHLESEN!

Cod. MT	Mandrino Spindle Spindel	I	RPM	Coppia Max Max Torque Max Drehmoment	Reversibile lato mandrino/contromandrino Reversible sub/main spindle side Umkehrbare Spindel-seite/ Gegenspindel-seite	Lubrificazione est. Ext. coolant Aussenkuehlung	CHIAVI INCLUDE Keys included Schlüssel einbegriffen	
							CHUB17	CHMNER16
NKM0050016	ER16	1:3	18000	10Nm	X	X	CHUB17	CHMNER16

CMZ

MOD: TX52 Y3/Y2 QUATTRO/Y2 TW IN - TX66 Y3/Y2 QUATTRO/Y2 TW IN

MODULO MOTORIZZATO ASSIALE MOLTIPLICATO I=1:3 H=55mm

Axial geared-up I=1:3 driven tool H=55mm

Axial angetriebenes Werkzeug uebersetzt I=1:3 H=55mm

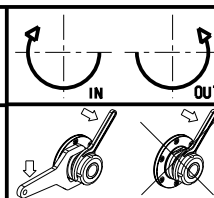

M.T. srl

Via Casino Albini 480
Tel. 0541/956034-957884
Fax 0541/956341
47842 S. GIOVANNI IN M. (RN)
e-mail: mtma@mtmarchetti.com
http://www.mtmarchetti.com

PRODUZIONE MODULI ROTANTI



PAGINA CMZ205-3-10

Subject to change without notice.

10/2018

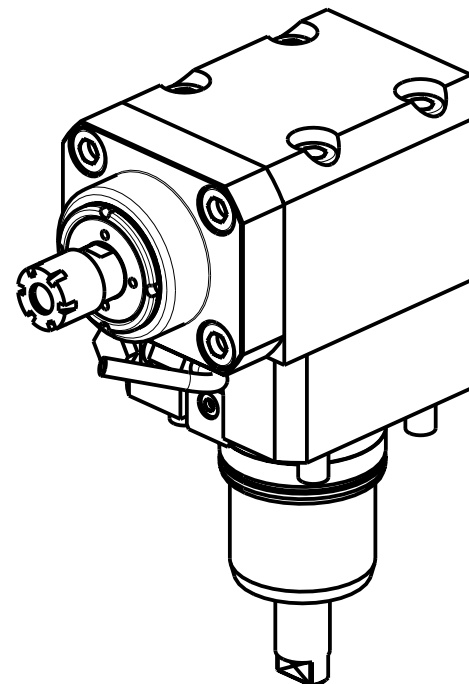
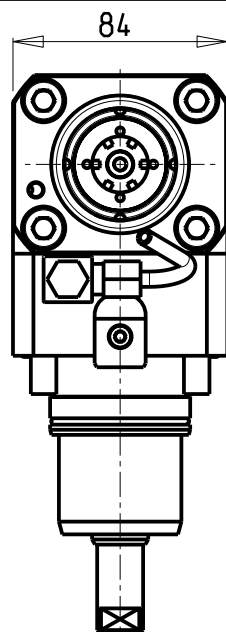
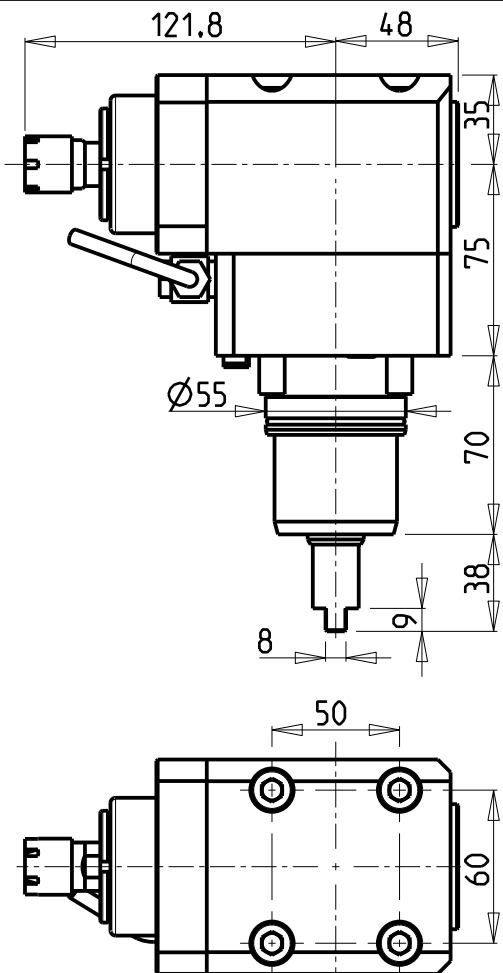

ATTENZIONE - ATTENTION - ACHTUNG

- Per lo smontaggio degli utensili utilizzare sempre la chiave di contrasto come indicato nel manuale d'uso.
- For disassembly of the tools use always the contrast key as mentioned in the user instructions.
- Fuer das Abmontieren der Werkzeuge immer den Gegenschlüssel benutzen wie in der Bedienungsanleitung erwaeht.

ATTENZIONE - ATTENTION - ACHTUNG

- PRIMA DI UTILIZZARE IL MOTORIZZATO CONSULTARE LE ISTRUZIONI ALLEGATE!
- BEFORE USING THE DRIVEN TOOL, PLEASE CHECK THE ENCLOSED INSTRUCTION SHEET!
- VOR DER BENUTZUNG DES ANGETRIEBENEN WERKZEUGES, DIE BEILIEGENDEN INSTRUKTIONEN DURCHLESEN!

ATTENZIONE - ATTENTION - ACHTUNG

- VERIFICARE LE MISURE DI INGOMBRO PER POSSIBILE INTERFERENZA SU ALCUNI MODELLI DI MACCHINE
- Please check the overall sizes for possible interferences on some machine models
- Bitte überprüfen sie das ausmass um mögliche interferenzen auf einigen maschinen modellen zu vermeiden

Cod. MT	Mandrino Spindle Spindel	I	RPM	Coppia Max Max Torque Max Drehmoment	Reversibile lato mandrino/contromandrino Reversible sub/main spindle side Umkehrbare Spindel-seite/Gegenspindel-seite	Lubrificazione est. Ext. coolant Aussenkuehlung	CHIAVI INCLUSE Keys included Schluessel einbegriffen	
NKM0050216	ER16	1:3	18000	10Nm	X	X	CHUB17	CHMNER16

CMZ

MOD: TX52 Y3/Y2 QUATTRO/Y2 TW IN - TX66 Y3/Y2 QUATTRO/Y2 TW IN

MODULO MOTORIZZATO ASSIALE MOLTIPLICATO I=1:3 H=75mm

Axial geared-up I=1:3 driven tool H=75mm

Axial angetriebenes Werkzeug uebersetzt I=1:3 H=75mm

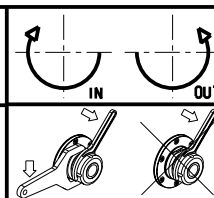

M.T. srl

Via Casino Albini 480
Tel. 0541/956034-957884
Fax 0541/956341
47842 S. GIOVANNI IN M. (RN)
e-mail: mtma@mtmarchetti.com
http://www.mtmarchetti.com

PRODUZIONE MODULI ROTANTI



PAGINA CMZ205-3-20

Subject to change without notice.

10/2018

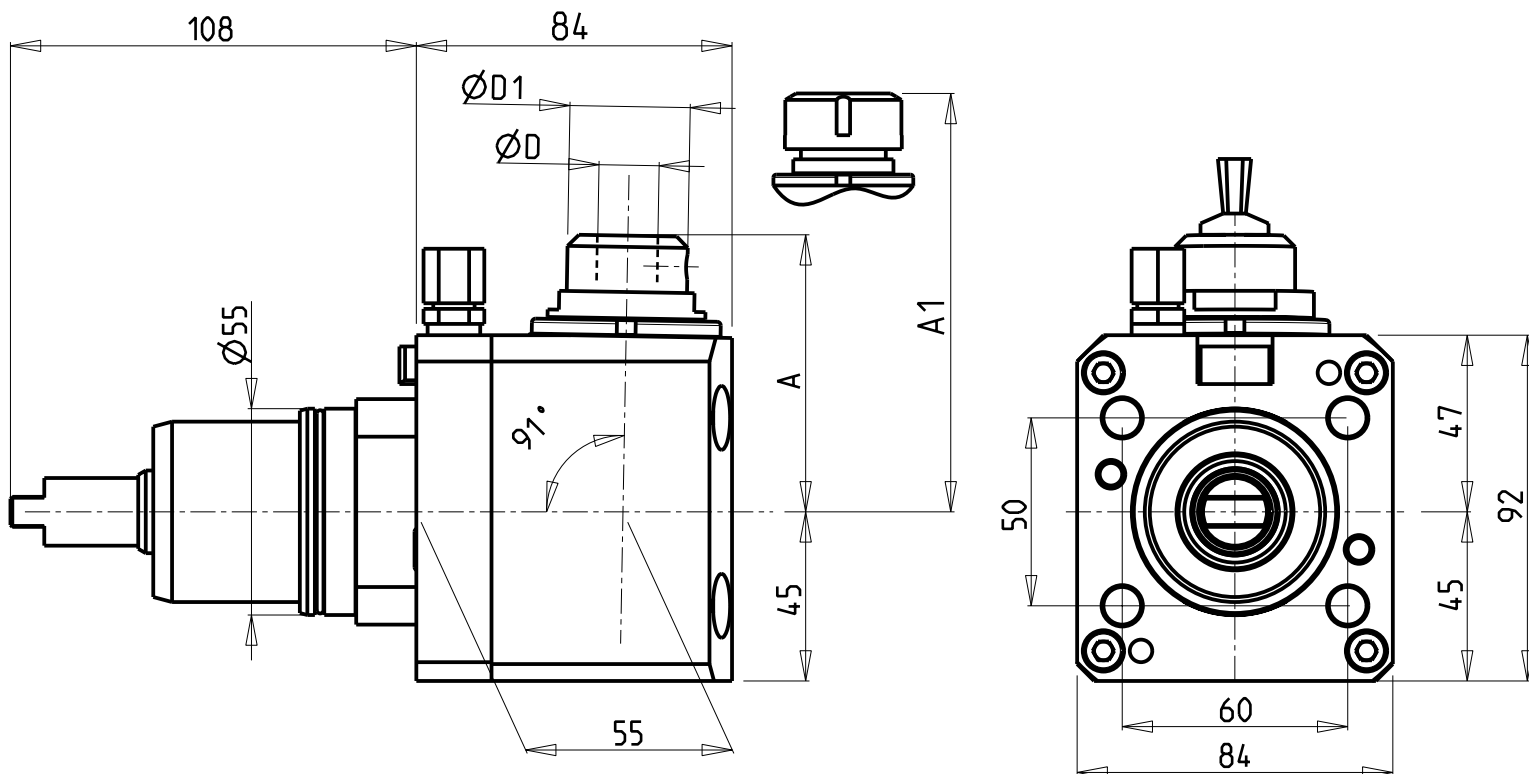

ATTENZIONE - ATTENTION - ACHTUNG

- Per lo smontaggio degli utensili utilizzare sempre la chiave di contrasto come indicato nel manuale d'uso.
- For disassembly of the tools use always the contrast key as mentioned in the user instructions.
- Fuer das Abmontieren der Werkzeuge immer den Gegenschlüssel benutzen wie in der Bedienungsanleitung erwaeht.

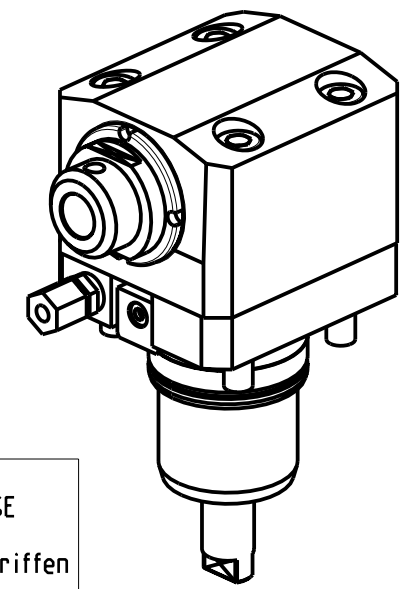

Cod. MT	Mandrino Spindle Spindel	i	RPM	Coppia Max Max Torque Max Drehmoment	Reversibile lato mandrino/contromandrino Reversible sub/main spindle side Umkehrbare Spindel-seite/ Gegenspindel-seite	Lubrificazione est. Ext. coolant Aussenkuehlung	A	A1	D	D1	CHIAVI NON INCLUSE Keys not included Schluessel nicht einbegriffen	
NKM0039125	ER25	1:1	6000	50Nm	X	X	-	80.44	-	-	CHUB36	CHSTER25
NKM0039108	WELDON 8	1:1	6000	50Nm	X	X	76.5	-	8	29	-	-
NKM0039110	WELDON 10	1:1	6000	50Nm	X	X	76.5	-	10	29	-	-
NKM0039112	WELDON 12	1:1	6000	50Nm	X	X	76.5	-	12	29	-	-
NKM0039116	WELDON 16	1:1	6000	50Nm	X	X	73.7	-	16	32	-	-

CMZ

MOD: TX52 Y3/Y2 QUATTRO/Y2 TW IN - TX66 Y3/Y2 QUATTRO/Y2 TW IN

MODULO MOTORIZZATO ASSIALE PER POLIGONATURA INTERNA H=55mm

Axial driven tool for internal polygon-making H=55mm

Axial angetriebenes Werkzeug fuer interne Facettierung H=55mm

Subject to change without notice.

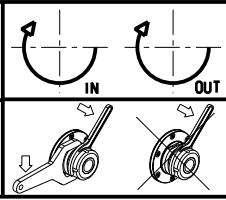

M.T. srl
 Via Casino Albini 480
 Tel. 0541/956034-957884
 Fax 0541/956341
 47842 S. GIOVANNI IN M. (RN)
 e-mail: mtma@mtmarchetti.com
 http://www.mtmarchetti.com

PRODUZIONE MODULI ROTANTI



PAGINA CMZ230-3-10

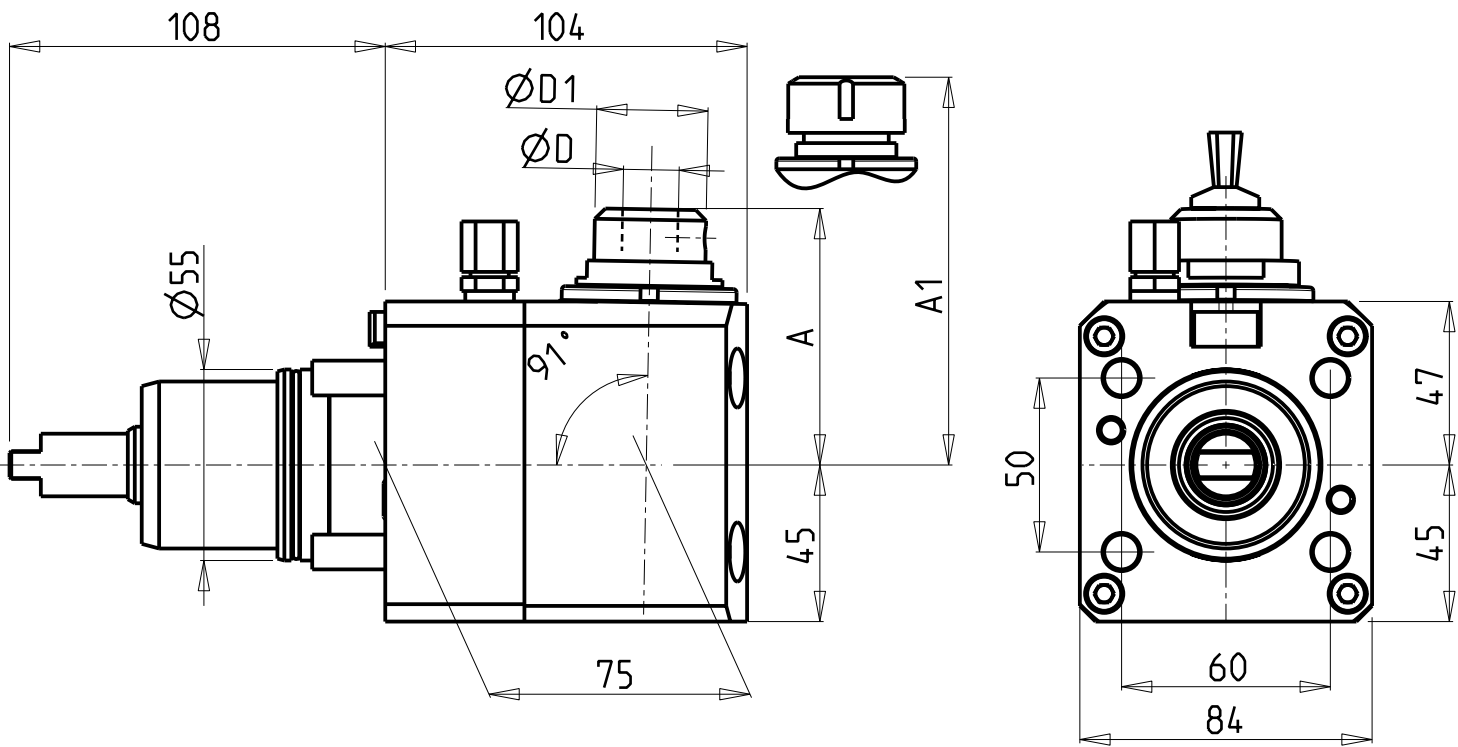

ATTENZIONE - ATTENTION - ACHTUNG

- Per lo smontaggio degli utensili utilizzare sempre la chiave di contrasto come indicato nel manuale d'uso.
- For disassembly of the tools use always the contrast key as mentioned in the user instructions.
- Fuer das Abmontieren der Werkzeuge immer den Gegenschlüssel benutzen wie in der Bedienungsanleitung erwaeht.

ATTENZIONE - ATTENTION - ACHTUNG

- VERIFICARE LE MISURE DI INGOMBRO PER POSSIBILE INTERFERENZA SU ALCUNI MODELLI DI MACCHINE
- Please check the overall sizes for possible interferences on some machine models
- Bitte überprüfen sie das ausmass um mögliche interferenzen auf einigen maschinen modellen zu vermeiden

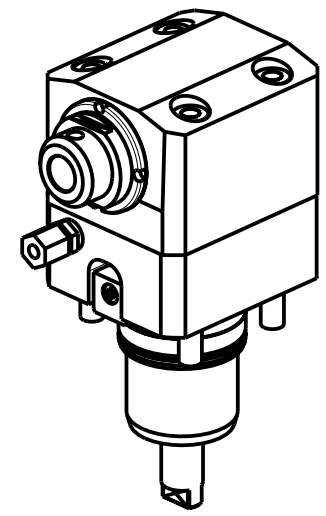

Cod. MT	Mandrino Spindle Spindel	I	RPM	Coppia Max Max Torque Max Drehmoment	Reversibile lato mandrino/contromandrino Reversible sub/main spindle side Umkehrbare Spindel-seite/ Gegenspindel-seite	Lubrificazione est. Ext. coolant Ausseukuhlung	A	A1	D	D1	CHIAVI NON INCLUSE Keys not included Schluessel nicht einbegriffen	
NKM0069125	ER25	1:1	6000	50Nm	X	X	-	80.44	-	-	CHUB36	CHSTER25
NKM0069108	WELDON 8	1:1	6000	50Nm	X	X	76.5	-	8	29	-	-
NKM0069110	WELDON 10	1:1	6000	50Nm	X	X	76.5	-	10	29	-	-
NKM0069112	WELDON 12	1:1	6000	50Nm	X	X	76.5	-	12	29	-	-
NKM0069116	WELDON 16	1:1	6000	50Nm	X	X	73.7	-	16	32	-	-

CMZ
 MOD: TX52 Y3/Y2 QUATTRO/Y2 TW IN - TX66 Y3/Y2 QUATTRO/Y2 TW IN

MODULO MOTORIZZATO ASSIALE PER POLIGONATURA INTERNA H=75mm
 Axial driven tool for internal polygon-making H=75mm
 Axial angetriebenes Werkzeug fuer interne Facettierung H=75mm

Subject to change without notice.

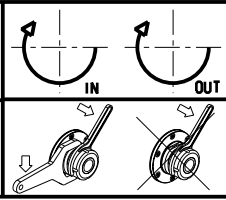

M.T. srl
 Via Casino Albini 480
 Tel. 0541/956034-957884
 Fax 0541/956341
 47842 S. GIOVANNI IN M. (RN)
 e-mail: mtma@mtmarchetti.com
 http://www.mtmarchetti.com

PRODUZIONE MODULI ROTANTI

 PAGINA CMZ230-3-20

ATTENZIONE - ATTENTION - ACHTUNG

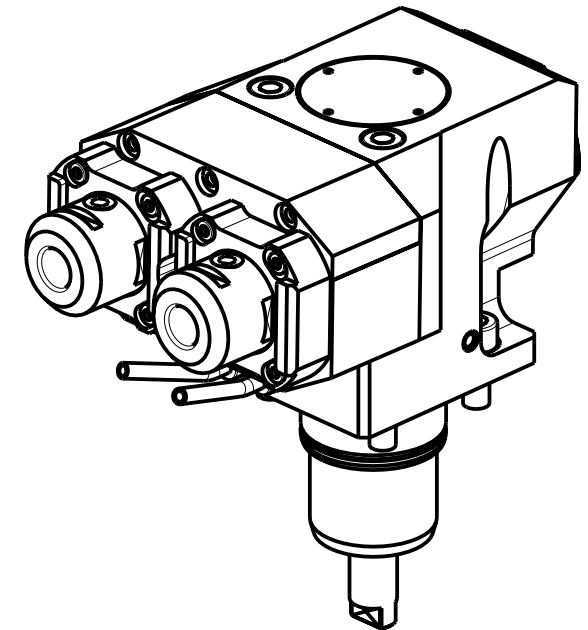
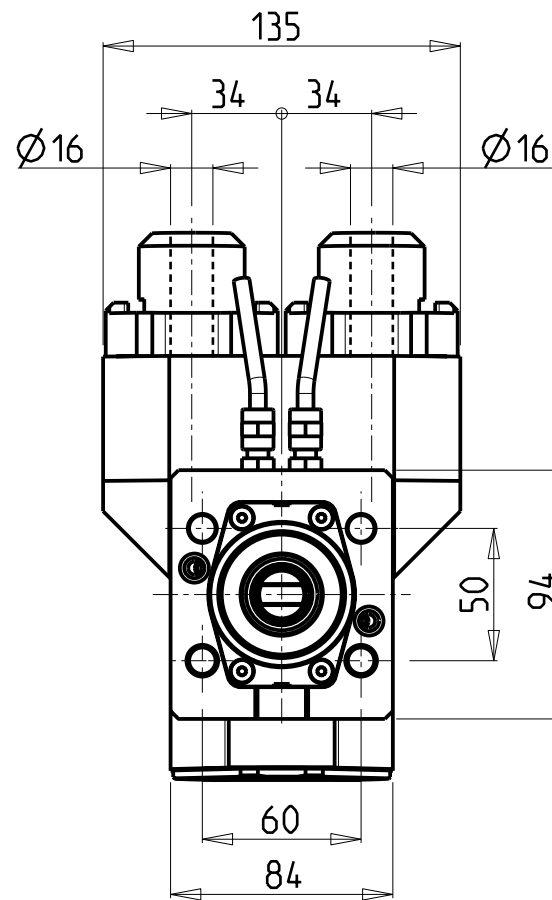
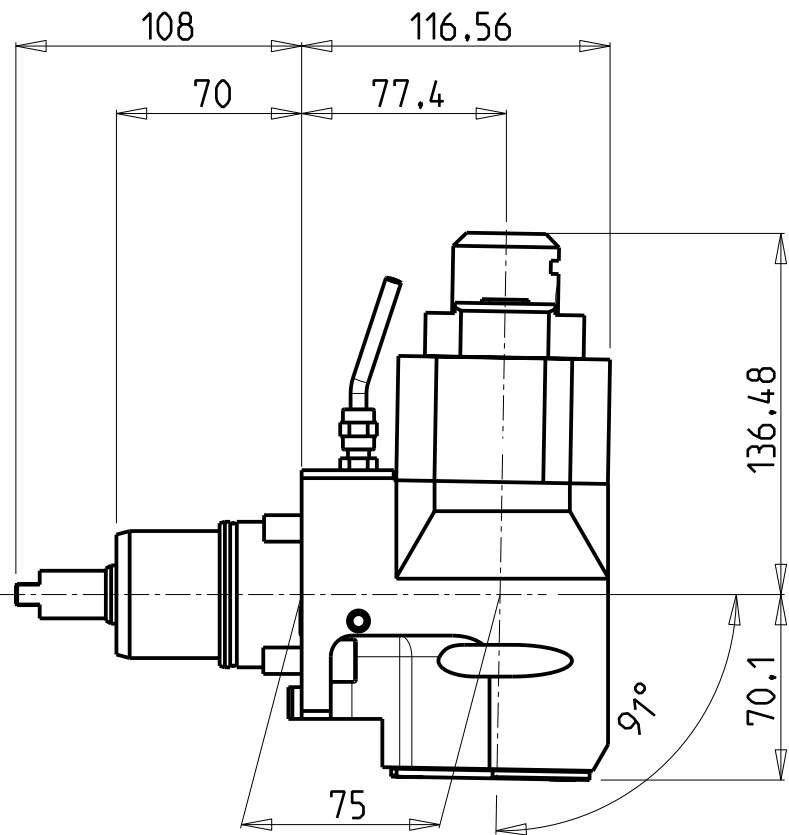
- VERIFICARE LE MISURE DI INGOMBRO PER POSSIBILE INTERFERENZA SU ALCUNI MODELLI DI MACCHINE
- Please check the overall sizes for possible interferences on some machine models
- Bitte überprüfen sie das ausmass um mögliche interferenzen auf einigen maschinen modellen zu vermeiden



Cod. MT	Mandrino Spindle Spindel	I	RPM	Coppia Max Max Torque Max Drehmoment	Reversibile lato mandrino/contromandrino Reversible sub/main spindle side Umkehrbare Spindel-seite/ Gegenspindel-seite	Lubr.esterna Ext. coolant Aussenkuehlung	CHIAVI INCLUSE Keys included Schlüssel inbegriffen
NKM1250616	WELDON 16	1:1	6000	30Nm	X	X	SAU0070027

CMZ

MOD: TX52 Y3/Y2 QUATTRO/Y2 TW IN - TX66 Y3/Y2 QUATTRO/Y2 TW IN

MODULO MOTORIZZATO ASSIALE 2 USCITE IN Y PER POLIGONATURA INTERNA H=75mm

Axial single side twin head driven tool in Y for internal polygon-making H=75mm

Axial angetriebenes Werkzeug 2 Ausgänge in Y fuer interne Facettierung H=75mm

Subject to change without notice.

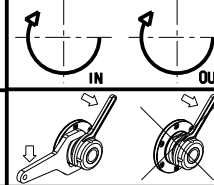

M.T. srl

Via Casino Albini 480
Tel. 0541/956034-957884

Fax 0541/956341

47842 S. GIOVANNI IN M. (RN)
e-mail: mtma@mtmarchetti.com
http://www.mtmarchetti.com

PRODUZIONE MODULI ROTANTI



PAGINA CMZ233-3-10

ATTENZIONE - ATTENTION - ACHTUNG

- Per lo smontaggio degli utensili utilizzare sempre la chiave di contrasto come indicato nel manuale d'uso.
- For disassembly of the tools use always the contrast key as mentioned in the user instructions.
- Fuer das Abmontieren der Werkzeuge immer den Gegenschlüssel benutzen wie in der Bedienungsanleitung erwaeht.

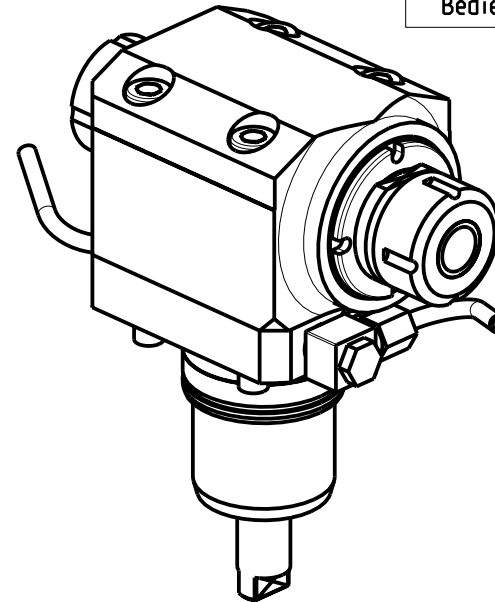
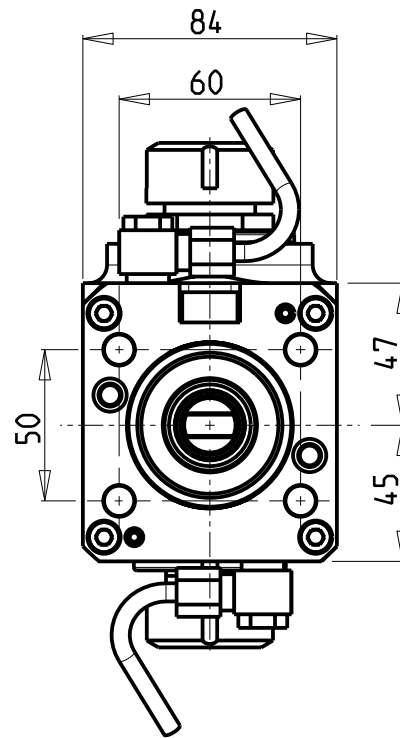
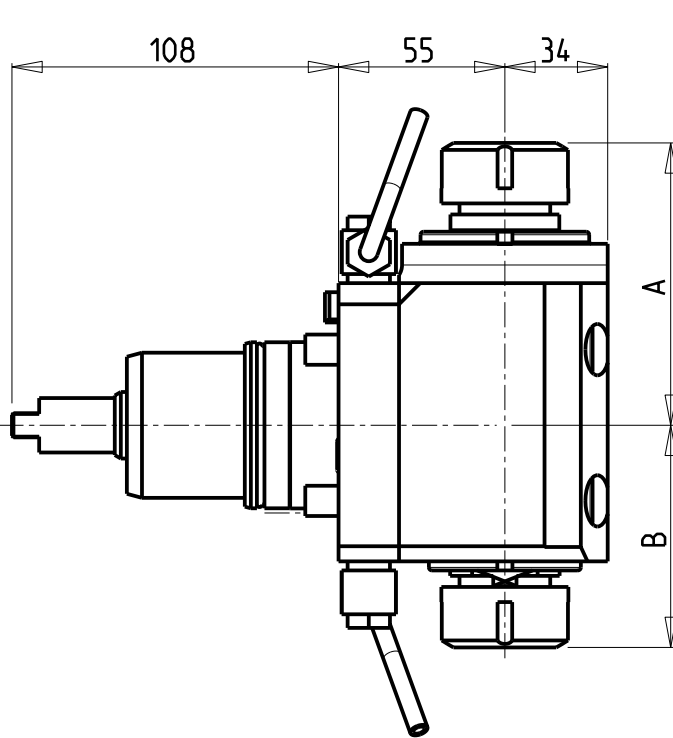

Cod. MT	Mandrino Spindle Spindel	I	RPM	Coppia Max Max Torque Max Drehmoment	Reversibile lato mandrino/contromandrino Reversible sub/main spindle side Umkehrbare Spindel-seite/ Gegenspindel-seite	Lubrificazione est. Ext. coolant Aussenkuehlung	A	B	CHIAVI NON INCLUSE Keys not included Schluessel nicht einbegriffen	
NKM0492525	ER25+ER25	1:1	6000	50Nm	X	X	93.36	73.46	CHSTER25	CHUB36+CHUB29
NKM0493232	ER32+ER32	1:1	6000	50Nm	X	X	100.56	78.96	CHSTER32	CHUB36

CMZ
 MOD: TX52 Y3/Y2 QUATTRO/Y2 TW IN - TX66 Y3/Y2 QUATTRO/Y2 TW IN
 MODULO MOTORIZZATO ASSIALE BISPORGENTE H=55mm
 Axial opposite face twin driven tool H=55mm
 Axial angetriebenes Werkzeug halb vorspringend H=55mm

M.T. srl
 Via Casino Albini 480
 Tel. 0541/956034-957884
 Fax 0541/956341
 47842 S. GIOVANNI IN M. (RN)
 e-mail: mtma@mtmarchetti.com
 http://www.mtmarchetti.com

PRODUZIONE MODULI ROTANTI

 PAGINA CMZ240-3-10

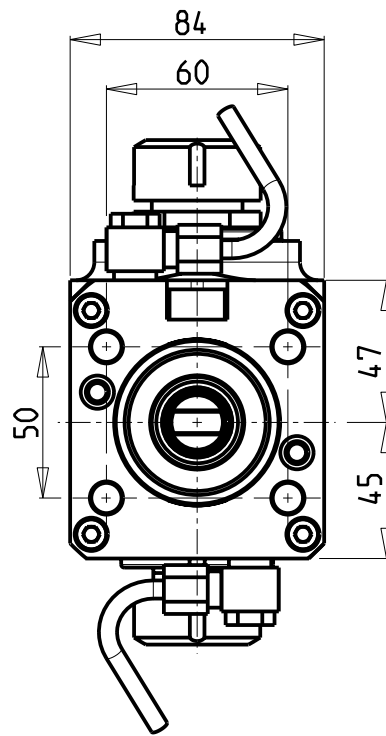
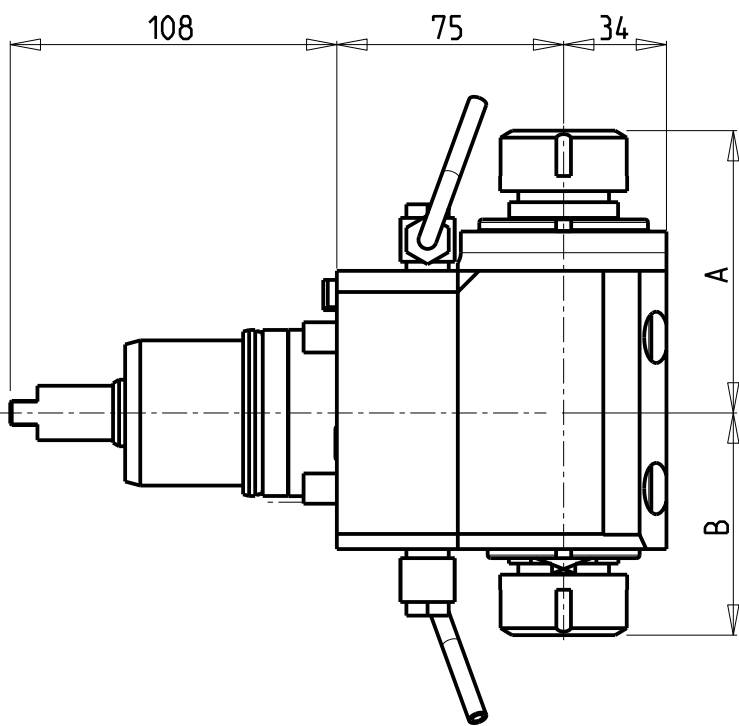
Subject to change without notice.



ATTENZIONE - ATTENTION - ACHTUNG

- Per lo smontaggio degli utensili utilizzare sempre la chiave di contrasto come indicato nel manuale d'uso.
- For disassembly of the tools use always the contrast key as mentioned in the user instructions.
- Fuer das Abmontieren der Werkzeuge immer den Gegenschlüssel benutzen wie in der Bedienungsanleitung erwäehnt.

ATTENZIONE - ATTENTION - ACHTUNG

- VERIFICARE LE MISURE DI INGOMBRO PER POSSIBILE INTERFERENZA SU ALCUNI MODELLI DI MACCHINE
- Please check the overall sizes for possible interferences on some machine models
- Bitte überprüfien sie das ausmass um mögliche interferenzen auf einigen maschinen modellen zu vermeiden

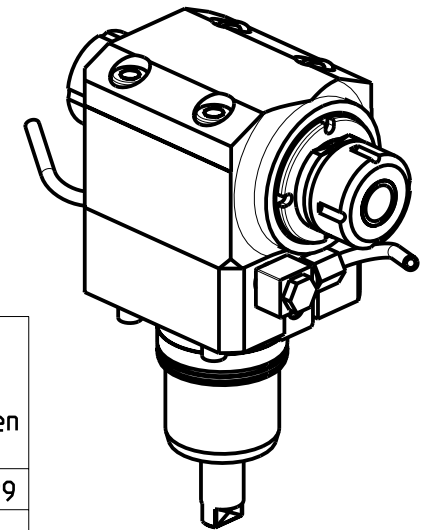

Cod. MT	Mandrino Spindle Spindel	I	RPM	Coppia Max Max Torque Max Drehmoment	Reversibile lato mandrino/contromandrino Reversible sub/main spindle side Umkehrbare Spindel-seite/ Gegenspindel-seite	Lubrificazione est. Ext. coolant Aussenkuehlung	A	B	CHIAVI NON INCLUSE Keys not included Schlüssel nicht einbegriffen	
									CHSTER25	CHUB36+CHUB29
NKM0502525	ER25+ER25	1:1	6000	50Nm	X	X	93.36	73.46	CHSTER25	CHUB36+CHUB29
NKM0503232	ER32+ER32	1:1	6000	50Nm	X	X	100.56	78.96	CHSTER32	CHUB36

CMZ
 MOD: TX52 Y3/Y2 QUATTRO/Y2 TW IN - TX66 Y3/Y2 QUATTRO/Y2 TW IN
 MODULO MOTORIZZATO ASSIALE BISPORGENTE H=75mm
 Axial opposite face twin driven tool H=75mm
 Axial angetriebenes Werkzeug halb vorspringend H=75mm

M.T. srl
 Via Casino Albini 480
 Tel. 0541/956034-957884
 Fax 0541/956341
 47842 S. GIOVANNI IN M. (RN)
 e-mail: mtma@tmarchetti.com
 http://www.tmmarchetti.com

PRODUZIONE MODULI ROTANTI



PAGINA CMZ240-3-20

ATTENZIONE - ATTENTION - ACHTUNG

- VERIFICARE LE MISURE DI INGOMBRO PER POSSIBILE INTERFERENZA SU ALCUNI MODELLI DI MACCHINE
- Please check the overall sizes for possible interferences on some machine models
- Bitte überprüfen sie das ausmass um mögliche interferenzen auf einigen maschinen modellen zu vermeiden

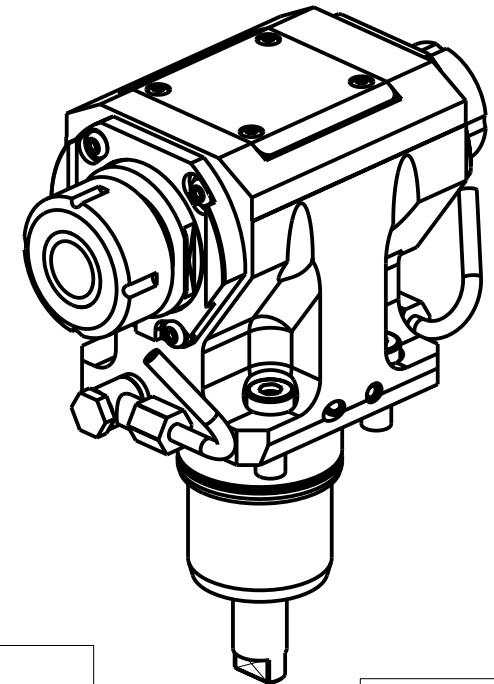
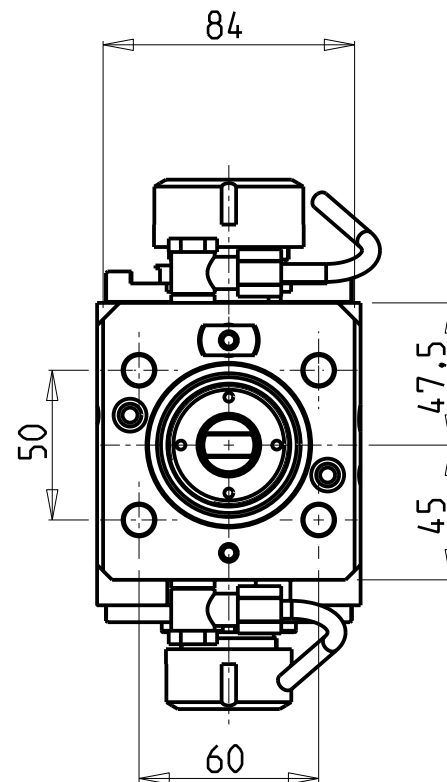
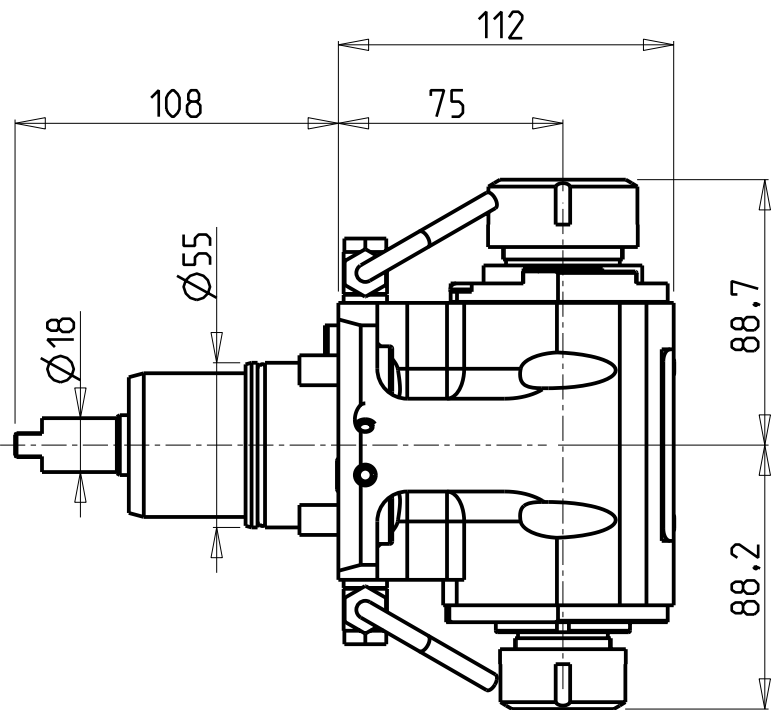

- Chiave inclusa
- Key included
- Schluessel inbegriffen

Cod. MT	Mandrino Spindle Spindel	I	RPM	Coppia Max Max Torque Max Drehmoment	Reversibile lato mandrino/contromandrino Reversible sub/main spindle side Umkehrbare Spindel-seite/ Gegenspindel-seite	Lubrificazione est. Ext. coolant Ausseinkuehlung	CHIAVI NON INCLUSE Keys not included Schluessel nicht einbegriffen		
NKM1403225	ER32+ER25	1:1	6000	50Nm	X	X	CHSTER32	CHSTER25	OKU0650004

CMZ
 MOD: TX52 Y3/Y2 QUATTRO/Y2 TWIN - TX66 Y3/Y2 QUATTRO/Y2 TWIN
 MODULO MOTORIZZATO ASSIALE BISPORGENTE H=75mm
 Axial opposite face twin driven tool H=75mm
 Axial angetriebenes Werkzeug halb vorspringend H=75mm

M.T. srl
 Via Casino Albini 480
 Tel. 0541/956034-957884
 Fax 0541/956341
 47842 S. GIOVANNI IN M. (RN)
 e-mail: mtma@mtmarchetti.com
 http://www.mtmarchetti.com

PRODUZIONE MODULI ROTANTI

 PAGINA CMZ240-3-21

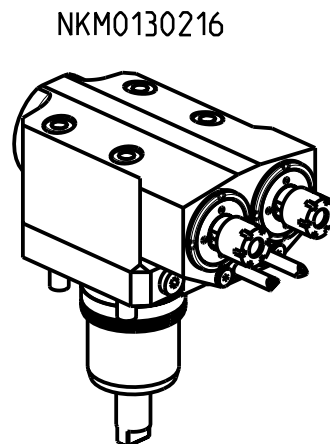
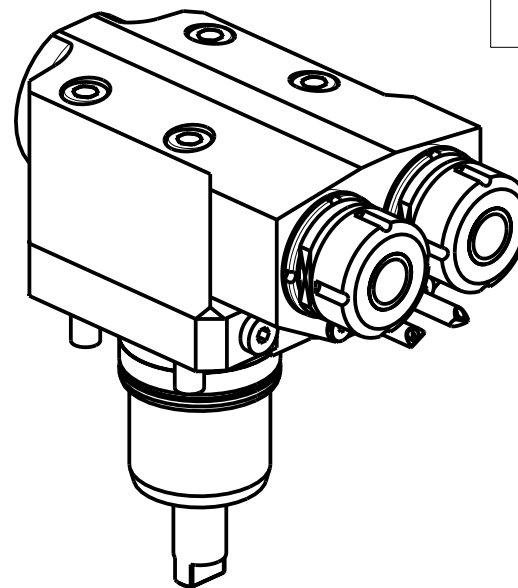
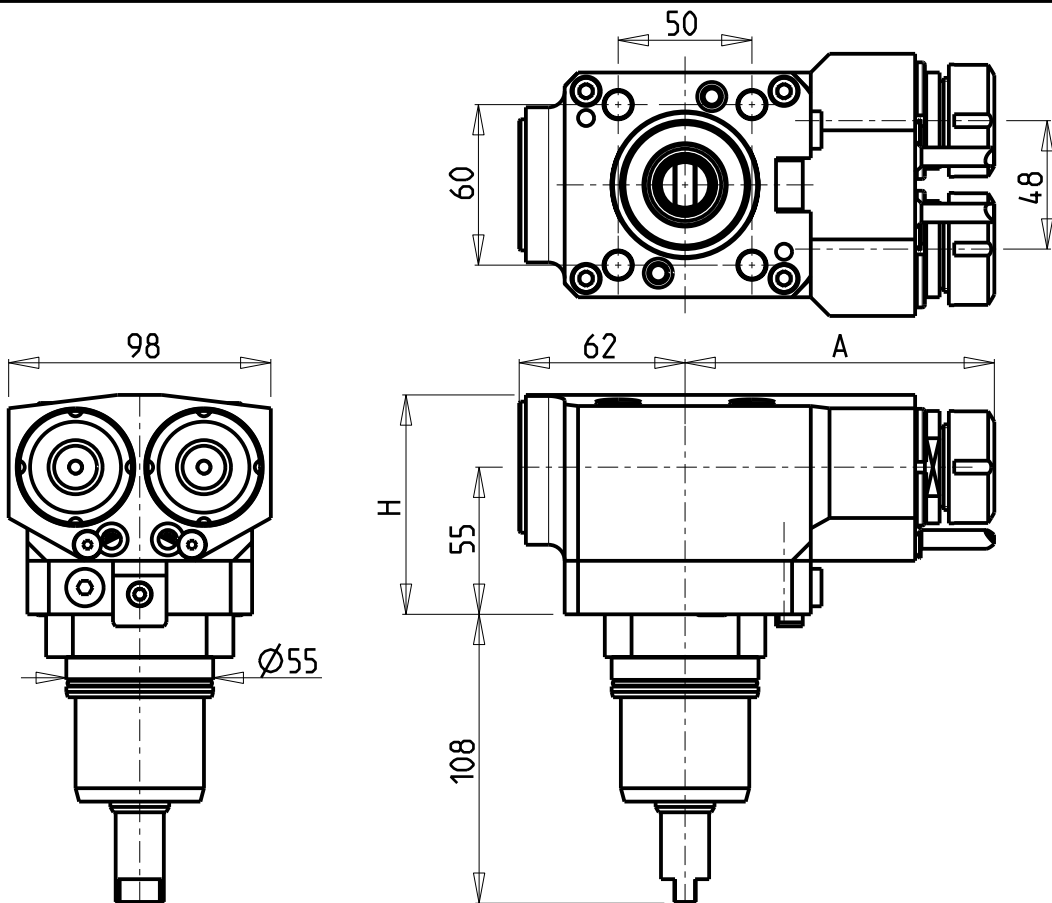
Subject to change without notice.



ATTENZIONE - ATTENTION - ACHTUNG

- Per lo smontaggio degli utensili utilizzare sempre la chiave di contrasto come indicato nel manuale d'uso.
- For disassembly of the tools use always the contrast key as mentioned in the user instructions.
- Fuer das Abmontieren der Werkzeuge immer den Gegenschlüssel benutzen wie in der Bedienungsanleitung erwaehnt.

Cod. MT	Mandrino Spindle Spindel	I	RPM	Coppia Max Max Torque Max Drehmoment	Reversibile lato mandrino/contromandrino Reversible sub/main spindle side Umkehrbare Spindel-seite/ Gegenspindel-seite	Lubrificazione int. Coolant through Innenkuehlung	Lubrificazione est. Ext. coolant Aussenkuehlung	A	H	CHIAVI NON INCLUSE Keys not included Schluesssel nicht einbegriffen	
NKM0130216	ER16	1:1	6000	30Nm	X	-	X	115.15	82	CHUB17	CHMNER16
NKM0130225	ER25	1:1	6000	30Nm	X	-	X	115.61	82	MNLO210007	CHSTER25
NKM0130425	ER25	1:1	6000	30Nm	X	P=70bar	X	128.11	87	MNLO210007	CHSTER25

NEW

CMZ

MOD: TX52 Y3/Y2 QUATTRO/Y2 TWIN - TX66 Y3/Y2 QUATTRO/Y2 TWIN

MODULO MOTORIZZATO ASSIALE 2 USCITE IN Y H=55mm

Axial single side twin head driven tool in Y H=55mm

Axial angetriebenes Werkzeug 2 Ausgaenge in Y H=55mm

Subject to change without notice.

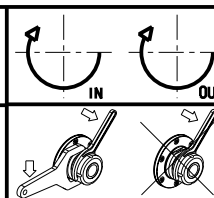

M.T. srl

Via Casino Albini 480
Tel. 0541/956034-957884

Fax 0541/956341

47842 S. GIOVANNI IN M. (RN)

e-mail: mtma@mtmarchetti.com

http://www.mtmarchetti.com

PRODUZIONE MODULI ROTANTI



PAGINA CMZ260-3-10

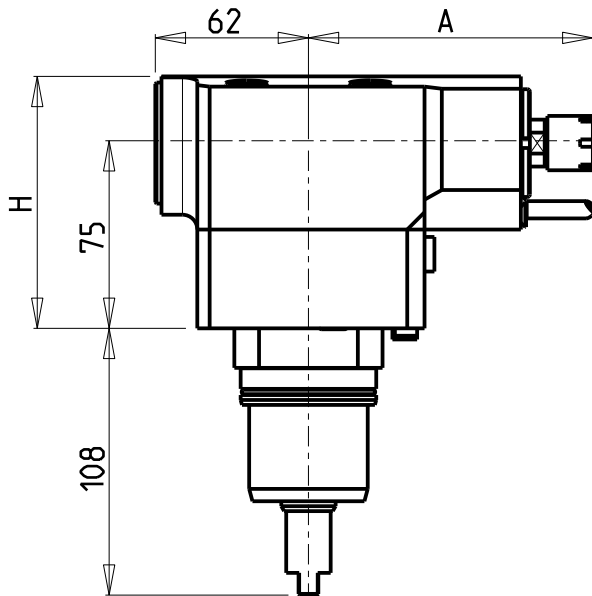
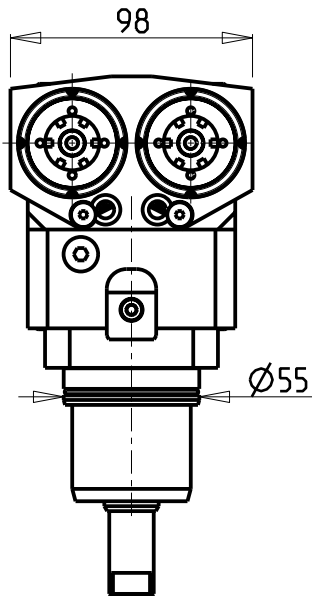
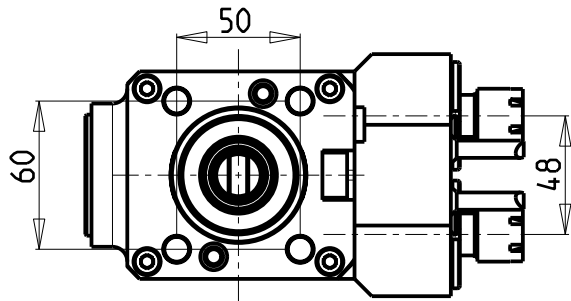

ATTENZIONE - ATTENTION - ACHTUNG

- VERIFICARE LE MISURE DI INGOMBRO PER POSSIBILE INTERFERENZA SU ALCUNI MODELLI DI MACCHINE
- Please check the overall sizes for possible interferences on some machine models
- Bitte überprüfen sie das ausmass um mögliche interferenzen auf einigen maschinen modellen zu vermeiden

ATTENZIONE - ATTENTION - ACHTUNG

- Per lo smontaggio degli utensili utilizzare sempre la chiave di contrasto come indicato nel manuale d'uso.
- For disassembly of the tools use always the contrast key as mentioned in the user instructions.
- Fuer das Abmontieren der Werkzeuge immer den Gegenschluessel benutzen wie in der Bedienungsanleitung erwaeht.

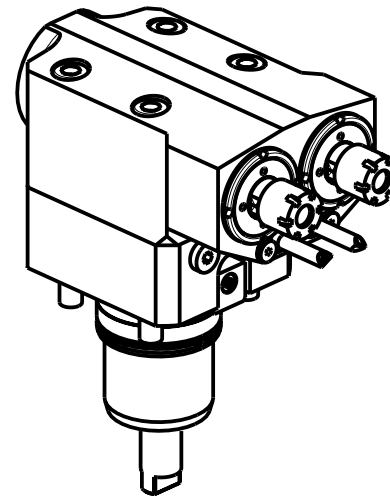

NKM0131225

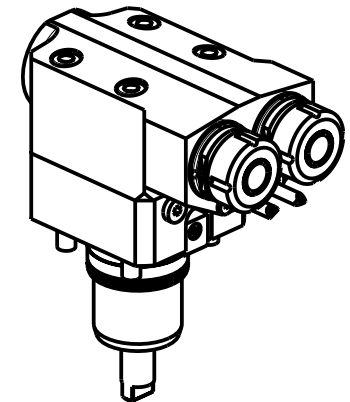

Cod. MT	Mandrino Spindle Spindel	I	RPM	Coppia Max Max Torque Max Drehmoment	Reversibile lato mandrino/contromandrino Reversible sub/main spindle side Umkehrbare Spindelsete/Gegenspindelsete	Lubrificazione int. Coolant through Innenkuehlung	Lubrificazione est. Ext. coolant Aussenkuehlung	A	H	CHIAVI NON INCLUSE Keys not included Schluessel nicht einbegriffen	
NKM0131216	ER16	1:1	6000	30Nm	X	-	X	115.15	102	CHUB17	CHMNER16
NKM0131225	ER25	1:1	6000	30Nm	X	-	X	115.61	102	MNLO210007	CHSTER25
NKM0131425	ER25	1:1	6000	30Nm	X	P=70bar	X	128.11	107	MNLO210007	CHSTER25

NEW

CMZ

MOD: TX52 Y3/Y2 QUATTRO/Y2 TWIN - TX66 Y3/Y2 QUATTRO/Y2 TWIN

MODULO MOTORIZZATO ASSIALE 2 USCITE IN Y H=75mm

Axial single side twin head driven tool in Y H=75mm

Axial angetriebenes Werkzeug 2 Ausgaenge in Y H=75mm

Subject to change without notice.

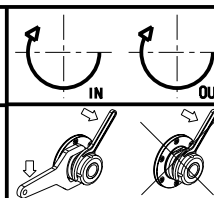

M.T. srl

Via Casino Albini 480
Tel. 0541/956034-957884
Fax 0541/956341
47842 S. GIOVANNI IN M. (RN)
e-mail: mtma@mtmarchetti.com
http://www.mtmarchetti.com

PRODUZIONE MODULI ROTANTI



PAGINA CMZ260-3-20

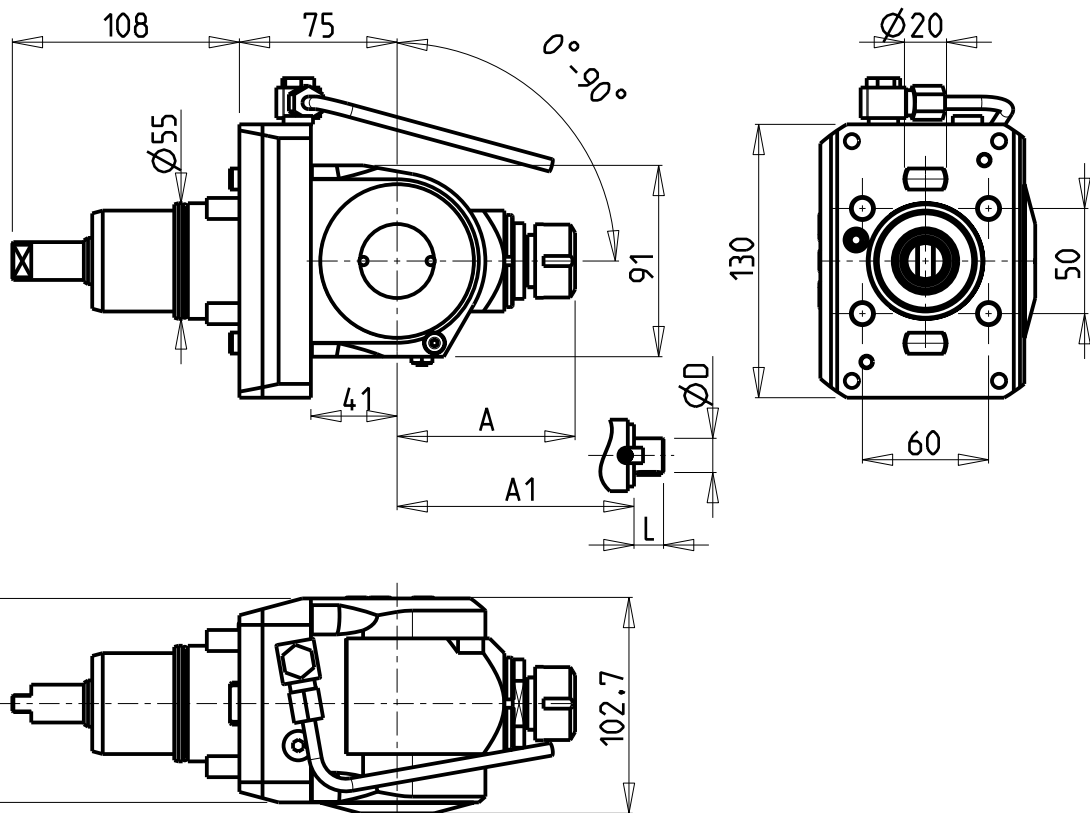

ATTENZIONE - ATTENTION - ACHTUNG

- FINO AD ESAURIMENTO SCORTE
- clearance sale
- solange vorrat

ATTENZIONE - ATTENTION - ACHTUNG

- Per lo smontaggio degli utensili utilizzare sempre la chiave di contrasto come indicato nel manuale d'uso.
- For disassembly of the tools use always the contrast key as mentioned in the user instructions.
- Fuer das Abmontieren der Werkzeuge immer den Gegenschlüssel benutzen wie in der Bedienungsanleitung erwäehnt.

ATTENZIONE - ATTENTION - ACHTUNG

- VERIFICARE LE MISURE DI INGOMBRO PER POSSIBILE INTERFERENZA SU ALCUNI MODELLI DI MACCHINE
- Please check the overall sizes for possible interferences on some machine models
- Bitte überprüfen sie das ausmass um mögliche interференzen auf einigen maschinen modellen zu vermeiden

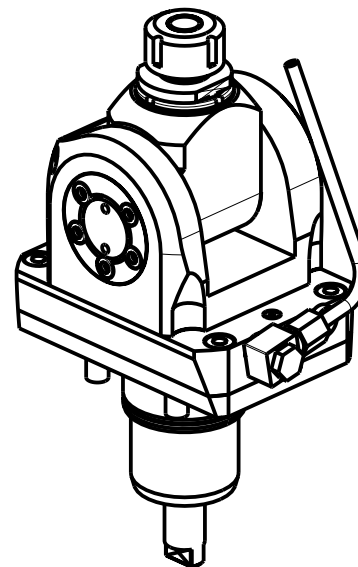

Cod. MT	Mandrino Spindle Spindel	I	RPM	Coppia Max Max Torque Max Drehmoment	Reversibile lato mandrino/contromandrino Reversible sub/main spindle side Umkehrbare Spindelsete/Gegenspindelsete	Lubrificazione est. Ext. coolant Aussenkuehlung	A	A1	D	L	CHIAVI INCLUSE Keys included Schluessel inbegriffen			
NKM0090020	ER20	1:1	6000	40Nm	X	X	84.16	-	-	-	CHSTER20	CHUB36	CHESL06	CHESL07
NKM0090025	ER25	1:1	6000	40Nm	X	X	85.66	-	-	-	CHSTER25	CHUB36	CHESL06	CHESL07
NKM0091617	Ø16x17	1:1	6000	40Nm	X	X	-	65	16	17	CH_VTCROCE_M08	CHUB36	CHESL06	CHESL07
NKM0092219	Ø22x19	1:1	6000	40Nm	X	X	-	66	22	19	CH_VTCROCE_M10	CHUB36	CHESL06	CHESL07
NKM0091905	Ø3/4"x3/4"	1:1	6000	40Nm	X	X	-	65	3/4"	3/4"	CH_VTCROCE_M08	CHUB36	CHESL06	CHESL07

CMZ

MOD: TX52 Y3/Y2 QUATTRO/Y2 TWIN - TX66 Y3/Y2 QUATTRO/Y2 TWIN

MODULO MOTORIZZATO ORIENTABILE 0-90°

0-90° adjustable angle driven tool

Angetriebenes Werkzeug schwenkbar 0-90°

Subject to change without notice.

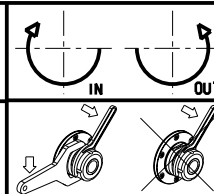

M.T. srl

Via Casino Albini 480
Tel. 0541/956034-957884
Fax 0541/956341

47842 S. GIOVANNI IN M. (RN)
e-mail: mtma@tmarchetti.com
http://www.tmmarchetti.com

PRODUZIONE MODULI ROTANTI



PAGINA CMZ330-3-00

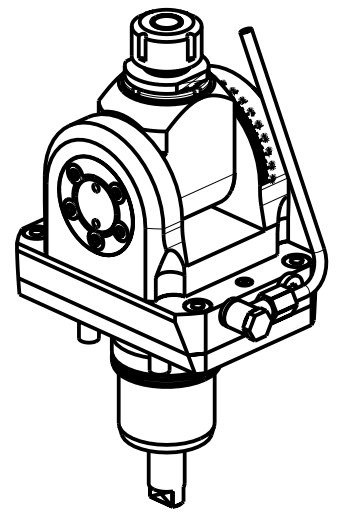
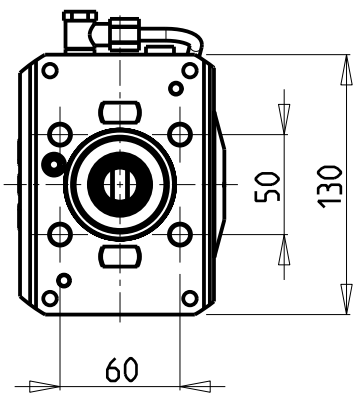
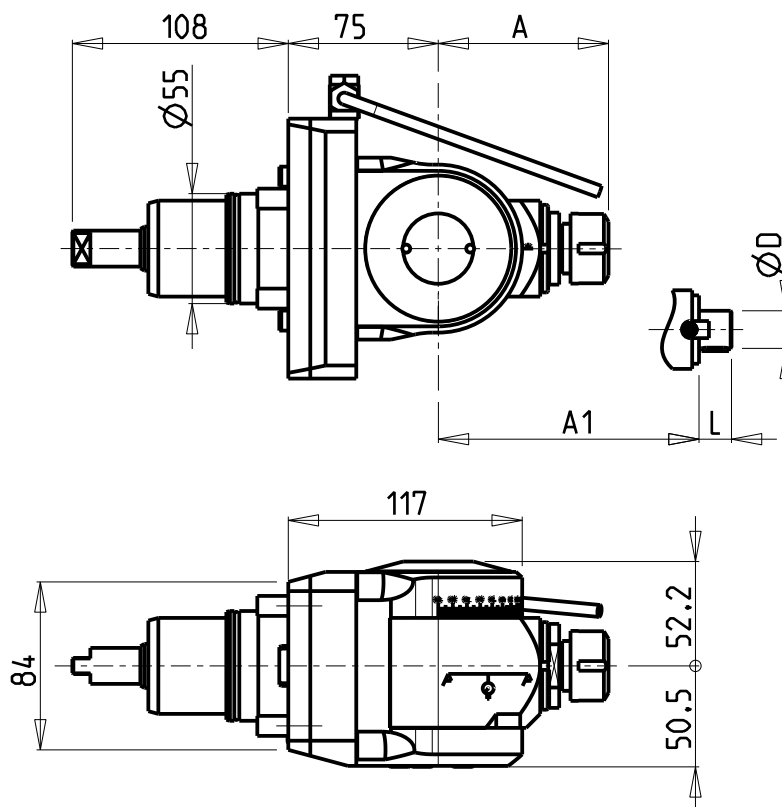

ATTENZIONE - ATTENTION - ACHTUNG

- Per lo smontaggio degli utensili utilizzare sempre la chiave di contrasto come indicato nel manuale d'uso.
- For disassembly of the tools use always the contrast key as mentioned in the user instructions.
- Fuer das Abmontieren der Werkzeuge immer den Gegenschlüssel benutzen wie in der Bedienungsanleitung erwaehtnt.

ATTENZIONE - ATTENTION - ACHTUNG

- Verificare la tabella sottostante per possibile interferenza su alcuni modelli di macchine
- Please check the table below for possible interferences on some machine models
- Die untenstehende tabelle unbedingt auf eventuelle interferenzen auf eingen maschinen modellen überprüfen

Cod. MT	Mandrino Spindle Spindel	I	RPM	Coppia Max Max Torque Max Drehmoment	Lubrificazione est. Ext. coolant Aussenkuehlung	A	A1	D	L	CHIAVI INCLUSE Keys included Schluessel inbegriffen			
NKM1260120	ER20	1:1	6000	40Nm	X	85.16	-	-	-	CHSTER20	CHUB36	CHESL06	CHESL07
NKM1260125	ER25	1:1	6000	40Nm	X	86.16	-	-	-	CHSTER25	CHUB36	CHESL06	CHESL07
NKM1260516	Ø16x17	1:1	6000	40Nm	X	-	65	16	17	CH_VTCROCE_M08	CHUB36	CHESL06	CHESL07
NKM1260522	Ø22x19	1:1	6000	40Nm	X	-	66	22	19	CH_VTCROCE_M10	CHUB36	CHESL06	CHESL07
NKM1260519	Ø3/4"x3/4"	1:1	6000	40Nm	X	-	65	3/4"	3/4"	CH_VTCROCE_M08	CHUB36	CHESL06	CHESL07

CMZ
 MOD: TX52 Y3/Y2 QUATTRO/Y2 TWIN - TX66 Y3/Y2 QUATTRO/Y2 TWIN
 MODULO MOTORIZZATO ORIENTABILE ±90°
 ±90° adjustable angle driven tool
 Angetriebenes Werkzeug schwenkbar ±90°

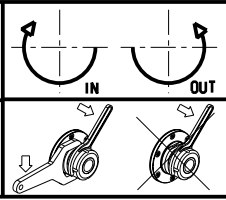

M.T. srl
 Via Casino Albini 480
 Tel. 0541/956034-957884
 Fax 0541/956341
 47842 S. GIOVANNI IN M. (RN)
 e-mail: mtma@mtmarchetti.com
 http://www.mtmarchetti.com

PRODUZIONE MODULI ROTANTI

 PAGINA CMZ333-3-00

Subject to change without notice.

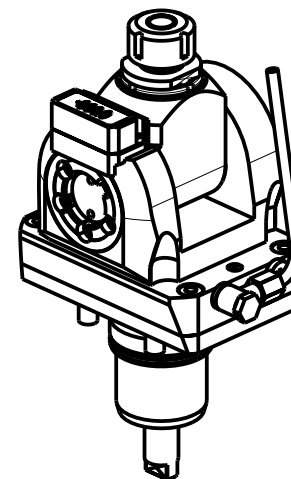
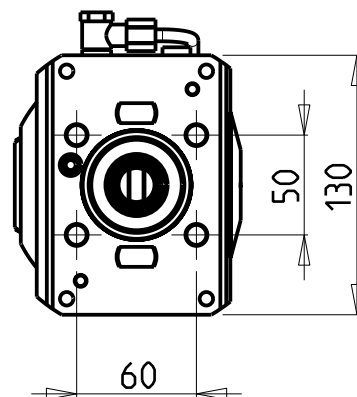
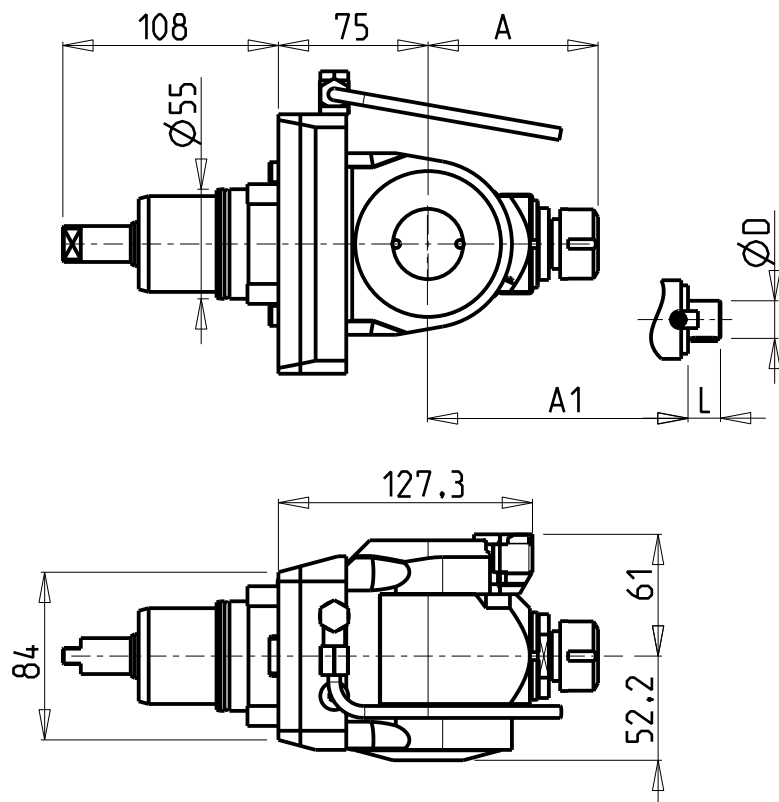

ATTENZIONE - ATTENTION - ACHTUNG

- Per lo smontaggio degli utensili utilizzare sempre la chiave di contrasto come indicato nel manuale d'uso.
- For disassembly of the tools use always the contrast key as mentioned in the user instructions.
- Fuer das Abmontieren der Werkzeuge immer den Gegenschlüssel benutzen wie in der Bedienungsanleitung erwaeht.

ATTENZIONE - ATTENTION - ACHTUNG

- Verificare la tabella sottostante per possibile interferenza su alcuni modelli di macchine
- Please check the table below for possible interferences on some machine models
- Die untenstehende tabelle unbedingt auf eventuelle interferenzen auf eingen maschinen modellen überprüfen

Cod. MT	Mandrino Spindle Spindel	I	RPM	Coppia Max Max Torque Max Drehmoment	Lubrificazione est. Ext. coolant Aussenkuehlung	A	A1	D	L	CHIAVI INCLUSE Keys included Schluessel inbegriffen			
NKM1220120	ER20	1:1	6000	40Nm	X	85.16	-	-	-	CHSTER20	CHUB36	CHESL06	CHESL07
NKM1220125	ER25	1:1	6000	40Nm	X	86.16	-	-	-	CHSTER25	CHUB36	CHESL06	CHESL07
NKM1220516	Ø16x17	1:1	6000	40Nm	X	-	65	16	17	CH_VTCROCE_M08	CHUB36	CHESL06	CHESL07
NKM1220522	Ø22x19	1:1	6000	40Nm	X	-	66	22	19	CH_VTCROCE_M10	CHUB36	CHESL06	CHESL07
NKM1220519	Ø3/4"x3/4"	1:1	6000	40Nm	X	-	65	3/4"	3/4"	CH_VTCROCE_M08	CHUB36	CHESL06	CHESL07

CMZ

MOD: TX52 Y3/Y2 QUATTRO/Y2 TWIN - TX66 Y3/Y2 QUATTRO/Y2 TWIN

MODULO MOTORIZZATO ORIENTABILE ±90° CON NONIO DIGITALE

±90° adjustable angle driven tool with digital display

Angetriebenes Werkzeug schwenkbar ±90° mit digital display

Subject to change without notice.

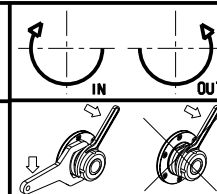

M.T. srl

Via Casino Albini 480
Tel. 0541/956034-957884
Fax 0541/956341
47842 S. GIOVANNI IN M. (RN)
e-mail: mtma@mtmarchetti.com
http://www.mtmarchetti.com

PRODUZIONE MODULI ROTANTI



PAGINA CMZ333-3-01

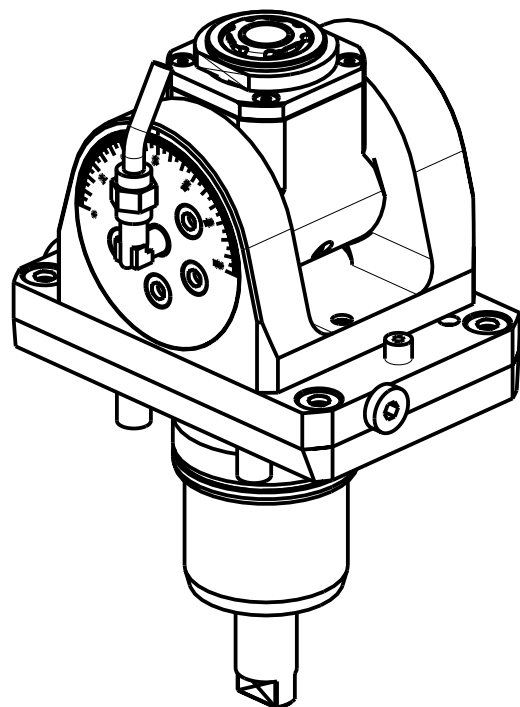
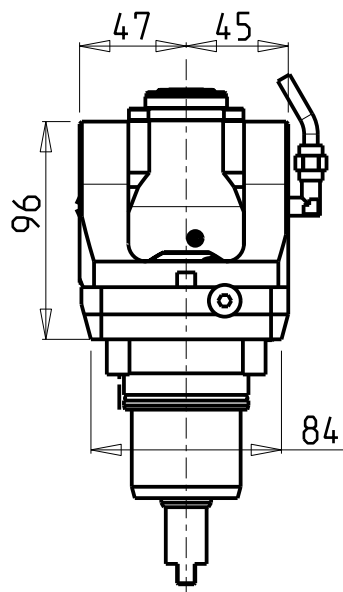
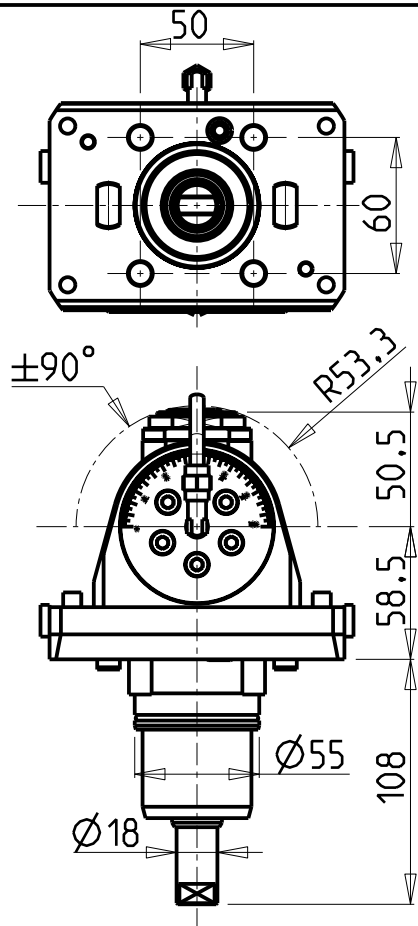

ATTENZIONE - ATTENTION - ACHTUNG

- Per lo smontaggio degli utensili utilizzare sempre la chiave di contrasto come indicato nel manuale d'uso.
- For disassembly of the tools use always the contrast key as mentioned in the user instructions.
- Fuer das Abmontieren der Werkzeuge immer den Gegenschlüssel benutzen wie in der Bedienungsanleitung erwaeht.

ATTENZIONE - ATTENTION - ACHTUNG

- Verificare la tabella sottostante per possibile interferenza su alcuni modelli di macchine
- Please check the table below for possible interferences on some machine models
- Die untenstehende tabelle unbedingt auf eventuelle interferenzen auf eingen maschinen modellen ueberpruefen

Cod. MT	Mandrino Spindle Spindel	i	RPM	Coppia Max Max Torque Max Drehmoment	Lubr.interna Coolant through Innenkuehlung	Lubrificazione est. Ext. coolant Aussenkuehlung	CHIAVI INCLUSE Keys included Schluessel inbegriffen				
							CHUB22	CHUB36	CHESL05	CHESL07	CHTAER20ZC
NKM0790120	ERA20	1:1	6000	30Nm		X	CHUB22	CHUB36	CHESL05	CHESL07	CHTAER20ZC
NKM0790220	ERA20	1:1	6000	30Nm	P=70bar	X	CHUB22	CHUB36	CHESL05	CHESL07	CHTAER20ZC

CMZ

MOD: TX52 Y3/Y2 QUATTRO/Y2 TW IN - TX66 Y3/Y2 QUATTRO/Y2 TW IN

MODULO MOTORIZZATO ORIENTABILE ±90°

±90° adjustable angle driven tool

Angetriebenes Werkzeug schwenkbar ±90°

Subject to change without notice.

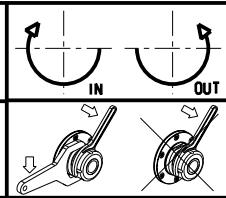

M.T. srl

Via Casino Albini 480
Tel. 0541/956034-957884
Fax 0541/956341

47842 S. GIOVANNI IN M. (RN)
e-mail: mtma@mtmarchetti.com
http://www.mtmarchetti.com

PRODUZIONE MODULI ROTANTI



PAGINA CMZ335-3-00

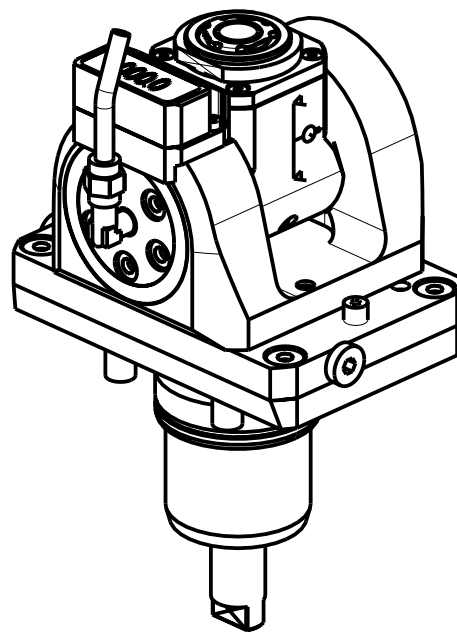
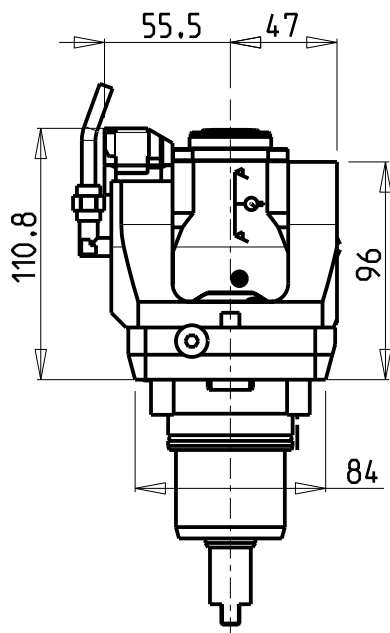
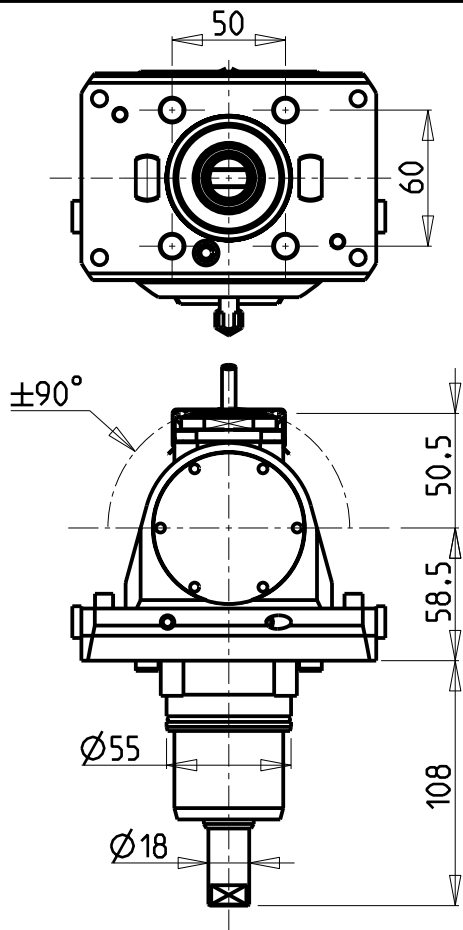

ATTENZIONE - ATTENTION - ACHTUNG

- Per lo smontaggio degli utensili utilizzare sempre la chiave di contrasto come indicato nel manuale d'uso.
- For disassembly of the tools use always the contrast key as mentioned in the user instructions.
- Fuer das Abmontieren der Werkzeuge immer den Gegenschlüssel benutzen wie in der Bedienungsanleitung erwaeht.

ATTENZIONE - ATTENTION - ACHTUNG

- Verificare la tabella sottostante per possibile interferenza su alcuni modelli di macchine
- Please check the table below for possible interferences on some machine models
- Die untenstehende tabelle unbedingt auf eventuelle interferenzen auf eingen maschinen modellen ueberpruefen

Cod. MT	Mandrino Spindle Spindel	I	RPM	Coppia Max Max Torque Max Drehmoment	Lubr.interna Coolant through Innenkuehlung	Lubrificazione est. Ext. coolant Aussenkuehlung	CHIAVI INCLUSE Keys included Schlüssel inbegriffen				
							CHUB22	CHUB36	CHESL05	CHESL07	CHTAER20ZC
NKM0795120	ERA20	1:1	6000	30Nm	-	X	CHUB22	CHUB36	CHESL05	CHESL07	CHTAER20ZC
NKM0795220	ERA20	1:1	6000	30Nm	P=70bar	X	CHUB22	CHUB36	CHESL05	CHESL07	CHTAER20ZC

CMZ

MOD: TX52 Y3/Y2 QUATTRO/Y2 TWIN - TX66 Y3/Y2 QUATTRO/Y2 TWIN

MODULO MOTORIZZATO ORIENTABILE ±90° CON NONIO DIGITALE

±90° adjustable angle driven tool with digital display

Angetriebenes Werkzeug schwenkbar ±90° mit digital display

Subject to change without notice.

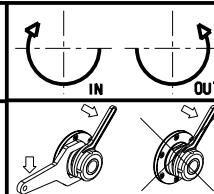

M.T. srl

Via Casino Albini 480
Tel. 0541/956034-957884
Fax 0541/956341

47842 S. GIOVANNI IN M. (RN)
e-mail: mtma@mtmarchetti.com
http://www.mtmarchetti.com

PRODUZIONE MODULI ROTANTI



PAGINA CMZ335-3-01

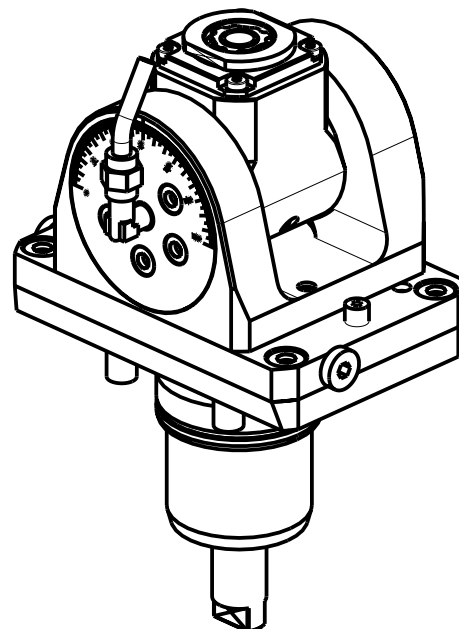
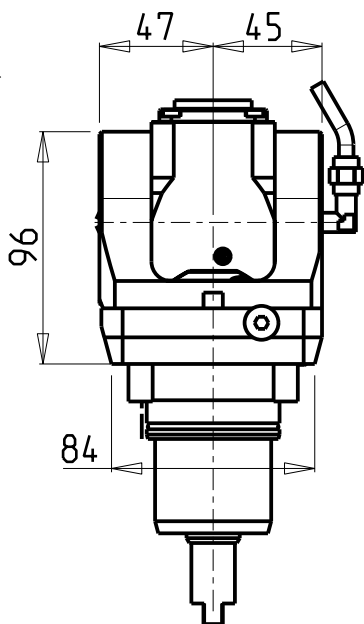
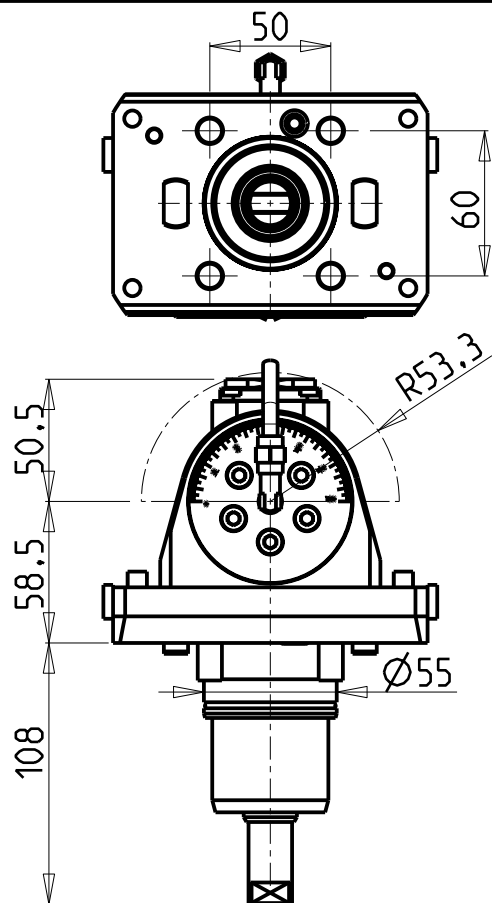

ATTENZIONE - ATTENTION - ACHTUNG

- Per lo smontaggio degli utensili utilizzare sempre la chiave di contrasto come indicato nel manuale d'uso.
- For disassembly of the tools use always the contrast key as mentioned in the user instructions.
- Fuer das Abmontieren der Werkzeuge immer den Gegenschlüssel benutzen wie in der Bedienungsanleitung erwäehnt.

ATTENZIONE - ATTENTION - ACHTUNG

- Verificare la tabella sottostante per possibile interferenza su alcuni modelli di macchine
- Please check the table below for possible interferences on some machine models
- Die untenstehende tabelle unbedingt auf eventuelle interferenzen auf eingen maschinen modellen überprüfen

Cod. MT	Mandrino Spindle Spindel	I	RPM	Coppia Max Max Torque Max Drehmoment	Lubr.interna Coolant through Innenkuehlung	Lubrificazione est. Ext. coolant Aussenkuehlung	CHIAVI INCLUSE Keys included Schluessel inbegriffen				
							CHUB19_SP3	CHUB32	CHESL05	CHESL07	CHTAER16ZC
NKM0790316	ERA16	1:2	12000	8Nm		X	CHUB19_SP3	CHUB32	CHESL05	CHESL07	CHTAER16ZC
NKM0790416	ERA16	1:2	12000	8Nm	P=70bar	X	CHUB19_SP3	CHUB32	CHESL05	CHESL07	CHTAER16ZC

CMZ

MOD: TX52 Y3/Y2 QUATTRO/Y2 TW IN - TX66 Y3/Y2 QUATTRO/Y2 TW IN

MODULO MOTORIZZATO ORIENTABILE +/-90° MOLTIPLICATO I=1:2

+/-90° adjustable angle driven tool geared-up I=1:2

Angetriebenes Werkzeug schwenkbar +/-90° uebersetzt I=1:2

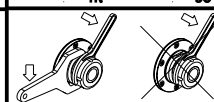
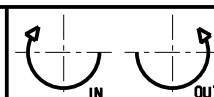

M.T. srl

Via Casino Albini 480
Tel. 0541/956034-957884

Fax 0541/956341

47842 S. GIOVANNI IN M. (RN)

e-mail: mtma@mtmarchetti.com

http://www.mtmarchetti.com

PRODUZIONE MODULI ROTANTI



PAGINA CMZ336-3-00

Subject to change without notice.

10/2018

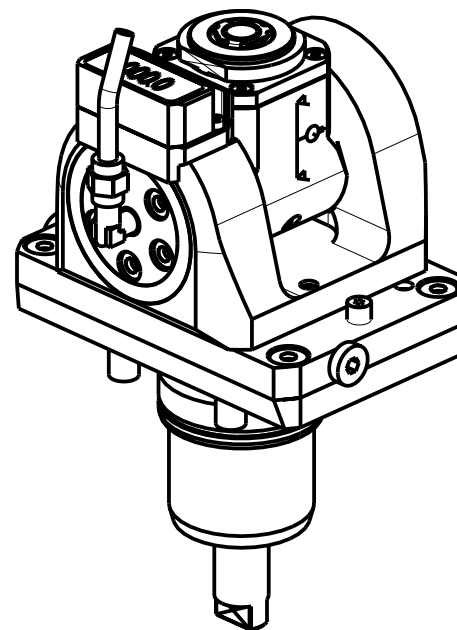
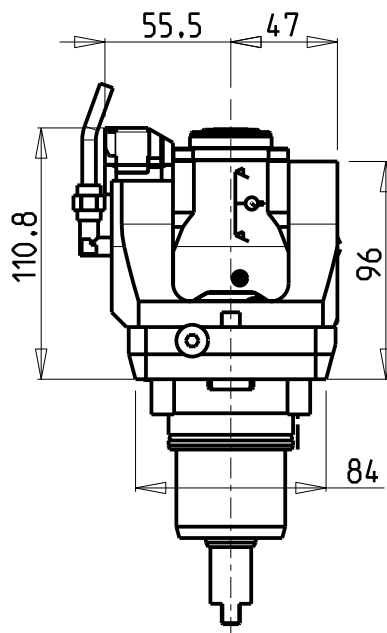
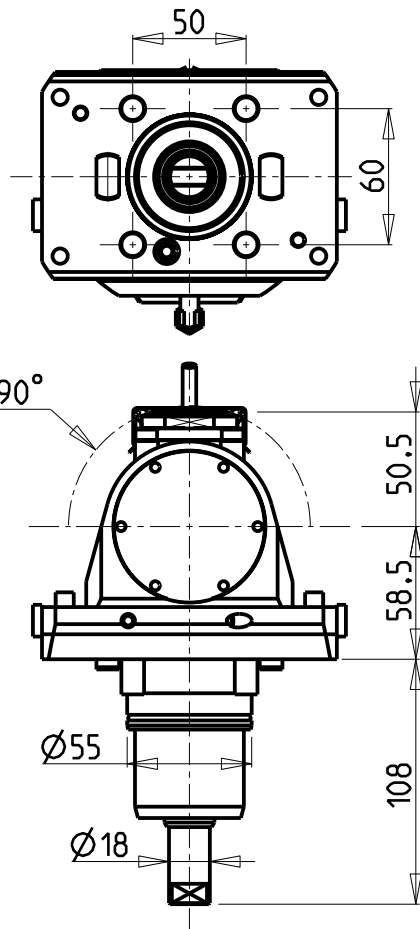

ATTENZIONE - ATTENTION - ACHTUNG

- Per lo smontaggio degli utensili utilizzare sempre la chiave di contrasto come indicato nel manuale d'uso.
- For disassembly of the tools use always the contrast key as mentioned in the user instructions.
- Fuer das Abmontieren der Werkzeuge immer den Gegenschlüssel benutzen wie in der Bedienungsanleitung erwaeht.

ATTENZIONE - ATTENTION - ACHTUNG

- Verificare la tabella sottostante per possibile interferenza su alcuni modelli di macchine
- Please check the table below for possible interferences on some machine models
- Die untenstehende tabelle unbedingt auf eventuelle interferenzen auf eingen maschinen modellen ueberpruefen

Cod. MT	Mandrino Spindle Spindel	I	RPM	Coppia Max Max Torque Max Drehmoment	Lubr.interna Coolant through Innenkuehlung	Lubrificazione est. Ext. coolant Aussenkuehlung	CHIAVI INCLUSE Keys included Schluessel inbegriffen				
NKM0795316	ERA16	1:2	12000	8Nm	-	X	CHUB19_SP3	CHUB32	CHESL05	CHESL07	CHTAER16ZC
NKM0795416	ERA16	1:2	12000	8Nm	P=70bar	X	CHUB19_SP3	CHUB32	CHESL05	CHESL07	CHTAER16ZC

CMZ

MOD: TX52 Y3/Y2 QUATTRO/Y2 TW IN - TX66 Y3/Y2 QUATTRO/Y2 TW IN

MODULO MOTORIZZATO ORIENTABILE +/-90° MOLTIPLICATO I=1:2 CON NONIO DIGITALE

+/-90° adjustable angle driven tool geared-up I=1:2 with digital display

Angetriebenes Werkzeug schwenkbar +/-90° uebersetzt I=1:2 mit digital display

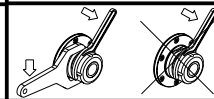

M.T. srl

Via Casino Albini 480
Tel. 0541/956034-957884
Fax 0541/956341

47842 S. GIOVANNI IN M. (RN)
e-mail: mtma@mtmarchetti.com
http://www.mtmarchetti.com

PRODUZIONE MODULI ROTANTI



PAGINA CMZ336-3-01

Subject to change without notice.

10/2018

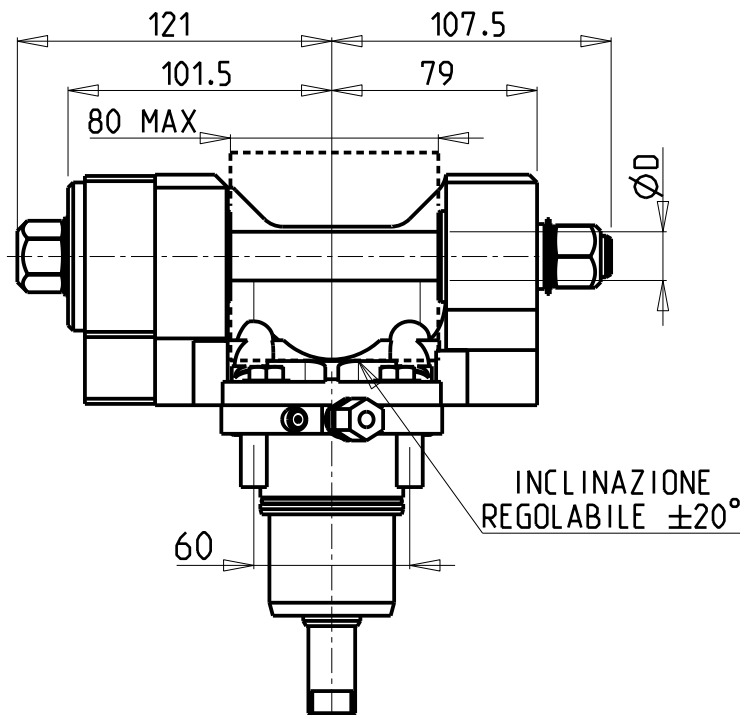
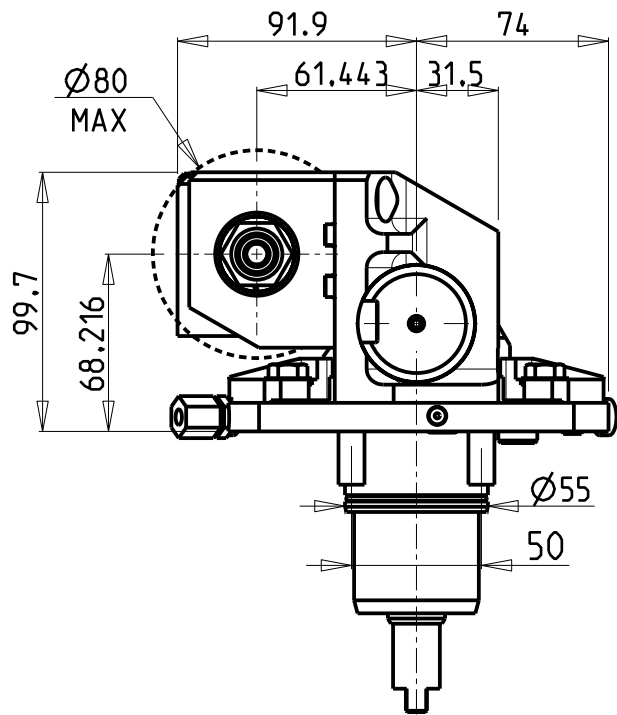

ATTENZIONE - ATTENTION - ACHTUNG

- Verificare la tabella sottostante per possibile interferenza su alcuni modelli di macchine
- Please check the table below for possible interferences on some machine models
- Die untenstehende tabelle unbedingt auf eventuelle interferenzen auf eingen maschinen modellen überprüfen

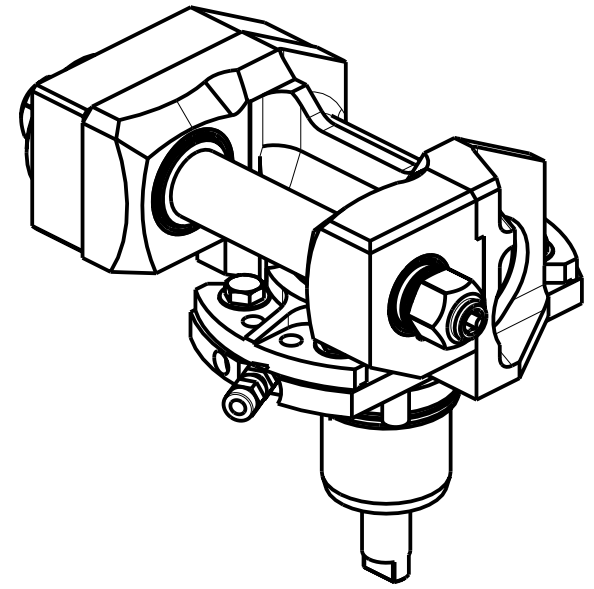

DOTAZIONI - SUPPLIED WITH - AUSSTATTUNG

mm / inch	- N°1 ALBERO + DISTANZIALI - N°1 SHAFT + SPACER - N°1 DORN + ABSTANDSSTUECK
-----------	---

PER ALBERI E DISTANZIALI VEDI PAG. TBL250-1-00
FOR SHAFT END SPACER SEE PAGE TBL250-1-00
FUER DORN UND ABSTANDSSTUECK SEITE TBL250-1-00

Cod. MT	I	RPM max	Coppia Max Max Torque Max Drehmoment	Reversibile lato mandrino/contromandrino Reversible sub/main spindle side Umkehrbare Spindel-seite/ Gegenspindel-seite	Lubrificazione est. Ext. coolant Aussenkuehlung	D (mm)	D (Inch)	CHIAVI INCLUSE Keys included Schlüssel inbegriffen			
								CHUB13	CHUB24	CHESL08	CHESL07
NKM0081100	1:1	6000	60Nm	X	X	16-22-27-32	3/4"-1"-1 1/4"	CHUB13	CHUB24	CHESL08	CHESL07
NKM0082100	2:1	3000	80Nm	X	X	16-22-27-32	3/4"-1"-1 1/4"	CHUB13	CHUB24	CHESL08	CHESL07

CMZ
MOD: TX52 Y3/Y2 QUATTRO/Y2 TW IN - TX66 Y3/Y2 QUATTRO/Y2 TW IN

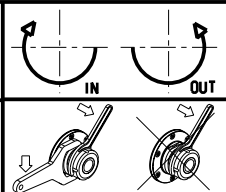

M.T. srl
Via Casino Albini 480
Tel. 0541/956034-957884
Fax 0541/956341
47842 S. GIOVANNI IN M. (RN)
e-mail: mtma@mtmarchetti.com
http://www.mtmarchetti.com

PRODUZIONE MODULI ROTANTI



PAGINA CMZ340-3-00

MODULO MOTORIZZATO PORTACREATORE
Driven gear hobber
Angetriebenes Zahnradwalzfräse-Werkzeug
Subject to change without notice.

ATTENZIONE - ATTENTION - ACHTUNG

- VERIFICARE LE MISURE DI INGOMBRO PER POSSIBILE INTERFERENZA SU ALCUNI MODELLI DI MACCHINE
- Please check the overall sizes for possible interferences on some machine models
- Bitte überprüfen sie das ausmass um mögliche interferenzen auf einigen maschinen modellen zu vermeiden

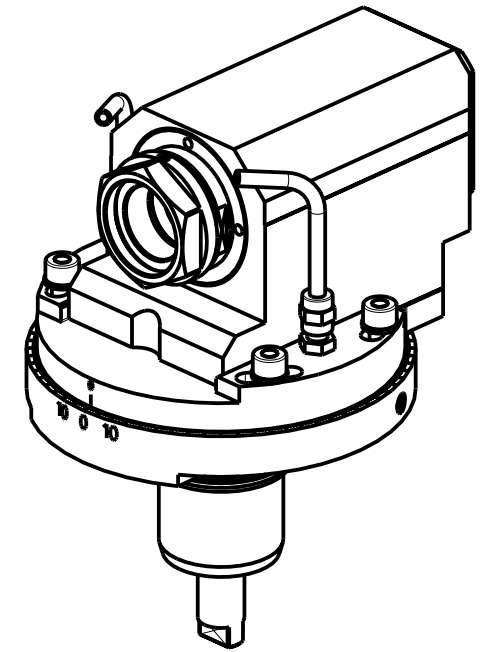
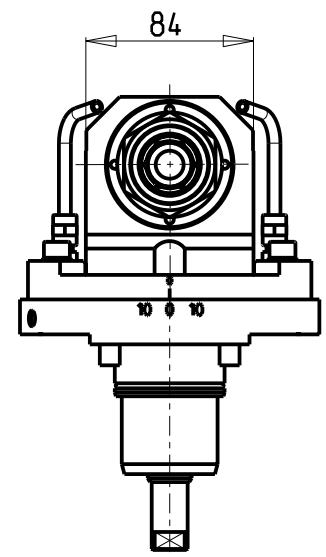
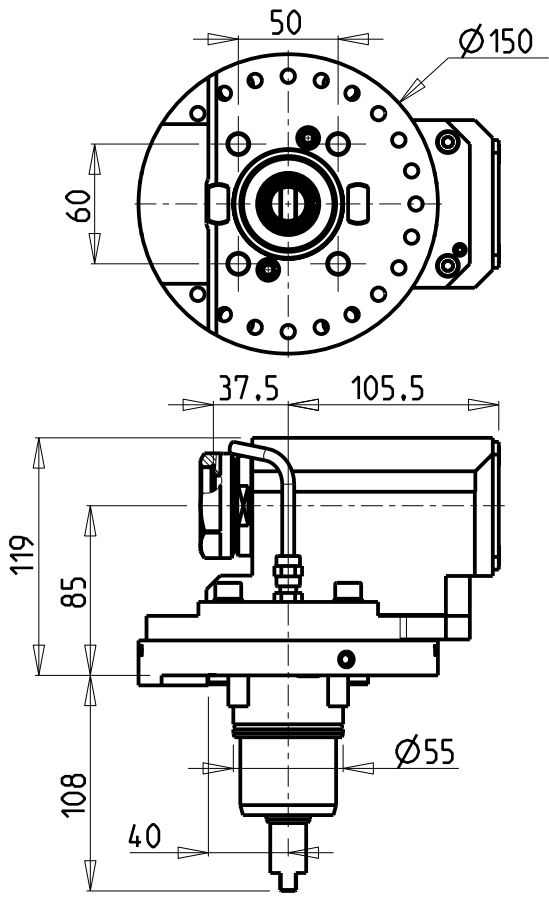

PER PORTAUTENSILI MODULARI MTSK-40 VEDI PAG. TBL300-1-40
 FOR MTSK-40 QUICK CHANGE TOOLHOLDERS CLAMPINGS SEE PAGE TBL300-1-40
 FUER MTSK-40 MODULARE WERKZEUGAUFNAHMEN SIEHE SEITE TBL300-1-40

Cod. MT	Mandrino Spindle Spindel	I	RPM	Coppia Max Max Torque Max Drehmoment	Reversibile lato mandrino/contromandrino Reversible sub/main spindle side Umkehrbare Spindel-seite/Gegenspindel-seite	Lubr.esterna Ext. coolant Aussenkuehlung	CHIAVI INCLUDE Keys included Schluessel einbegriffen
NKM1240100	MTSK-40	1:1	6000	50Nm	X	X	n°2 CHUB46

CMZ
 MOD: TX52 Y3/Y2 QUATTRO/Y2 TW IN - TX66 Y3/Y2 QUATTRO/Y2 TW IN

MODULO MOTORIZZATO ASSIALE MTSK PER POWER SKIVING H=85mm
 Axial MTSK driven tool for Power Skiving H=85mm
 Axial MTSK angetriebenes Werkzeug fuer Power Skiving H=85mm

Subject to change without notice.

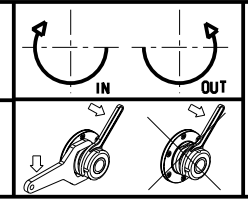

M.T. srl
 Via Casino Albini 480
 Tel. 0541/956034-957884
 Fax 0541/956341
 47842 S. GIOVANNI IN M. (RN)
 e-mail: mtma@mtmarchetti.com
 http://www.mtmarchetti.com

PRODUZIONE MODULI ROTANTI



PAGINA CMZ350-3-00-K

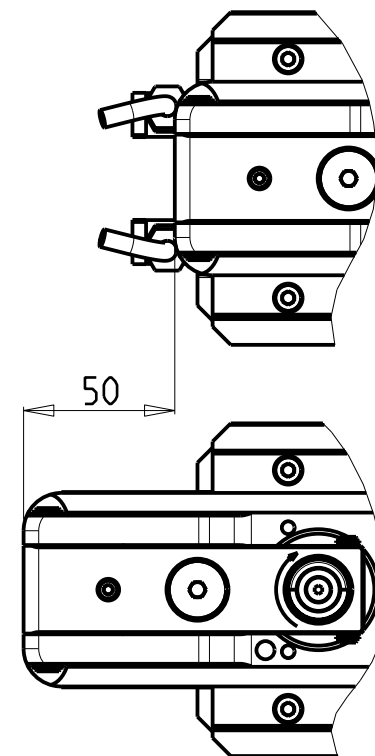
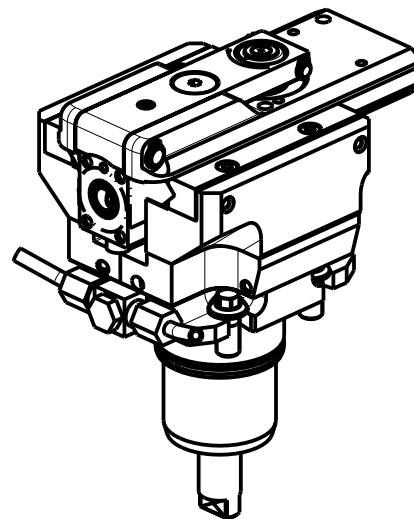
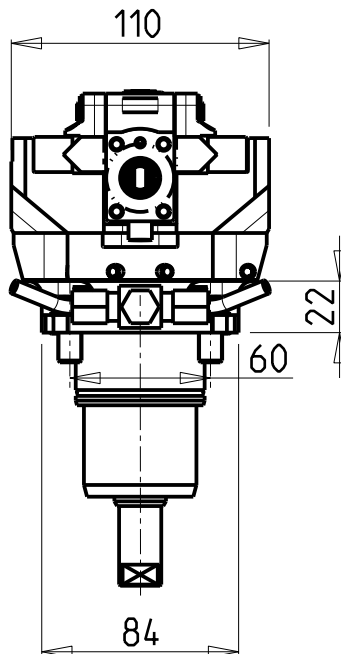
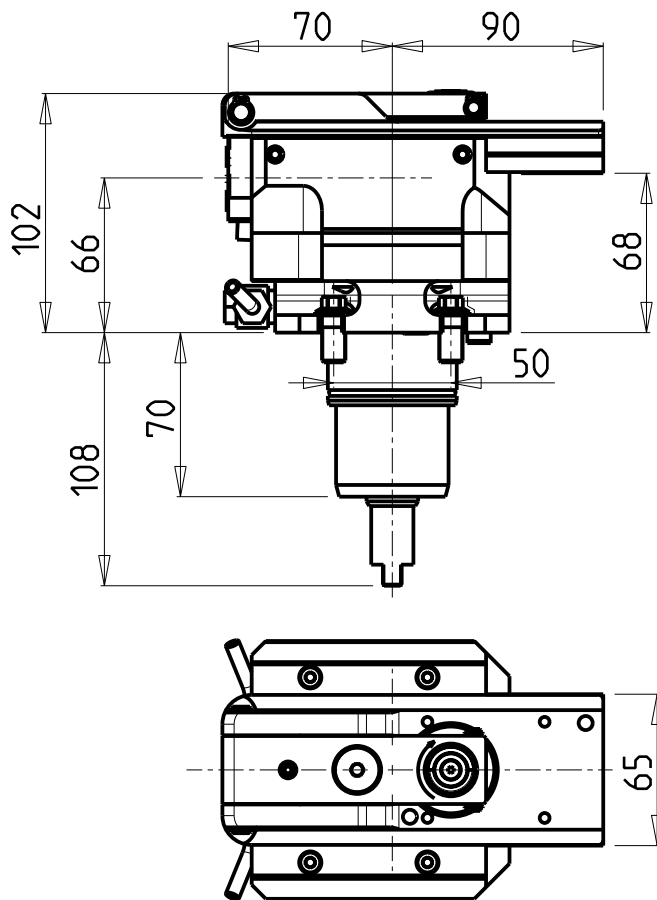

PER UTENSILI STOZZATORI VEDI PAG. TBL400-1-00
 FOR DRIVEN SLOTTING TOOL CUTTING-TOOLS SEE PAGE TBL400-1-00
 FÜR NUTENSTOSS-WERKZEUG SCHNEIDWERKZEUGE SIEHE SEITE TBL400-1-00

Cod. MT	I	RPM MAX	Reversibile lato mandrino/contromandrino Reversible sub/main spindle side Umkehrbare Spindel-seite/ Gegenspindel-seite	Lubr. esterna Ext. coolant Aussenkuehlung
NKM0910100	4:1	2000	X	X

CMZ

MOD: TX52 Y3/Y2 QUATTRO/Y2 TW IN - TX66 Y3/Y2 QUATTRO/Y2 TW IN

MODULO MOTORIZZATO STOZZATORE CORSA 50mm H=66mm

Slotting driven tool 50mm stroke H=66mm

Keilnutenstossmaschine 50mm Hub H=66mm

Subject to change without notice.

M.T. srl

Via Casino Albini 480
 Tel. 0541/956034-957884
 Fax 0541/956341
 47842 S. GIOVANNI IN M. (RN)
 e-mail: mtma@mtmarchetti.com
 http://www.mtmarchetti.com

PRODUZIONE MODULI ROTANTI



PAGINA CMZ360-3-00

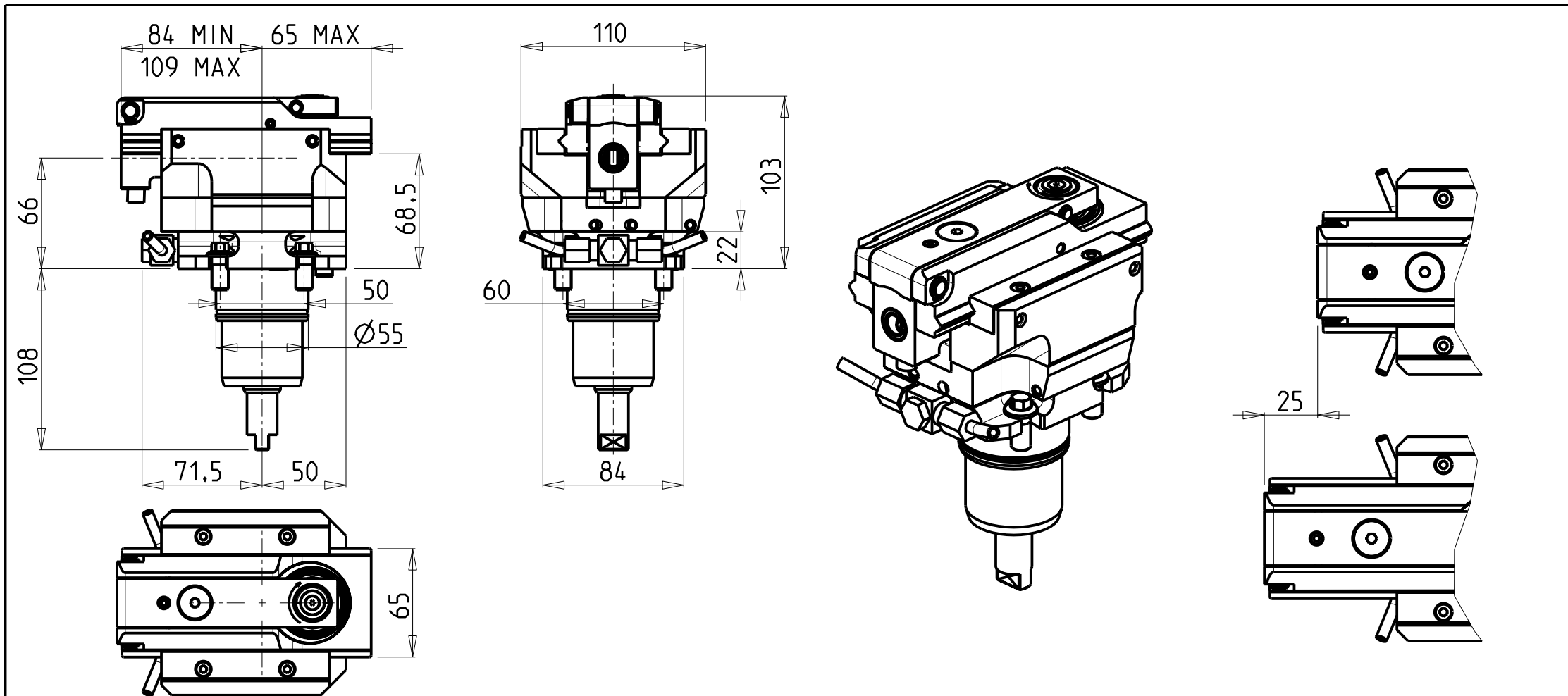

PER UTENSILI STOZZATORI VEDI PAG. TBL400-1-00
 FOR DRIVEN SLOTTING TOOL CUTTING-TOOLS SEE PAGE TBL400-1-00
 FÜR NUTENSTOSS-WERKZEUG SCHNEIDWERKZEUGE SIEHE SEITE TBL400-1-00

Cod. MT	I	RPM MAX	Reversibile lato mandrino/contromandrino Reversible sub/main spindle side Umkehrbare Spindel-seite/ Gegenspindel-seite	Lubr. esterna Ext. coolant Aussenkuehlung
NKM0910200	4:1	2400	X	X

CMZ
 MOD: TX52 Y3/Y2 QUATTRO/Y2 TWIN - TX66 Y3/Y2 QUATTRO/Y2 TWIN
 MODULO MOTORIZZATO STOZZATORE CORSA 25mm H=66mm
 Slotting driven tool 25mm stroke H=66mm
 Keilnutenstossmaschine 25mm Hub H=66mm

M.T. srl
 Via Casino Albini 480
 Tel. 0541/956034-957884
 Fax 0541/956341
 47842 S. GIOVANNI IN M. (RN)
 e-mail: mtma@mtmarchetti.com
 http://www.mtmarchetti.com

PRODUZIONE MODULI ROTANTI

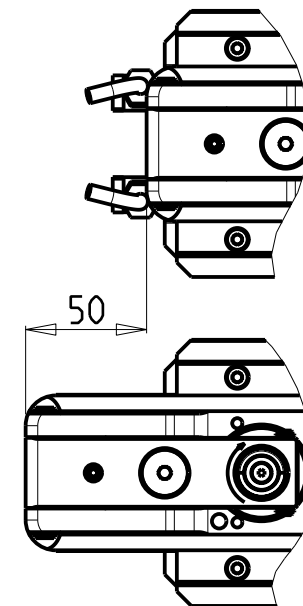
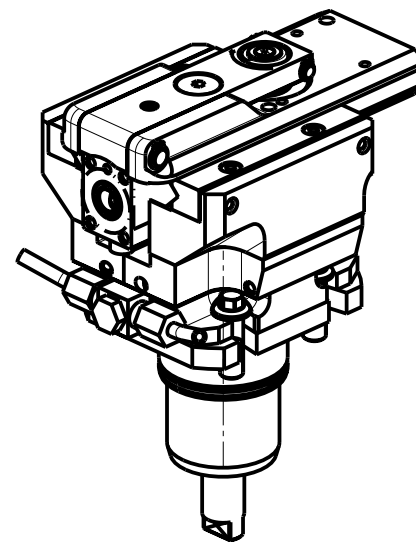
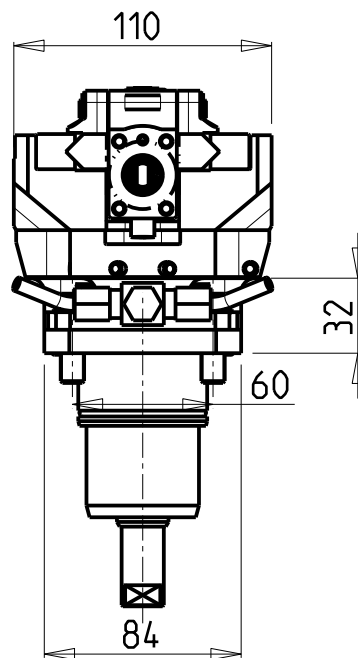
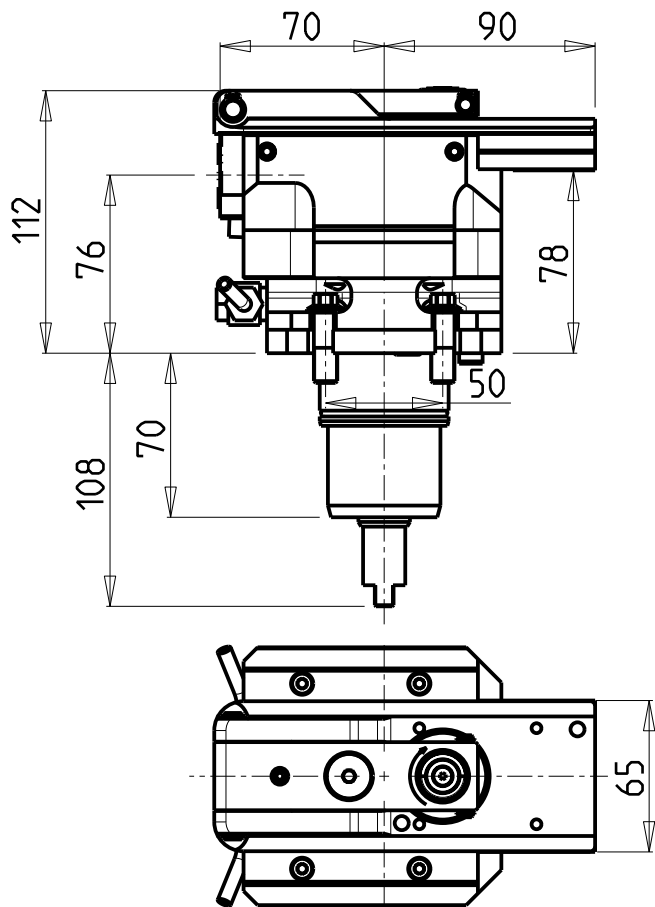
 PAGINA CMZ360-3-01



ATTENZIONE - ATTENTION - ACHTUNG

- VERIFICARE LE MISURE DI INGOMBRO PER POSSIBILE INTERFERENZA SU ALCUNI MODELLI DI MACCHINE
- Please check the overall sizes for possible interferences on some machine models
- Bitte überprüfen sie das ausmass um mögliche interferenzen auf einigen maschinen modellen zu vermeiden

PER UTENSILI STOZZATORI VEDI PAG. TBL400-1-00
 FOR DRIVEN SLOTTING TOOL CUTTING-TOOLS SEE PAGE TBL400-1-00
 FÜR NUTENSTOSS-WERKZEUG SCHNEIDWERKZEUGE SIEHE SEITE TBL400-1-00

Cod. MT	I	RPM MAX	Reversibile lato mandrino/contromandrino Reversible sub/main spindle side Umkehrbare Spindelseite/ Gegenspindelseite	Lubr. esterna Ext. coolant Aussenkuehlung
NKM0920100	4:1	2000	X	X

CMZ

MOD: TX52 Y3/Y2 QUATTRO/Y2 TW IN - TX66 Y3/Y2 QUATTRO/Y2 TW IN

MODULO MOTORIZZATO STOZZATORE CORSA 50mm H=76mm

Slotting driven tool 50mm stroke H=76mm

Keilnutenstossmaschine 50mm Hub H=76mm

Subject to change without notice.

M.T. srl

Via Casino Albini 480
 Tel. 0541/956034-957884
 Fax 0541/956341
 47842 S. GIOVANNI IN M. (RN)
 e-mail: mtma@tmarchetti.com
 http://www.tmmarchetti.com

PRODUZIONE MODULI ROTANTI



PAGINA CMZ360-3-10

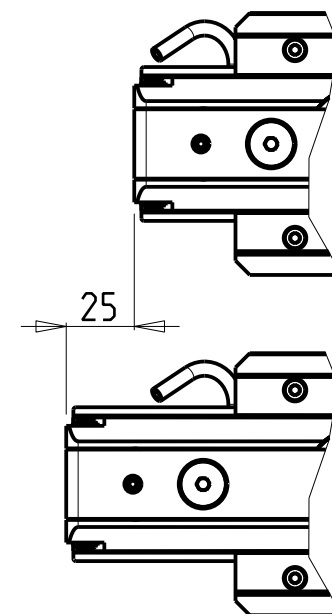
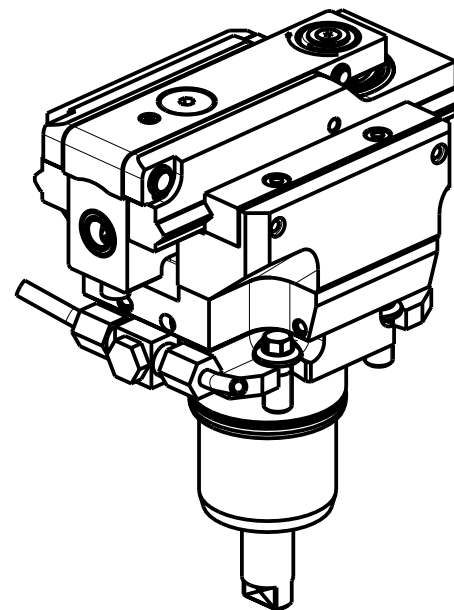
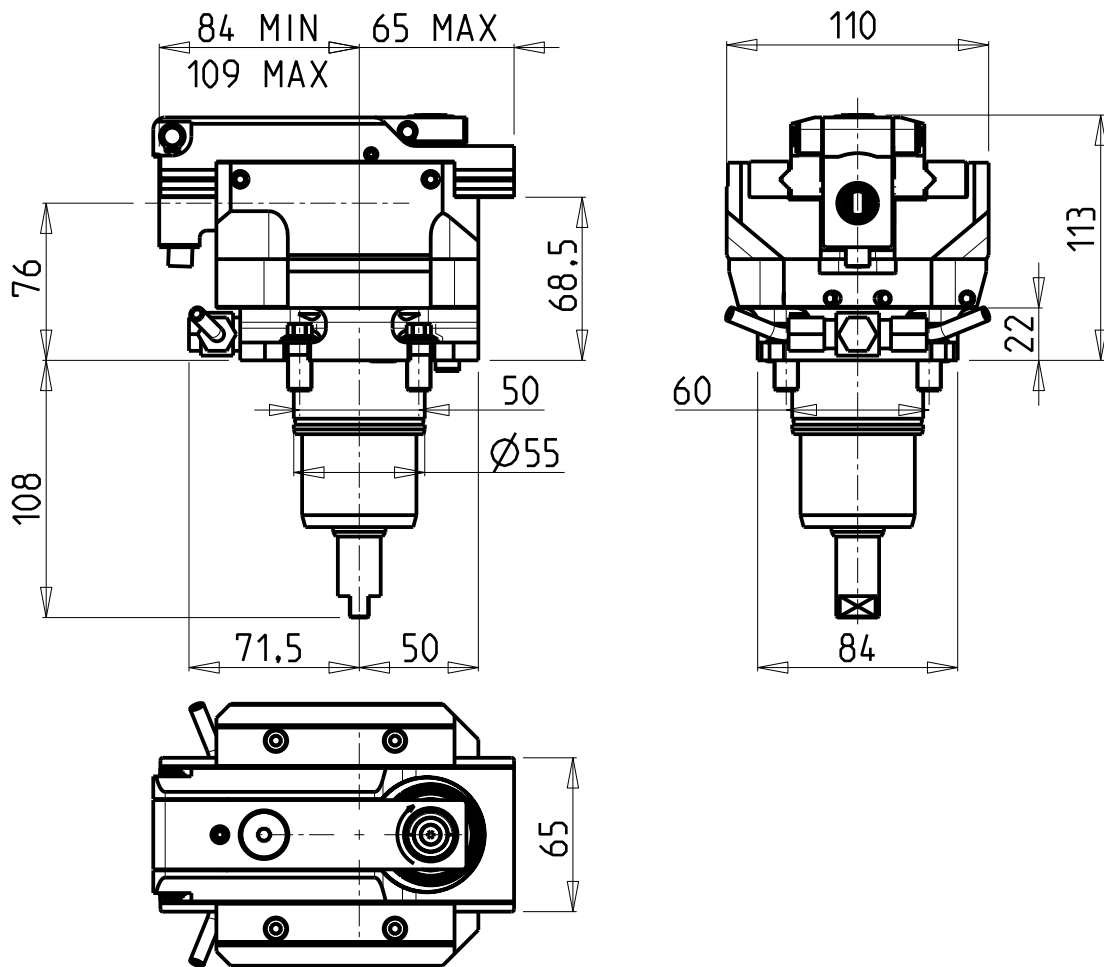

ATTENZIONE - ATTENTION - ACHTUNG

- VERIFICARE LE MISURE DI INGOMBRO PER POSSIBILE INTERFERENZA SU ALCUNI MODELLI DI MACCHINE
- Please check the overall sizes for possible interferences on some machine models
- Bitte überprüfen sie das ausmass um mögliche interferenzen auf einigen maschinen modellen zu vermeiden

PER UTENSILI STOZZATORI VEDI PAG. TBL400-1-00
 FOR DRIVEN SLOTTING TOOL CUTTING-TOOLS SEE PAGE TBL400-1-00
 FÜR NUTENSTOSS-WERKZEUG SCHNEIDWERKZEUGE SIEHE SEITE TBL400-1-00

Cod. MT	I	RPM MAX	Reversibile lato mandrino/contromandrino Reversible sub/main spindle side Umkehrbare Spindel-seite/ Gegenspindel-seite	Lubr. esterna Ext. coolant Aussenkuehlung
NKM0920200	4:1	2400	X	X

CMZ

MOD: TX52 Y3/Y2 QUATTRO/Y2 TW IN - TX66 Y3/Y2 QUATTRO/Y2 TW IN

MODULO MOTORIZZATO STOZZATORE CORSA 25mm H=76mm

Slotting driven tool 25mm stroke H=76mm

Keilnutenstossmaschine 25mm Hub H=76mm

Subject to change without notice.

M.T. srl

Via Casino Albini 480
 Tel. 0541/956034-957884
 Fax 0541/956341
 47842 S. GIOVANNI IN M. (RN)
 e-mail: mtma@mtmarchetti.com
 http://www.mtmarchetti.com

PRODUZIONE MODULI ROTANTI



PAGINA CMZ360-3-11

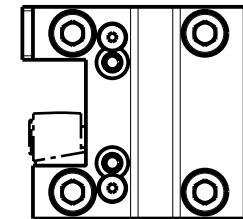
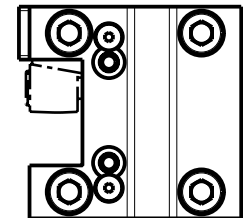
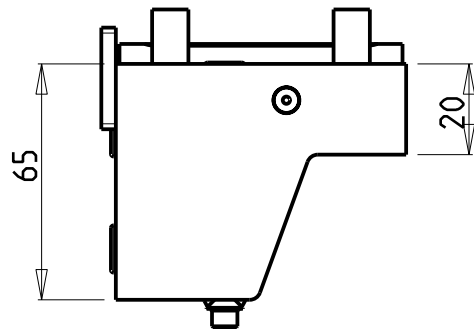
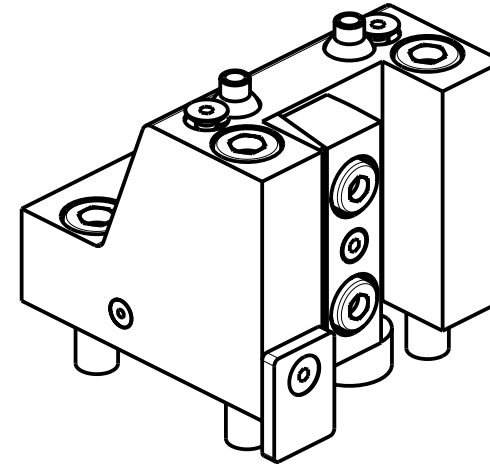
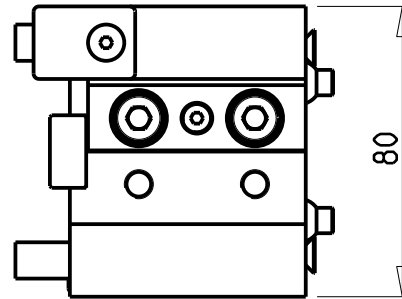
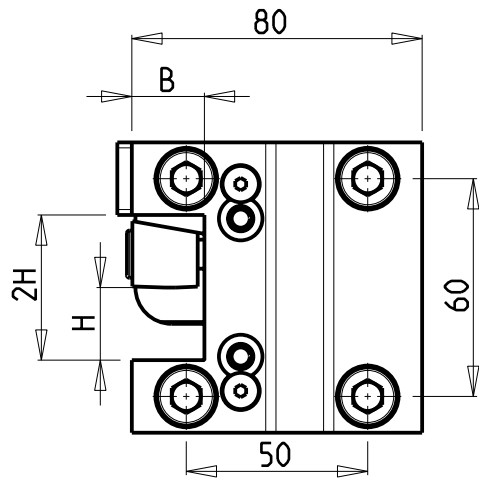

Cod. MT	N°Utensili N°Tools N°Werkzeuge	Reversibile lato mandrino/contromandrino Reversible sub/main spindle side Umkehrbare Spindel-seite/ Gegenspindel-seite	Misure Dimensions Masse	B	H
NKM0162000	1	X	mm	20	20
NKM0161905	1	X	Inch	3/4"	3/4"

CMZ
 MOD: TX52 Y3/Y2 QUATTRO/Y2 TW IN - TX66 Y3/Y2 QUATTRO/Y2 TW IN
 PORTAUTENSILE RADIALE SINGOLO QD=20mm / QD=3/4"
 Radial single static tool QD=20mm / QD=3/4"
 Radial Single-Werkzeughalter QD=20mm / QD=3/4"

M.T. srl
 Via Casino Albini 480
 Tel. 0541/956034-957884
 Fax 0541/956341
 47842 S. GIOVANNI IN M. (RN)
 e-mail: mtma@mtmarchetti.com
 http://www.mtmarchetti.com

PRODUZIONE MODULI ROTANTI



PAGINA CMZ420-3-00

Subject to change without notice.

10/2018

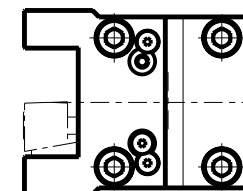
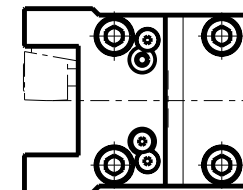
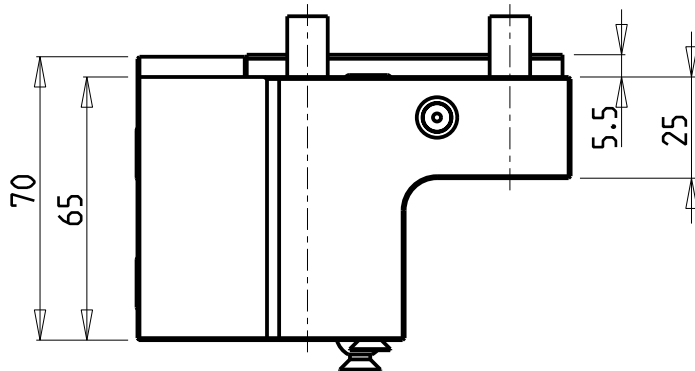
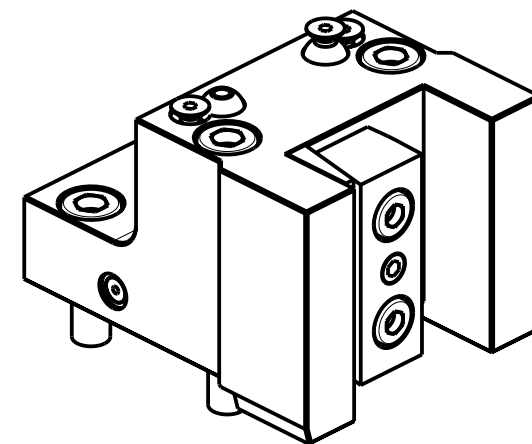
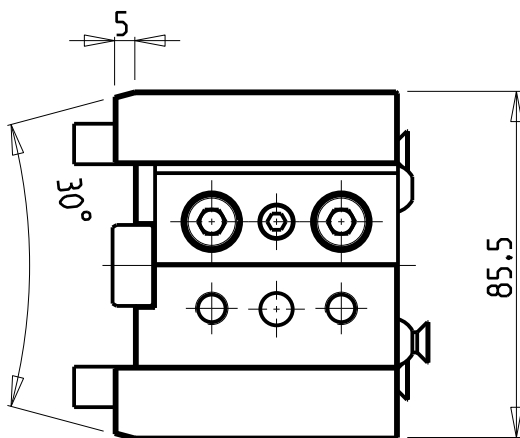
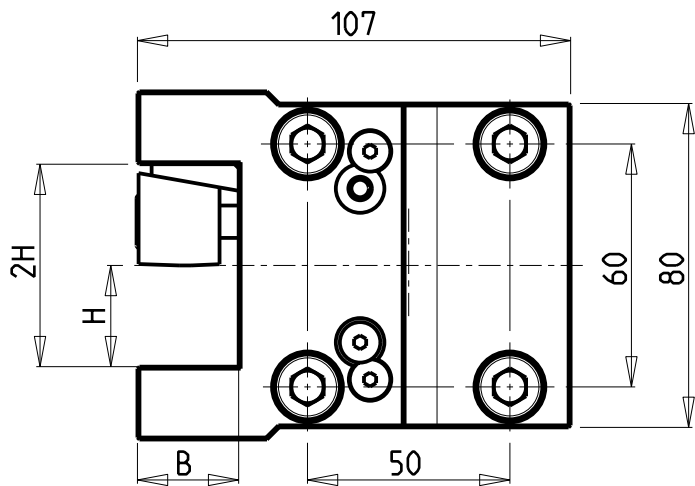

Cod. MT	Reversibile lato mandrino/contromandrino Reversible sub/main spindle side Umkehrbare Spindelsete/ Gegenspindelsete	Misure Dimensions Masse	B	H
NKM0162500	X	mm	25	25
NKM0162540	X	Inch	1"	1"

CMZ
 MOD: TX52 Y3/Y2 QUATTRO/Y2 TW IN - TX66 Y3/Y2 QUATTRO/Y2 TW IN
 PORTAUTENSILE RADIALE SINGOLO QD=25mm / QD=1"
 Radial single static tool QD=25mm / QD=1"
 Radial Single-Werkzeughalter QD=25mm / QD=1"

M.T. srl
 Via Casino Albini 480
 Tel. 0541/956034-957884
 Fax 0541/956341
 47842 S. GIOVANNI IN M. (RN)
 e-mail: mtma@mtmarchetti.com
 http://www.mtmarchetti.com

PRODUZIONE MODULI ROTANTI



PAGINA CMZ423-3-00

Subject to change without notice.

10/2018

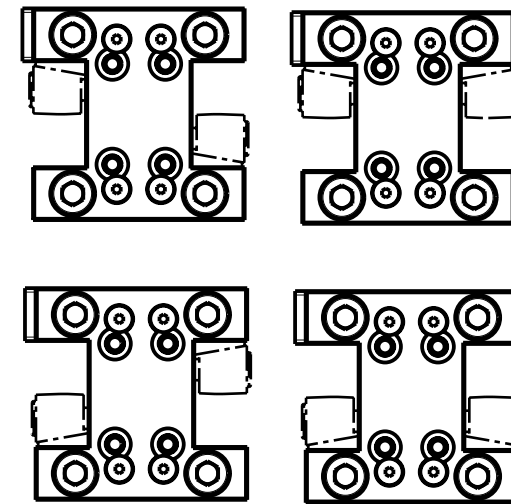
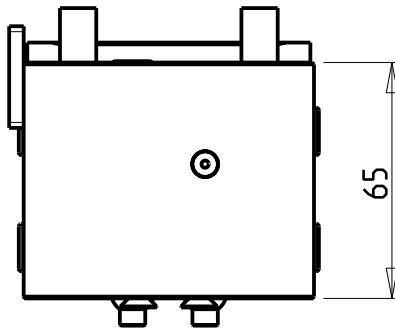
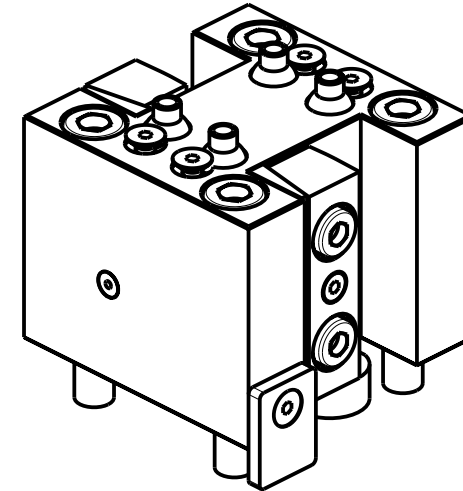
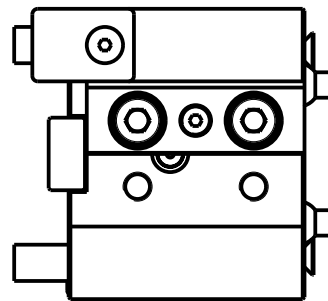
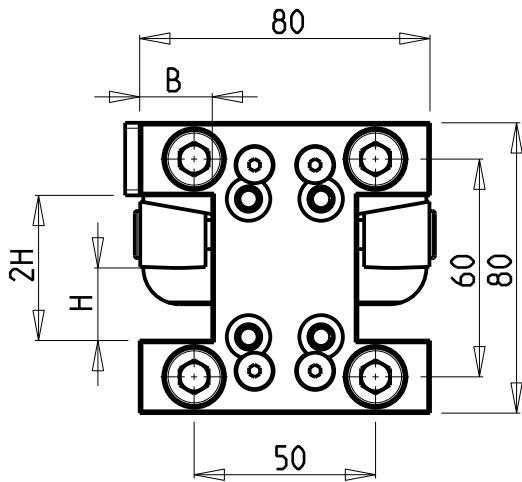

Cod. MT	N°Utensili N°Tools N°Werkzeuge	Reversibile lato mandrino/contromandrino Reversible sub/main spindle side Umkehrbare Spindel-seite/ Gegenspindel-seite	Misure Dimensions Masse	B	H
NKM0152000	2	X	mm	20	20
NKM0151905	2	X	Inch	3/4"	3/4"

CMZ
 MOD: TX52 Y3/Y2 QUATTRO/Y2 TWIN - TX66 Y3/Y2 QUATTRO/Y2 TWIN
 PORTAUTENSILE RADIALE DOPPIO QD=20mm / QD=3/4"
 Radial double static tool QD=20mm / QD=3/4"
 Radial Doppel-Werkzeughalter QD=20mm / QD=3/4"

M.T. srl
 Via Casino Albini 480
 Tel. 0541/956034-957884
 Fax 0541/956341
 47842 S. GIOVANNI IN M. (RN)
 e-mail: mtma@mtmarchetti.com
 http://www.mtmarchetti.com

PRODUZIONE MODULI ROTANTI

 PAGINA CMZ450-3-00

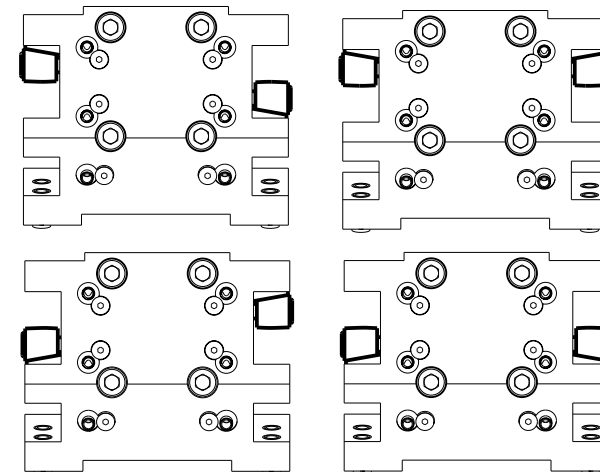
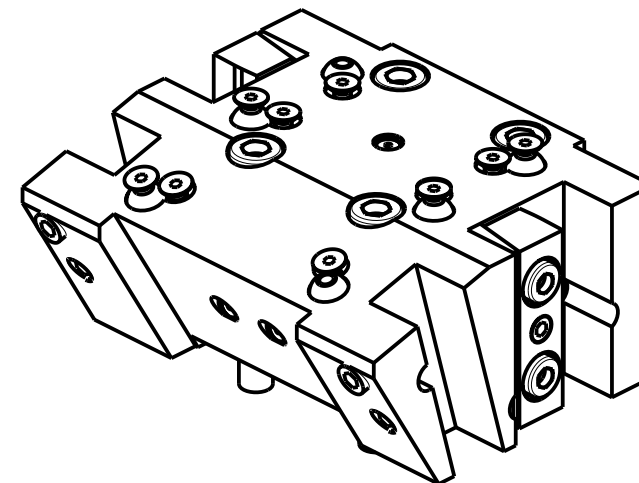
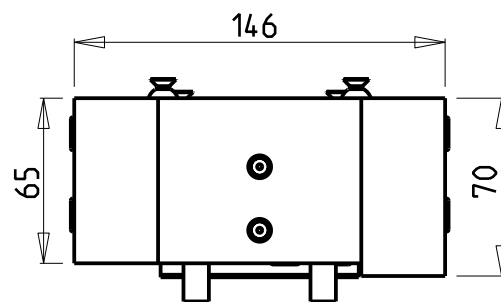
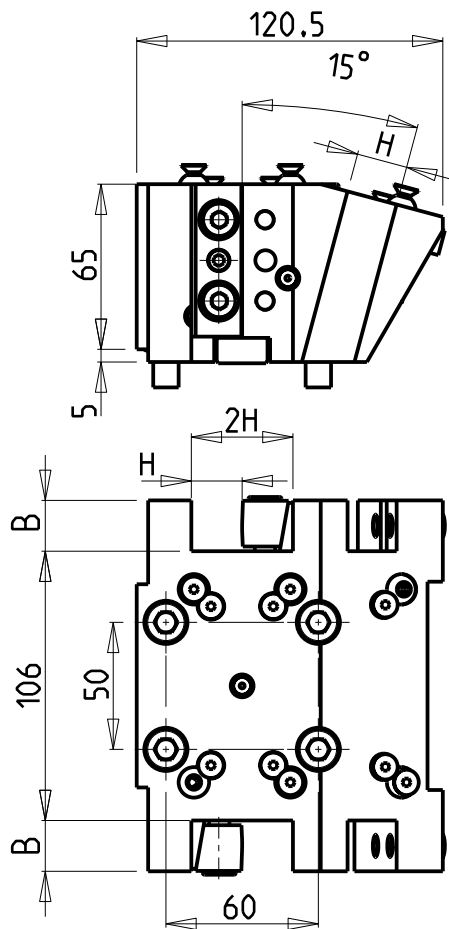
Subject to change without notice.



Cod. MT	N°Utensili N° Tools N° Werkzeuge	Reversibile lato mandrino/contromandrino Reversible sub/main spindle side Umkehrbare Spindel-seite/ Gegenspindel-seite	Misure Dimensions Masse	B	H
NKM0221000	4	X	mm	20	20
NKM0221905	4	X	Inch	3/4"	3/4"

CMZ
 MOD: TX52 Y3/Y2 QUATTRO/Y2 TWIN - TX66 Y3/Y2 QUATTRO/Y2 TWIN
 PORTAUTENSILE RADIALE MULTIPLIO QD=20mm / QD=3/4"
 Radial multiple static tool QD=20mm / QD=3/4"
 Radial Mehrfach-Werkzeughalter QD=20mm / QD=3/4"

M.T. srl
 Via Casino Albini 480
 Tel. 0541/956034-957884
 Fax 0541/956341
 47842 S. GIOVANNI IN M. (RN)
 e-mail: mtma@mtmarchetti.com
 http://www.mtmarchetti.com

PRODUZIONE MODULI ROTANTI



PAGINA CMZ470-3-00

Subject to change without notice.

10/2018

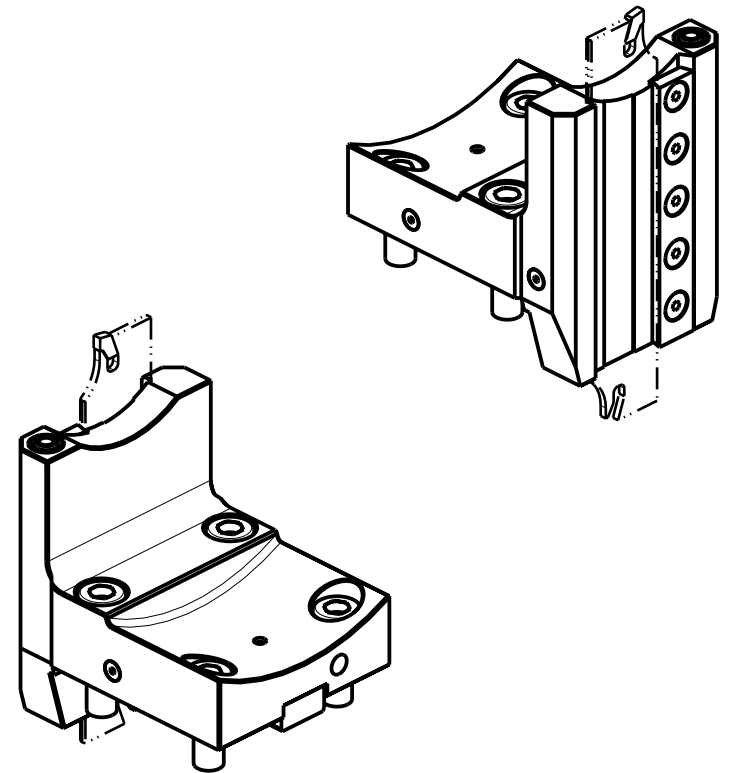
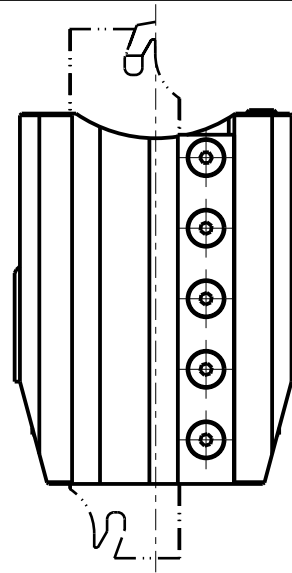
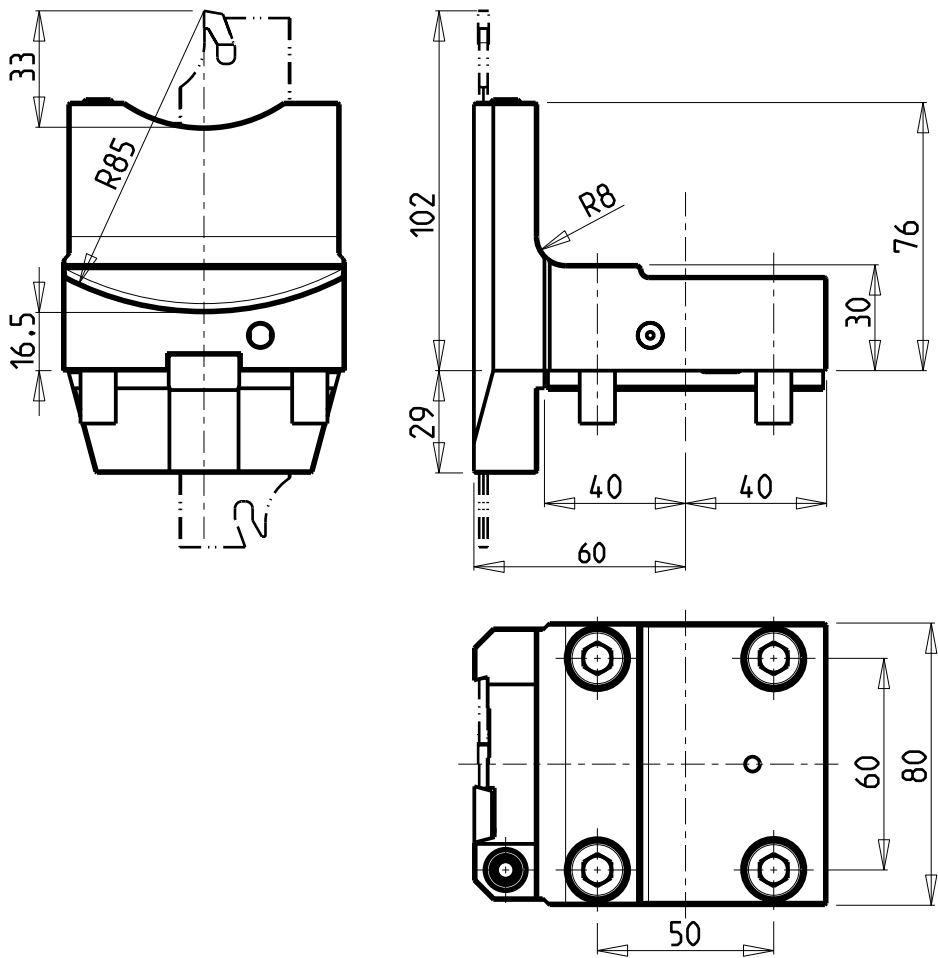

DOTAZIONI - SUPPLIED WITH - AUSSTATTUNG

- N°1 - LAMA - BLADE - KLINGE ISCAR H-32 Sp. 3/4mm (KENNAMETAL OPTIONAL)
- N°10 - INSERTI - INSERTS - EINLAGEN
- N°1 - CHIAVE A T PER MONTAGGIO INSERTI
- T-WRENCH FOR INSERT SET UP
- T-SCHLUESSEL FUER EINSATZSTUECK-MONTAGE

Cod. MT	N°Utensili N° Tools N° Werkzeuge	Reversibile lato mandrino/contromandrino Reversible sub/main spindle side Umkehrbare Spindelseite/ Gegenspindelseite
NKM0170132	1	X

CMZ
 MOD: TX52 Y3/Y2 QUATTRO/Y2 TWIN - TX66 Y3/Y2 QUATTRO/Y2 TWIN
 PORTAUTENSILE PER LAMA
 Radial blade holder
 Radial Abstechhalter

M.T. srl
 Via Casino Albini 480
 Tel. 0541/956034-957884
 Fax 0541/956341
 47842 S. GIOVANNI IN M. (RN)
 e-mail: mtma@mtmarchetti.com
 http://www.mtmarchetti.com

PRODUZIONE MODULI ROTANTI

 PAGINA CMZ510-3-00

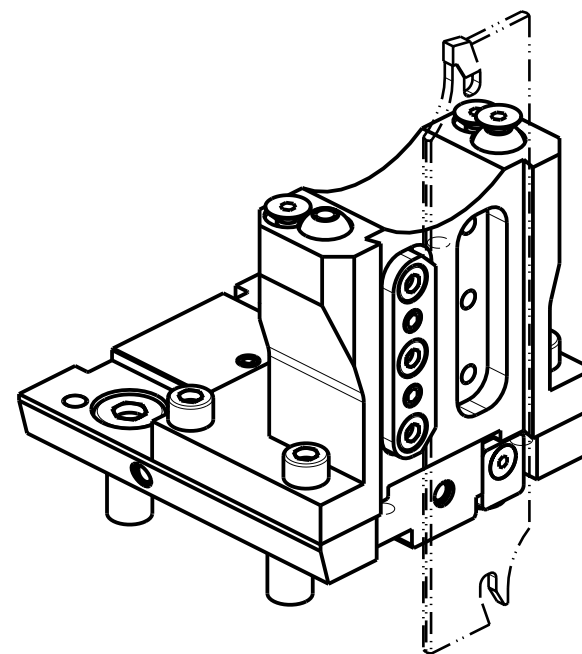
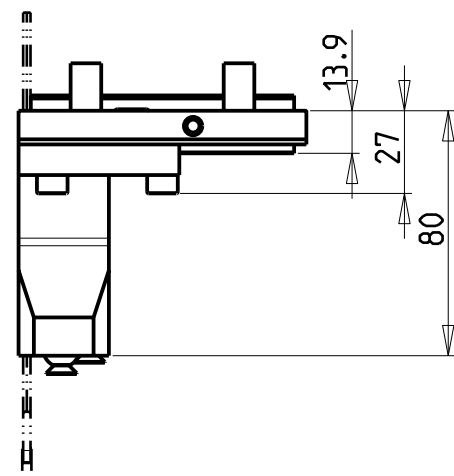
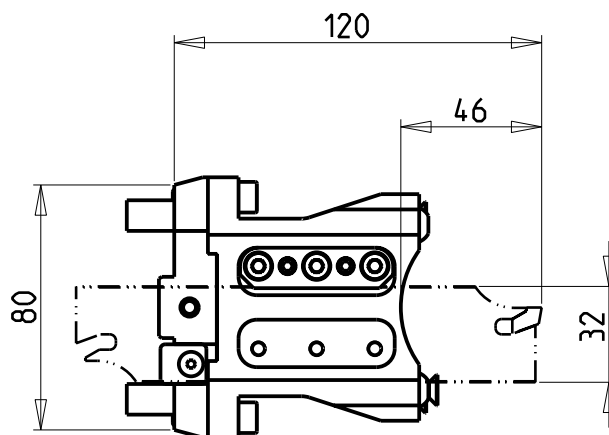
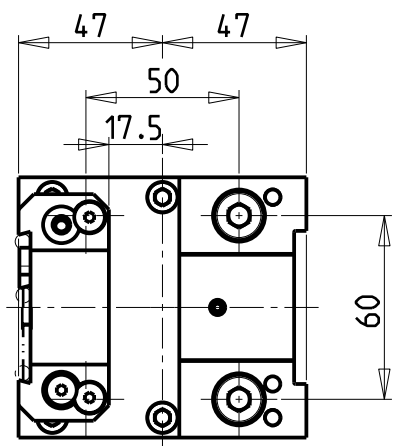
Subject to change without notice.



POSSIBILITA' DI LAVORO M3/M4
 OPTION OF M3/M4 WORKING
 ARBEITSMÖGLICHKEIT M3/M4

DOTAZIONI - SUPPLIED WITH - AUSSTATTUNG

N°1 - LAMA - BLADE - KLINGE ISCAR H=32 Sp. 3/4mm
 (KENNAMETAL OPTIONAL)

N°10 - INSERTI - INSERTS - EINLAGEN

N°1 - CHIAVE A T PER MONTAGGIO INSERTI
 - T-WRENCH FOR INSERT SET UP
 - T-SCHLUESSEL FUER EINSATZSTUECK-MONTAGE

Cod. MT	N°Utensili N°Tools N°Werkzeuge	Reversibile lato mandrino/contromandrino Reversible sub/main spindle side Umkehrbare Spindelseite/ Gegenspindelseite	Lubr.esterna Ext. coolant Aussenkuehlung
NKM1030132	1	X	X

CMZ
 MOD: TX52 Y3/Y2 QUATTRO/Y2 TWIN - TX66 Y3/Y2 QUATTRO/Y2 TWIN

PORTAUTENSILE RADIALE PER LAMA
 Radial blade holder
 Radial Abstechhalter

M.T. srl
 Via Casino Albini 480
 Tel. 0541/956034-957884
 Fax 0541/956341
 47842 S. GIOVANNI IN M. (RN)
 e-mail: mtma@mtmarchetti.com
 http://www.mtmarchetti.com

PRODUZIONE MODULI ROTANTI



PAGINA CMZ520-3-01

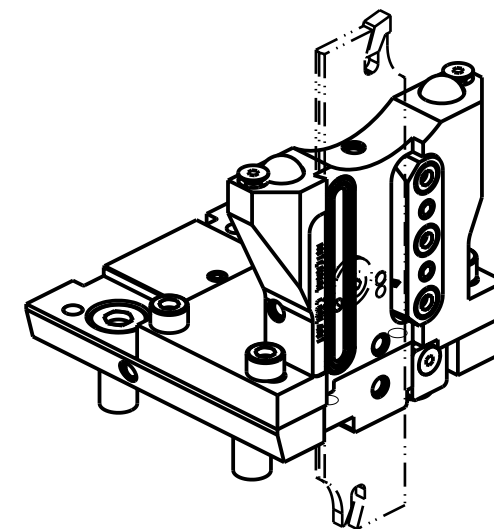
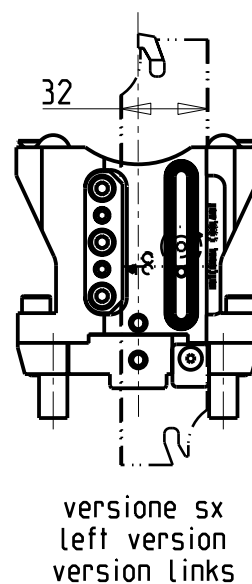
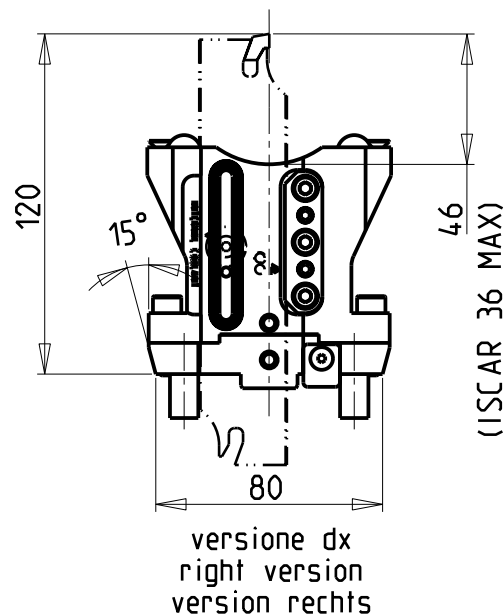
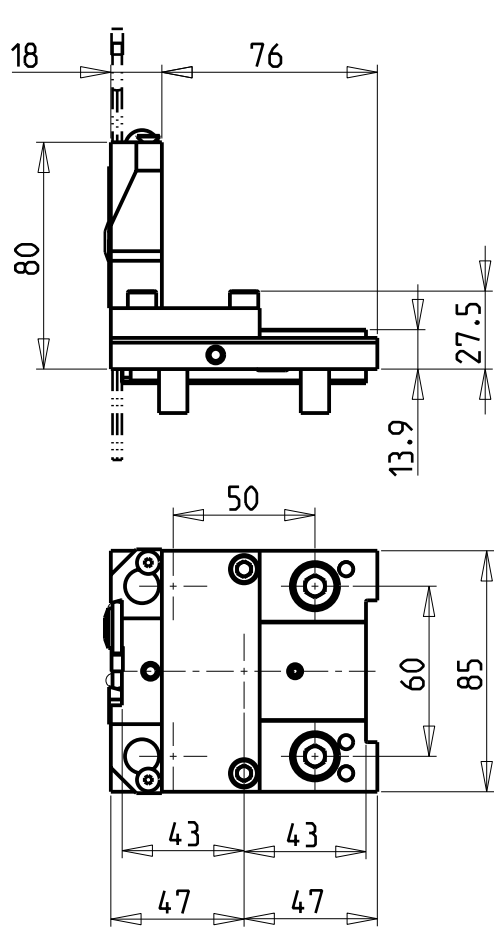

**KIT LAME NON INCLUSI (OPZIONALI)
BLADES NOT SUPPLIED WITH (OPTIONAL)
KLINGEN NICHT INBEGRIFFEN (OPTIONAL)**

- LAMA-BLADE-KLINGE SANDVIK H=32 sp.3 cod. QD_NN2G60C25A
+INSERTI-INSERTS-EINLAGEN cod. QD_NG_0300_0002_CM_1145 (10 pz.)
- LAMA-BLADE-KLINGE SANDVIK H=32 sp.4 cod. QD_NN2H60C25A
+INSERTI-INSERTS-EINLAGEN cod. QD_NH_0400_0002_CM_1145 (10 pz.)
- LAMA-BLADE-KLINGE ISCAR H=32 sp.3 cod. SGFH_32K_3
+INSERTI-INSERTS-EINLAGEN cod. 6011365 (10pz.)
- LAMA-BLADE-KLINGE ISCAR H=32 sp.4 cod. SGFH_32K_4
+INSERTI-INSERTS-EINLAGEN cod. 6011366 (10pz.)
- LAMA-BLADE-KLINGE WALTER H=32 sp.3 cod. G2042.32N-3T45SX-P
+INSERTI-INSERTS-EINLAGEN cod. SX-3E300N02-CE4 WSM33S (10pz.) + CHIAVE-KEY cod. FS1494
- LAMA-BLADE-KLINGE WALTER H=32 sp.4 cod. G2042.32N-4T50SX-P
+INSERTI-INSERTS-EINLAGEN cod. SX-4E400N02-CE4 WSM33S (10pz.) + CHIAVE-KEY cod. FS1494

Cod. MT		N°Utensili N°Tools N°Werkzeuge	Reversibile lato mandrino/contromandrino Reversible sub/main spindle side Umkehrbare Spindel-seite/ Gegenspindel-seite	Lubr.esterna Ext. coolant Aussenkuehlung	Lubr.interna Coolant through Innenkuehlung
versione dx right version version rechts	versione sx left version version links				
NKM1110132R	NKM1110132L	1	X	X	P=70bar

CMZ
MOD: TX52 Y3/Y2 QUATTRO/Y2 TWIN - TX66 Y3/Y2 QUATTRO/Y2 TWIN
PORTAUTENSILE RADIALE PER LAMA CON LUBRIFICAZIONE INTERNA
Radial blade holder with internal coolant
Radial Abstechhalter mit Innenkuehlung

M.T. srl
Via Casino Albini 480
Tel. 0541/956034-957884
Fax 0541/956341
47842 S. GIOVANNI IN M. (RN)
e-mail: mtma@mtmarchetti.com
http://www.mtmarchetti.com

PRODUZIONE MODULI ROTANTI



PAGINA CMZ520-3-05

Subject to change without notice.

10/2018

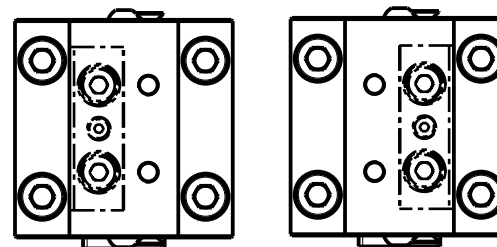
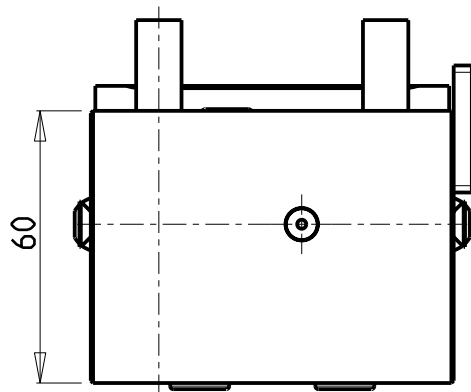
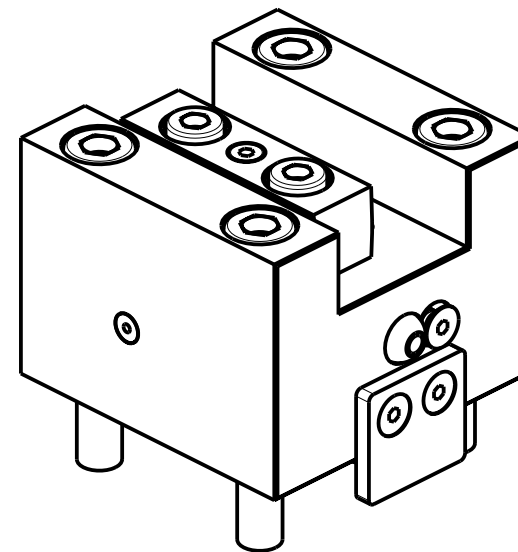
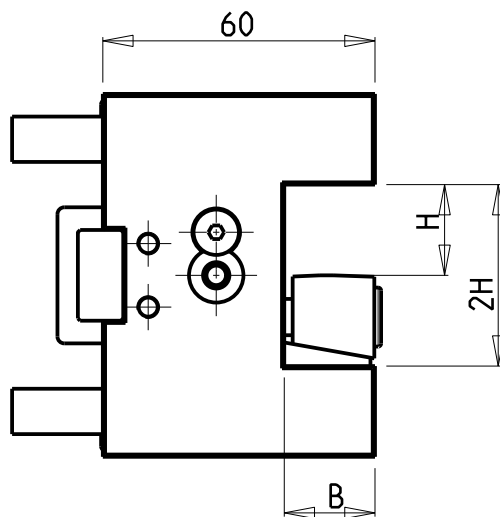
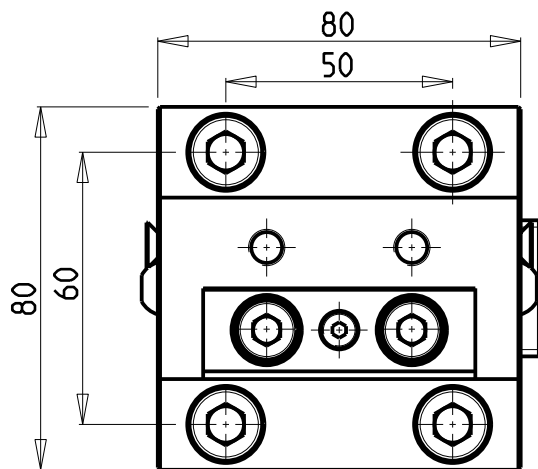

Cod. MT	N°Utensili N° Tools N° Werkzeuge	Reversibile lato mandrino/contromandrino Reversible sub/main spindle side Umkehrbare Spindel-seite/ Gegenspindel-seite	Misure Dimensions Masse	B	H
NKM0182000	1	X	mm	20	20
NKM0181905	1	X	Inch	3/4"	3/4"

CMZ
 MOD: TX52 Y3/Y2 QUATTRO/Y2 TW IN - TX66 Y3/Y2 QUATTRO/Y2 TW IN
 PORTAUTENSILE ASSIALE SINGOLO QD=20mm / QD=3/4"
 Axial single static tool QD=20mm / QD=3/4"
 Axial Single-Werkzeughalter QD=20mm / QD=3/4"

M.T. srl
 Via Casino Albini 480
 Tel. 0541/956034-957884
 Fax 0541/956341
 47842 S. GIOVANNI IN M. (RN)
 e-mail: mtma@mtmarchetti.com
 http://www.mtmarchetti.com

PRODUZIONE MODULI ROTANTI



PAGINA CMZ550-3-00

Subject to change without notice.

10/2018

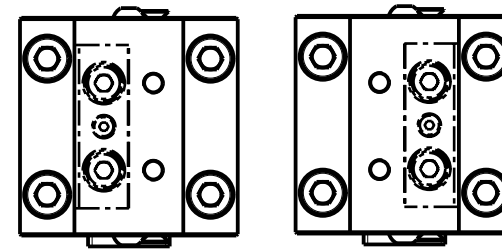
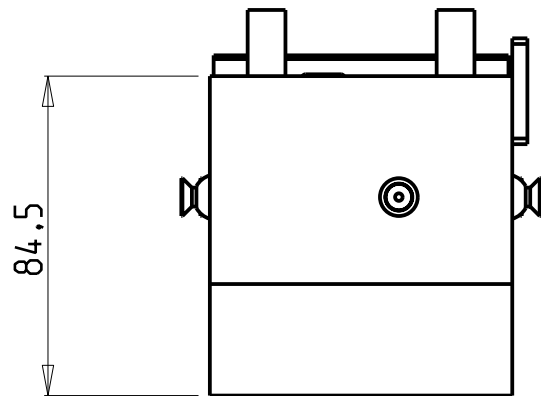
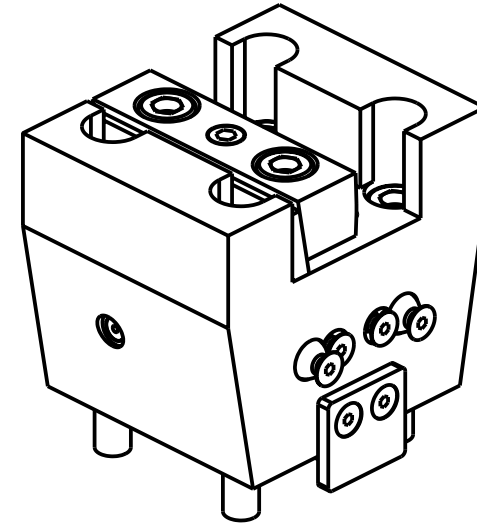
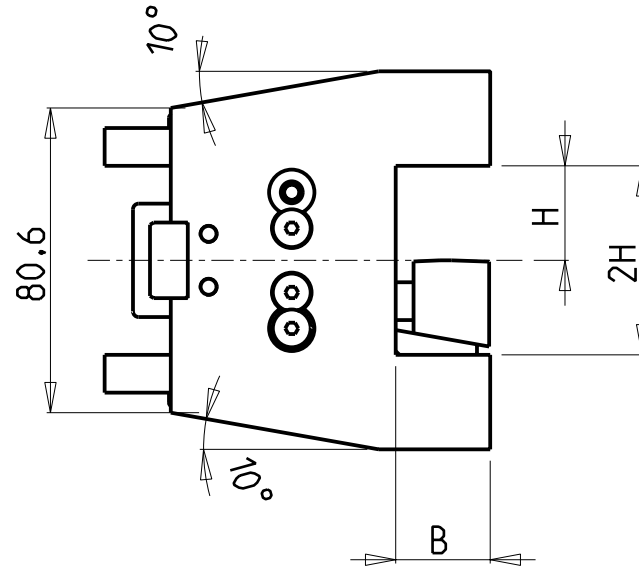
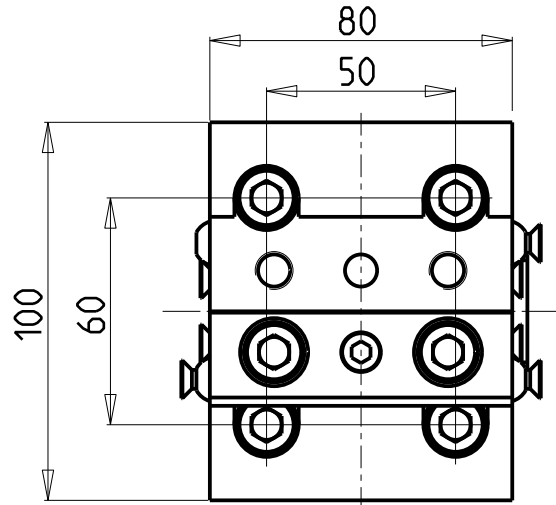

Cod. MT	N°Utensili N° Tools N°Werkzeuge	Reversibile lato mandrino/contromandrino Reversible sub/main spindle side Umkehrbare Spindelseite/ Gegenspindelseite	Lubrificazione est. Ext. coolant Aussenkuehlung	Misure Dimensions Masse	B	H
NKM0182500	1	X	X	mm	25	25

CMZ

MOD: TX52 Y3/Y2 QUATTRO/Y2 TW IN - TX66 Y3/Y2 QUATTRO/Y2 TW IN

PORTAUTENSILE ASSIALE SINGOLO QD=25mm

Axial single static tool QD=25mm

Axial Single-Werkzeughalter QD=25mm

Subject to change without notice.

M.T. srl

Via Casino Albini 480
Tel. 0541/956034-957884
Fax 0541/956341
47842 S. GIOVANNI IN M. (RN)
e-mail: mtma@mtmarchetti.com
http://www.mtmarchetti.com

PRODUZIONE MODULI ROTANTI



PAGINA CMZ552-3-00

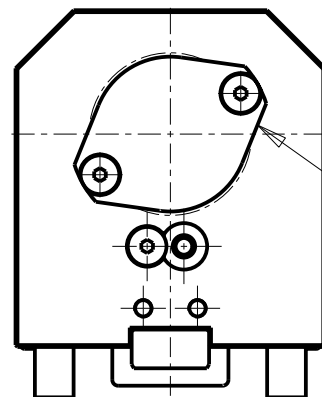
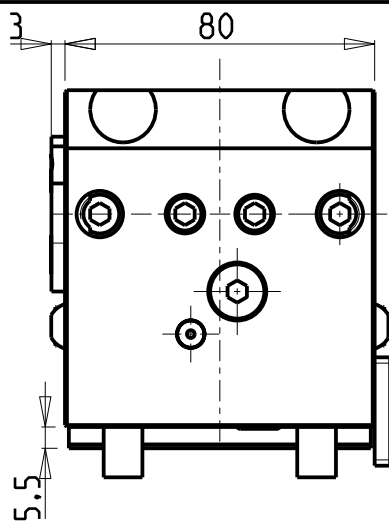
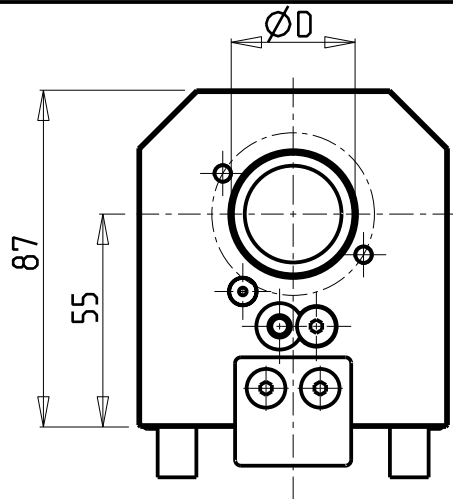

KIT ADDUZIONE INTERNA (OPZIONALE)
 KIT FOR INTERNAL COOLANT (OPTIONAL)
 KIT FUER INTERNE KUEHLMITTELZUFUHR (OPTIONAL)
 Ø32-Ø1 1/4" cod. KIT1000001

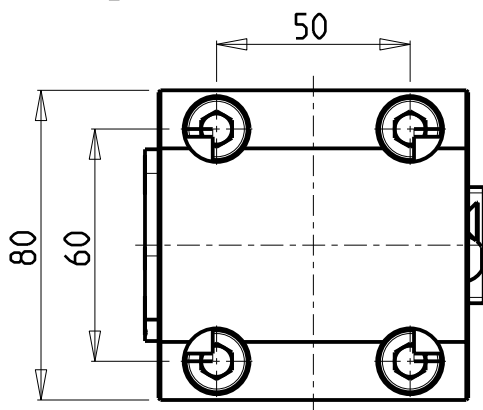

PER BOCCOLE DI RIDUZIONE VEDI PAG. TBL150-1-00
 FOR REDUCING BUSHINGS SEE PAGE TBL150-1-00
 FÜR REDUZIERBUCHSE SIEHE SEITE TBL150-1-00

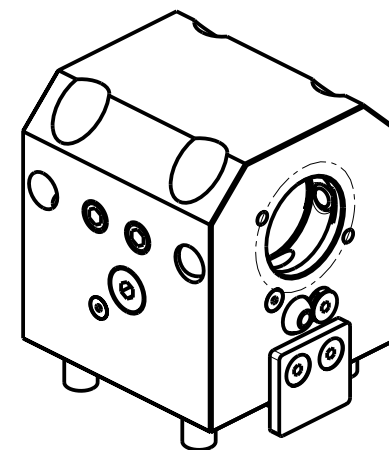

Cod. MT	N°Utensili N°Tools N°Werkzeuge	Reversibile lato mandrino/contromandrino Reversible sub/main spindle side Umkehrbare Spindel-seite/ Gegenspindel-seite	Lubrificazione int. opzionale Coolant through optional Innenkuehlung Optional	Lubrificazione est. Ext. coolant Aussenkuehlung	Misure Dimensions Masse	D
NKM0113220	1	X	X	X	mm	32
NKM0113230	1	X	X	X	Inch	1 1/4"

CMZ

MOD: TX52 Y3/Y2 QUATTRO/Y2 TWIN - TX66 Y3/Y2 QUATTRO/Y2 TWIN

PORTAUTENSILE ASSIALE PER BARENO Ø32mm / Ø1 1/4" H=55mm

Axial single boring bar holder Ø32mm / Ø1 1/4" H=55mm

Axial Bohrhälter Ø32mm / Ø1 1/4" H=55mm

Subject to change without notice.

M.T. srl

Via Casino Albini 480

Tel. 0541/956034-957884

Fax 0541/956341

47842 S. GIOVANNI IN M. (RN)

e-mail: mtma@mtmarchetti.com

http://www.mtmarchetti.com

PRODUZIONE MODULI ROTANTI



PAGINA CMZ650-3-10

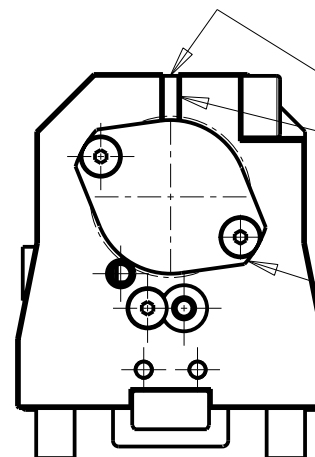
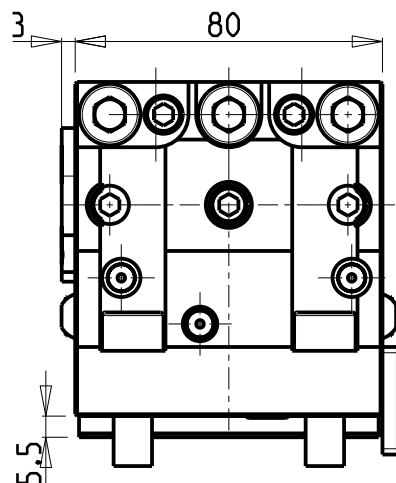
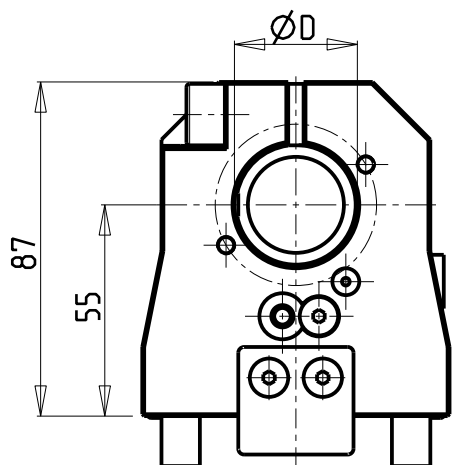

SOLO GUARNIZIONE (OPZIONALE)
 ONLY SEAL (OPTIONAL)
 NUR DICHTUNG (OPTIONAL)
 cod. NKM0110009

KIT ADDUZIONE INTERNA (OPZIONALE)
 KIT FOR INTERNAL COOLANT (OPTIONAL)
 KIT FUER INTERNE KUEHLMITTELZUFUHR (OPTIONAL)
 Ø32-Ø1 1/4" cod. KIT1004001

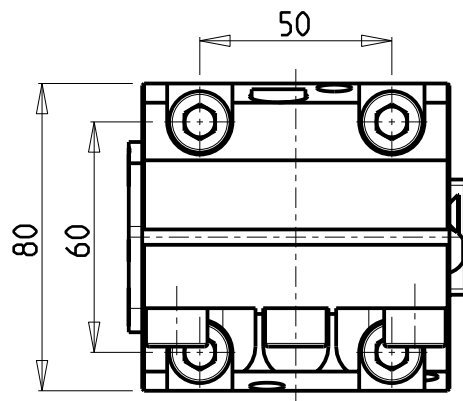

PER BOCCOLE DI RIDUZIONE VEDI PAG. TBL150-1-00
 FOR REDUCING BUSHINGS SEE PAGE TBL150-1-00
 FÜR REDUZIERBUCHSE SIEHE SEITE TBL150-1-00

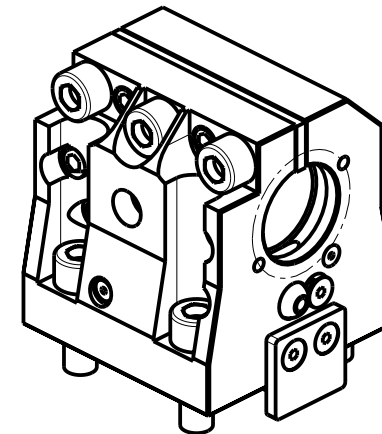

Cod. MT	N°Utensili N°Tools N°Werkzeuge	Reversibile lato mandrino/contromandrino Reversible sub/main spindle side Umkehrbare Spindel-seite/ Gegenspindel-seite	Lubrificazione int. opzionale Coolant through optional Innenkuehlung Optional	Lubrificazione est. Ext. coolant Aussenkuehlung	Misure Dimensions Masse	D
NKM0113221	1	X	X	X	mm	32
NKM0113231	1	X	X	X	Inch	1 1/4"

CMZ
 MOD: TX52 Y3/Y2 QUATTRO/Y2 TWIN - TX66 Y3/Y2 QUATTRO/Y2 TWIN
 PORTAUTENSILE ASSIALE SPECIALE PER BARENO Ø32mm / Ø1 1/4" H=55mm
 Axial special boring bar holder Ø32mm / Ø1 1/4" H=55mm
 Axial spezial Bohrhälter Ø32mm / Ø1 1/4" H=55mm

M.T. srl
 Via Casino Albini 480
 Tel. 0541/956034-957884
 Fax 0541/956341
 47842 S. GIOVANNI IN M. (RN)
 e-mail: mtma@mtmarchetti.com
 http://www.mtmarchetti.com

PRODUZIONE MODULI ROTANTI



PAGINA CMZ650-3-20

Subject to change without notice.

10/2018

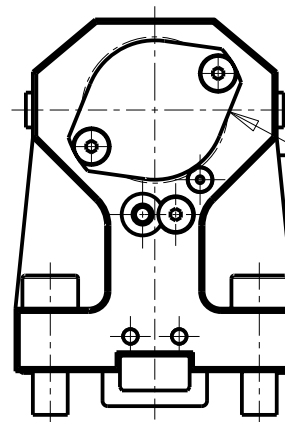
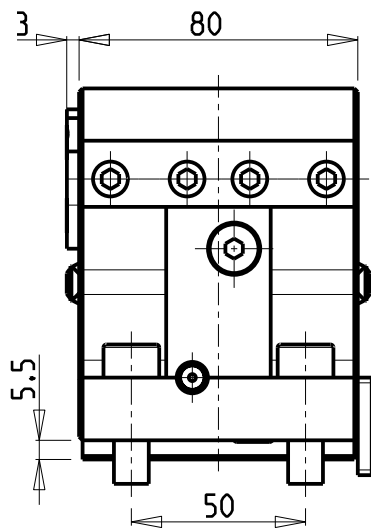
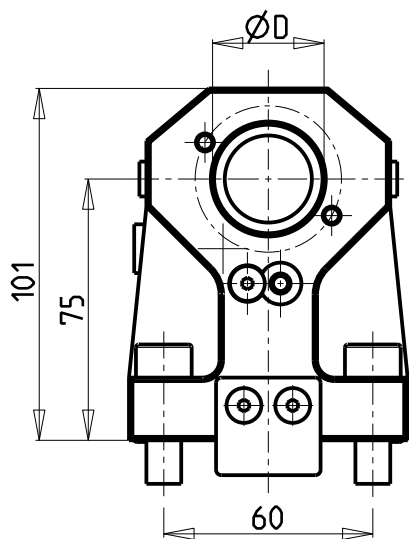

KIT ADDUZIONE INTERNA (OPZIONALE)
 KIT FOR INTERNAL COOLANT (OPTIONAL)
 KIT FUER INTERNE KUEHLMITTELZUFUHR (OPTIONAL)
 Ø32-Ø1 1/4" cod. KIT1000001
 Ø40 cod. KIT1000018

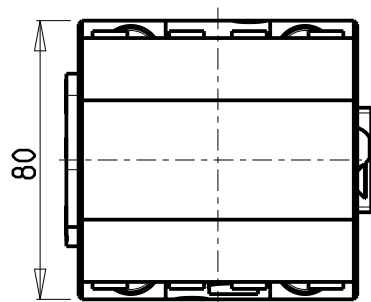

PER BOCCOLE DI RIDUZIONE VEDI PAG. TBL150-1-00
 FOR REDUCING BUSHINGS SEE PAGE TBL150-1-00
 FÜR REDUZIERBUCHSE SIEHE SEITE TBL150-1-00

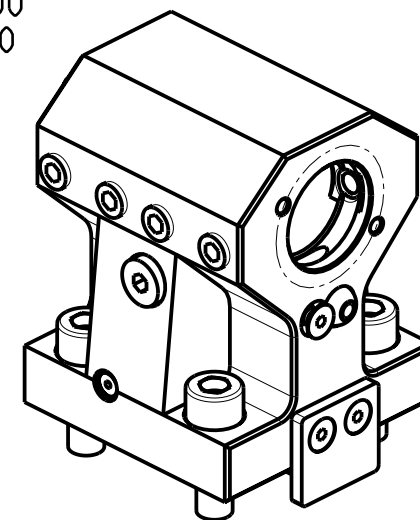

Cod. MT	N°Utensili N°Tools N°Werkzeuge	Reversibile lato mandrino/contromandrino Reversible sub/main spindle side Umkehrbare Spindel-seite/ Gegenspindel-seite	Lubrificazione int. opzionale Coolant through optional Innenkuehlung Optional	Lubrificazione est. Ext. coolant Aussenkuehlung	Misure Dimensions Masse	D
NKM0114000	1	X	X	X	mm	40
NKM0113200	1	X	X	X	mm	32
NKM0113210	1	X	X	X	Inch	1 1/4"

CMZ

MOD: TX52 Y3/Y2 QUATTRO/Y2 TWIN - TX66 Y3/Y2 QUATTRO/Y2 TWIN

PORTAUTENSILE ASSIALE PER BARENO Ø40mm / Ø32mm / Ø1 1/4" H=75mm

Axial single boring bar holder Ø40mm / Ø32mm / Ø1 1/4" H=75mm

Axial Bohrhälter Ø40mm / Ø32mm / Ø1 1/4" H=75mm

Subject to change without notice.

M.T. srl

Via Casino Albini 480
 Tel. 0541/956034-957884
 Fax 0541/956341

47842 S. GIOVANNI IN M. (RN)
 e-mail: mtma@mtmarchetti.com
 http://www.mtmarchetti.com

PRODUZIONE MODULI ROTANTI



PAGINA CMZ660-3-10

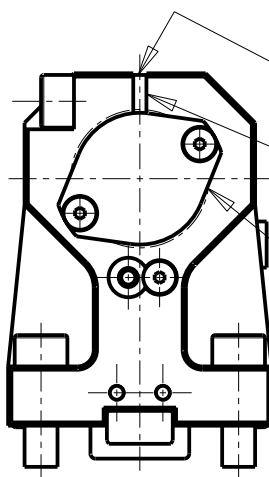
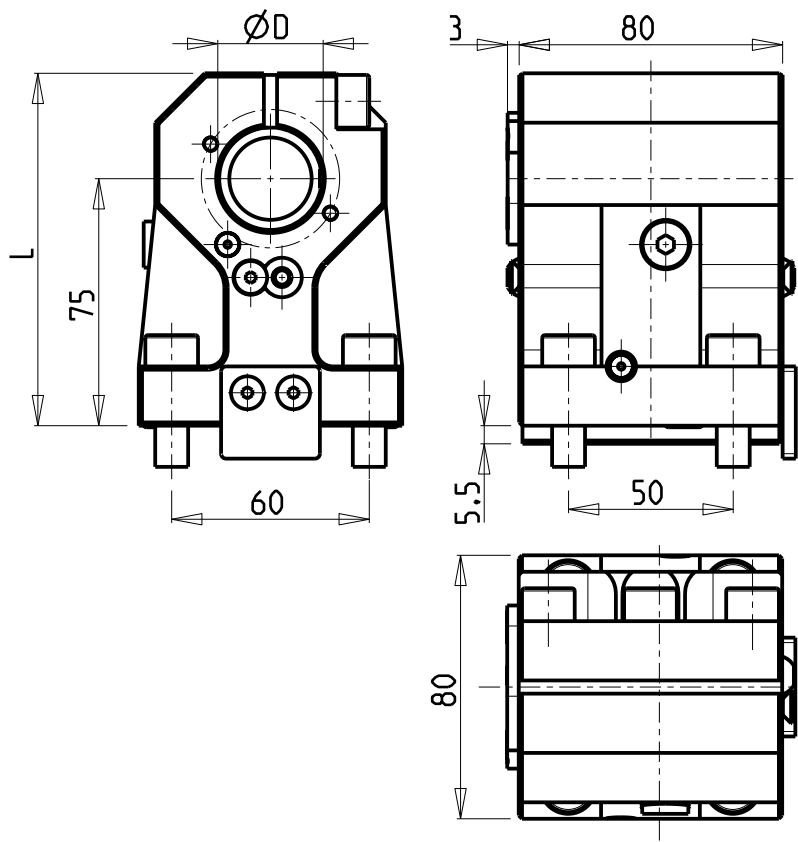

SOLO GUARNIZIONE (OPZIONALE)
 ONLY SEAL (OPTIONAL)
 NUR DICHTUNG (OPTIONAL)
 cod. NKM0110009

KIT ADDUZIONE INTERNA (OPZIONALE)
 KIT FOR INTERNAL COOLANT (OPTIONAL)
 KIT FUER INTERNE KUEHLMITTELZUFUHR (OPTIONAL)
 Ø32-Ø1 1/4" cod. KIT1004001
 Ø40 cod. KIT1004018
 Ø1 1/2" cod. KIT1004021

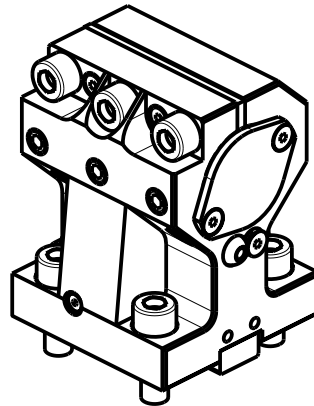

PER BOCCOLE DI RIDUZIONE VEDI PAG. TBL150-1-00
 FOR REDUCING BUSHINGS SEE PAGE TBL150-1-00
 FÜR REDUZIERBUCHSE SIEHE SEITE TBL150-1-00

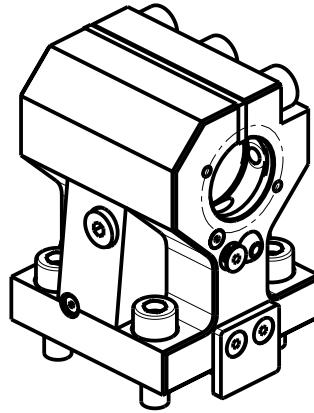

Cod. MT	Reversibile lato mandrino/contromandrino Reversible sub/main spindle side Umkehrbare Spindel-seite/ Gegenspindel-seite	Lubrificazione int. opzionale Coolant through optional Innenkuehlung Optional	Lubrificazione est. Ext. coolant Aussenkuehlung	D	L
NKM0114010	X	X	X	40	111
NKM0114030	X	X	X	1 1/2"	111
NKM0113201	X	X	X	32	107
NKM0113211	X	X	X	1 1/4"	107

CMZ
 MOD: TX52 Y3/Y2 QUATTRO/Y2 TWIN - TX66 Y3/Y2 QUATTRO/Y2 TWIN

PORTAUTENSILE ASSIALE PER BARENO Ø40mm / Ø1 1/2" / Ø32mm / Ø1 1/4" H=75mm
 Axial single boring bar holder Ø40mm / Ø1 1/2" / Ø32mm / Ø1 1/4" H=75mm
 Axial Bohrhälter Ø40mm / Ø1 1/2" / Ø32mm / Ø1 1/4" H=75mm

Subject to change without notice.

M.T. srl
 Via Casino Albini 480
 Tel. 0541/956034-957884
 Fax 0541/956341
 47842 S. GIOVANNI IN M. (RN)
 e-mail: mtma@mtmarchetti.com
 http://www.mtmarchetti.com

PRODUZIONE MODULI ROTANTI



PAGINA CMZ660-3-20

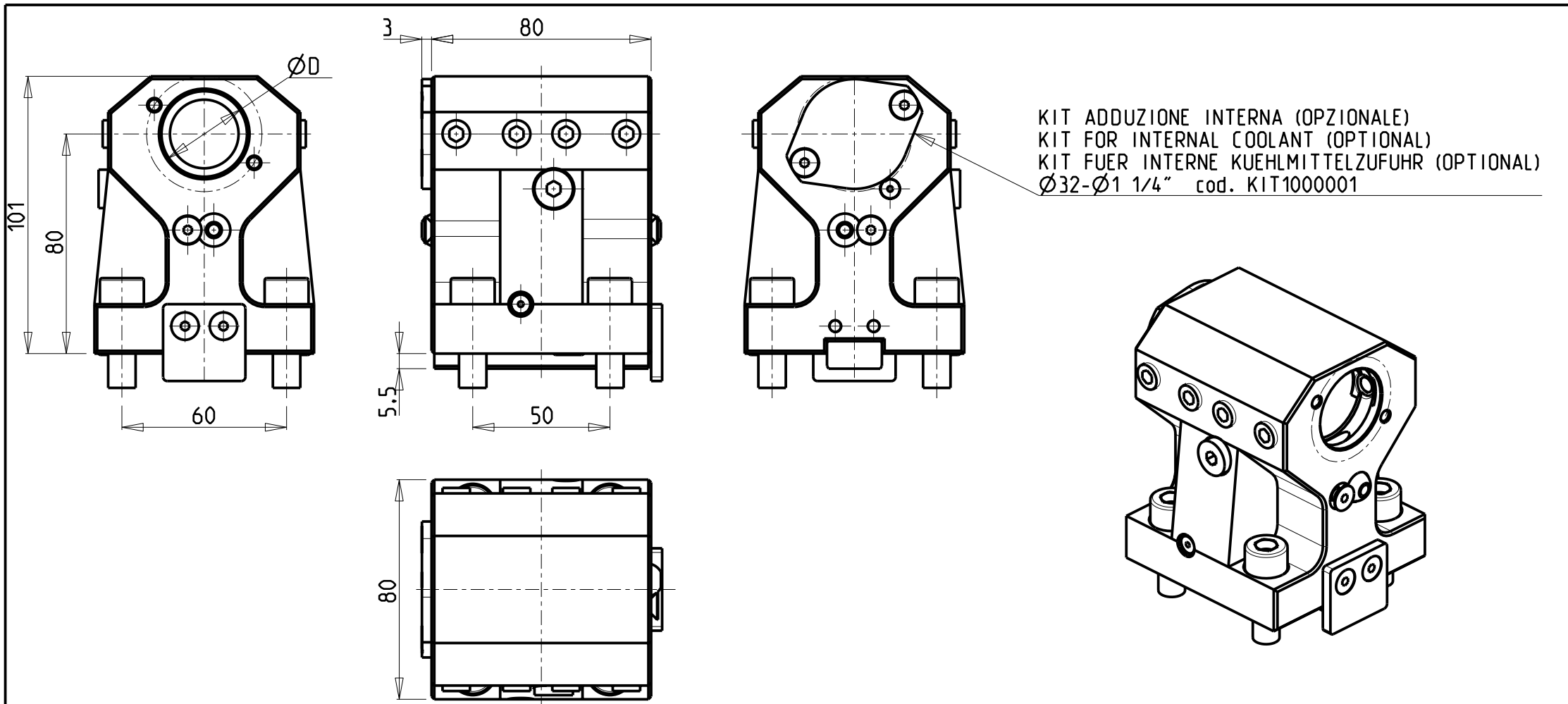

KIT ADDUZIONE INTERNA (OPZIONALE)
 KIT FOR INTERNAL COOLANT (OPTIONAL)
 KIT FUER INTERNE KUEHLMITTELZUFUHR (OPTIONAL)
 Ø32-Ø1 1/4" cod. KIT1000001

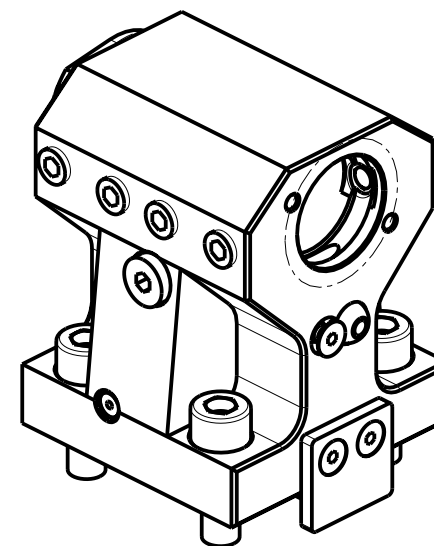

Cod. MT	N°Utensili N°Tools N°Werkzeuge	Reversibile lato mandrino/contromandrino Reversible sub/main spindle side Umkehrbare Spindelseite/ Gegenspindelseite	Lubrificazione int. opzionale Coolant through optional Innenkuehlung Optional	Lubrificazione est. Ext. coolant Aussenkuehlung	Misure Dimensions Masse	D
NKM0113240	1	X	X	X	mm	32

PER BOCCOLE DI RIDUZIONE VEDI PAG. TBL150-1-00
 FOR REDUCING BUSHINGS SEE PAGE TBL150-1-00
 FÜR REDUZIERBUCHSE SIEHE SEITE TBL150-1-00

CMZ
 MOD: TX52 Y3/Y2 QUATTRO/Y2 TW IN - TX66 Y3/Y2 QUATTRO/Y2 TW IN
 PORTAUTENSILE ASSIALE PER BARENO Ø32mm H=80mm
 Axial single boring bar holder Ø32mm H=80mm
 Axial Bohrhälter Ø32mm H=80mm

M.T. srl
 Via Casino Albini 480
 Tel. 0541/956034-957884
 Fax 0541/956341
 47842 S. GIOVANNI IN M. (RN)
 e-mail: mtma@mtmarchetti.com
 http://www.mtmarchetti.com

PRODUZIONE MODULI ROTANTI



PAGINA CMZ665-3-10

Subject to change without notice.

10/2018

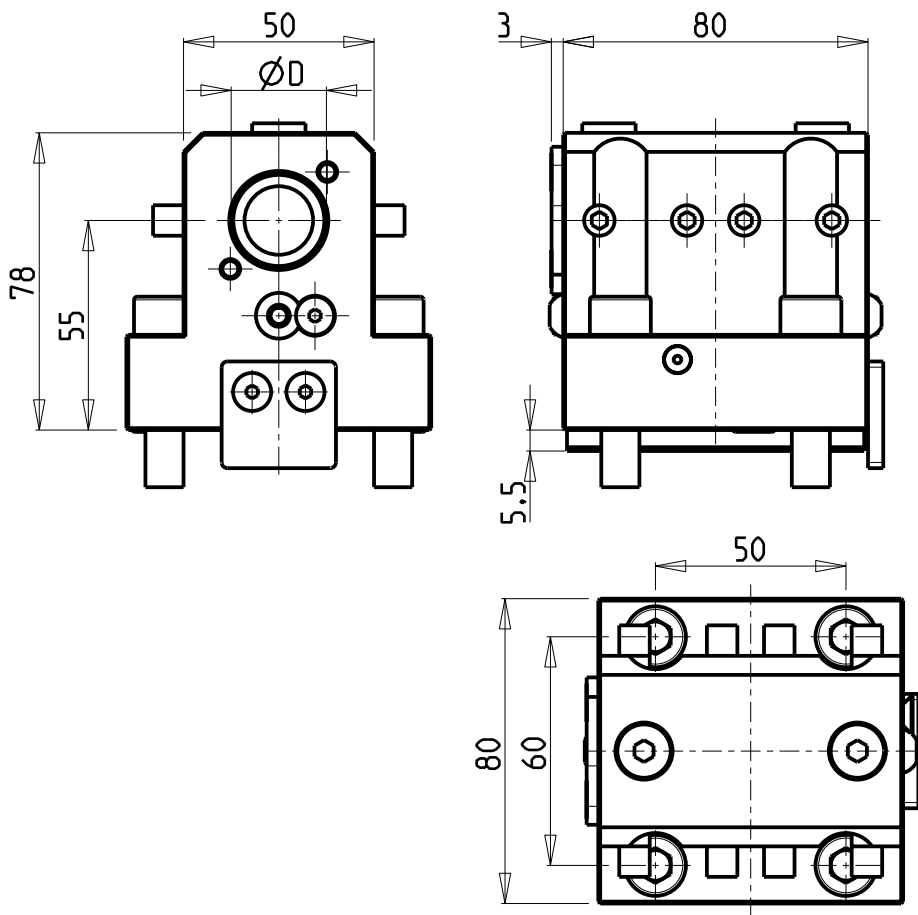

KIT ADDUZIONE INTERNA (OPZIONALE)
 KIT FOR INTERNAL COOLANT (OPTIONAL)
 KIT FUER INTERNE KUEHLMITTELZUFUHR (OPTIONAL)
 Ø25-Ø1" cod. KIT1000006

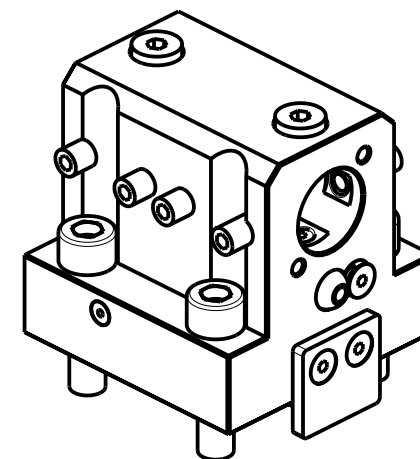
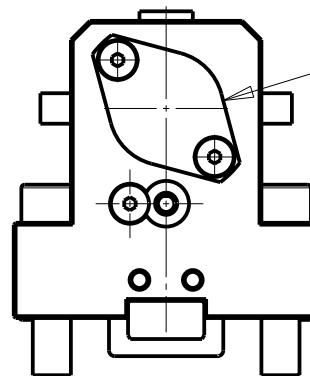

Cod. MT	N°Utensili N° Tools N° Werkzeuge	Reversibile lato mandrino/contromandrino Reversible sub/main spindle side Umkehrbare Spindelseite/ Gegenspindelseite	Lubrificazione int. opzionale Coolant through optional Innenkuehlung Optional	Lubrificazione est. Ext. coolant Aussenkuehlung	Misure Dimensions Masse	D
NKM0112500	1	X	X	X	mm	25
NKM0112510	1	X	X	X	Inch	1"

PER BOCCOLE DI RIDUZIONE VEDI PAG. TBL150-1-00
 FOR REDUCING BUSHINGS SEE PAGE TBL150-1-00
 FÜR REDUZIERBUCHSE SIEHE SEITE TBL150-1-00

CMZ
 MOD: TX52 Y3/Y2 QUATTRO/Y2 TWIN - TX66 Y3/Y2 QUATTRO/Y2 TWIN
 PORTAUTENSILE ASSIALE PER BARENO Ø25mm / Ø1" H=55mm
 Axial single boring bar holder Ø25mm / Ø1" H=55mm
 Axial Bohrhälter Ø25mm / Ø1" H=55mm

M.T. srl
 Via Casino Albini 480
 Tel. 0541/956034-957884
 Fax 0541/956341
 47842 S. GIOVANNI IN M. (RN)
 e-mail: mtma@mtmarchetti.com
 http://www.mtmarchetti.com

PRODUZIONE MODULI ROTANTI



PAGINA CMZ670-3-10

Subject to change without notice.

10/2018

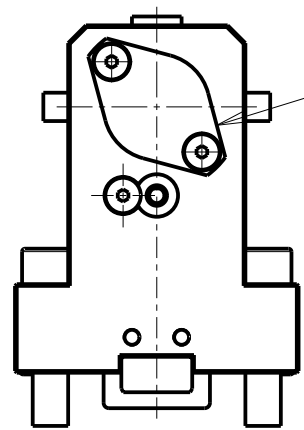
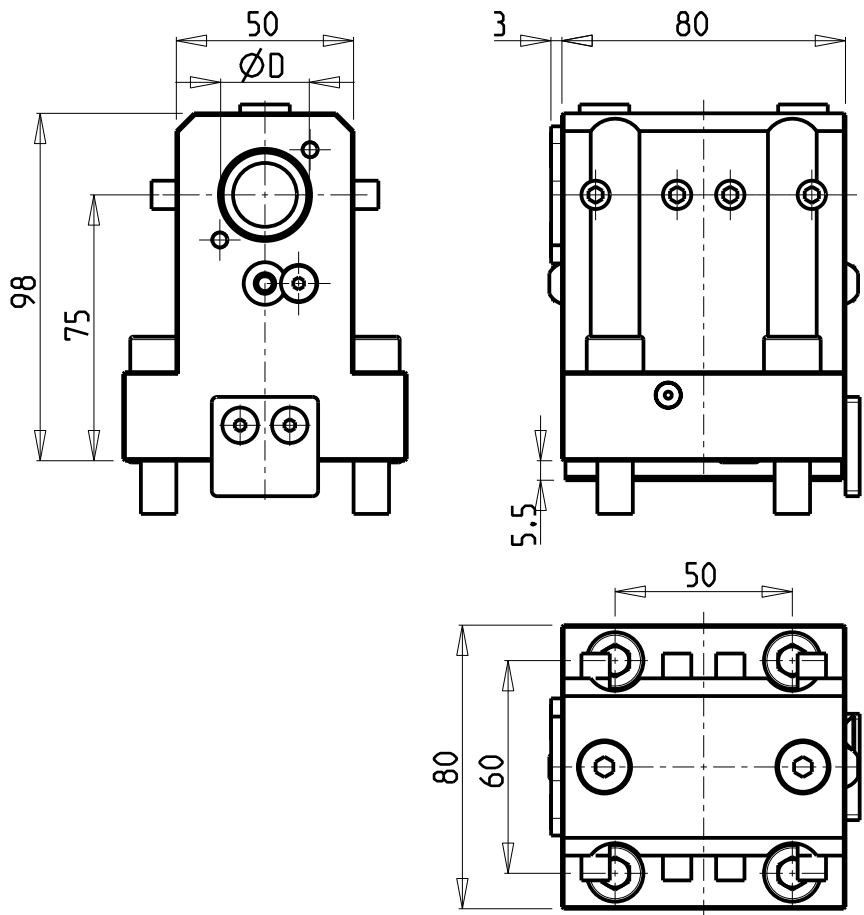

KIT ADDUZIONE INTERNA (OPZIONALE)
 KIT FOR INTERNAL COOLANT (OPTIONAL)
 KIT FUER INTERNE KUEHLMITTELZUFUHR (OPTIONAL)
 Ø25-Ø1" cod. KIT1000006

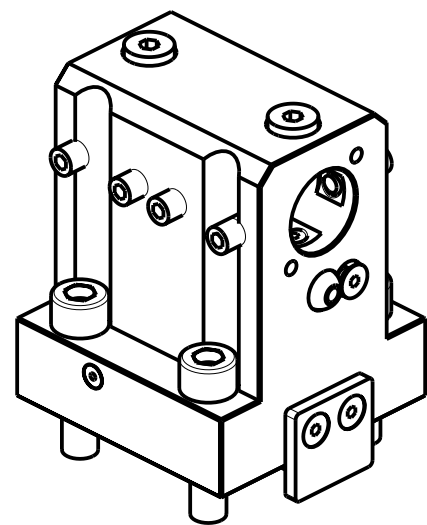

Cod. MT	N°Utensili N° Tools N° Werkzeuge	Reversibile lato mandrino/contromandrino Reversible sub/main spindle side Umkehrbare Spindelseite/ Gegenspindelseite	Lubrificazione int. opzionale Coolant through optional Innenkuehlung Optional	Lubrificazione est. Ext. coolant Aussenkuehlung	Misure Dimensions Masse	D
NKM0112520	1	X	X	X	mm	25
NKM0112530	1	X	X	X	Inch	1"

PER BOCCOLE DI RIDUZIONE VEDI PAG. TBL150-1-00
 FOR REDUCING BUSHINGS SEE PAGE TBL150-1-00
 FUR REDUZIERBUCHSE SIEHE SEITE TBL150-1-00

CMZ
 MOD: TX52 Y3/Y2 QUATTRO/Y2 TWIN - TX66 Y3/Y2 QUATTRO/Y2 TWIN
 PORTAUTENSILE ASSIALE PER BARENO Ø25mm / Ø1" H=75mm
 Axial single boring bar holder Ø25mm / Ø1" H=75mm
 Axial Bohrhalter Ø25mm / Ø1" H=75mm

M.T. srl
 Via Casino Albini 480
 Tel. 0541/956034-957884
 Fax 0541/956341
 47842 S. GIOVANNI IN M. (RN)
 e-mail: mtma@mtmarchetti.com
 http://www.mtmarchetti.com

PRODUZIONE MODULI ROTANTI

 PAGINA CMZ680-3-10

Subject to change without notice.

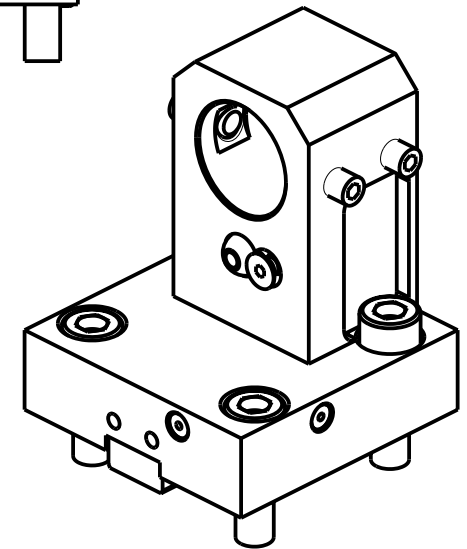
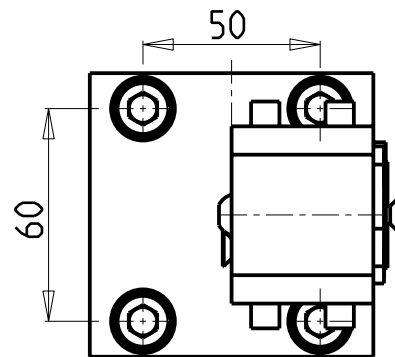
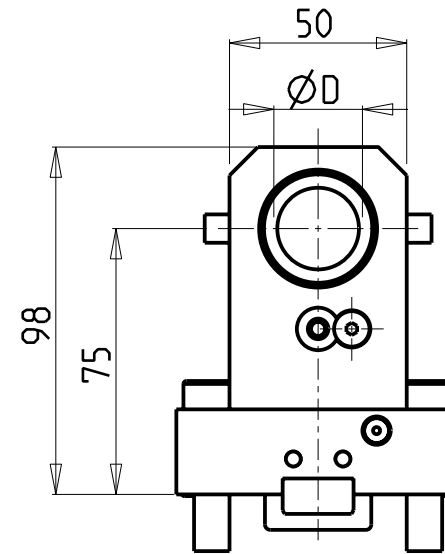
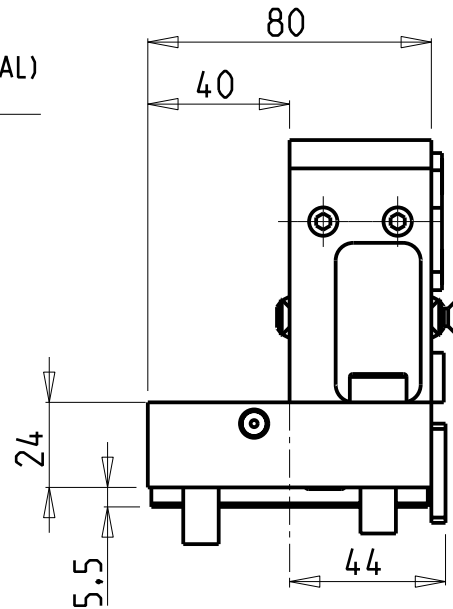
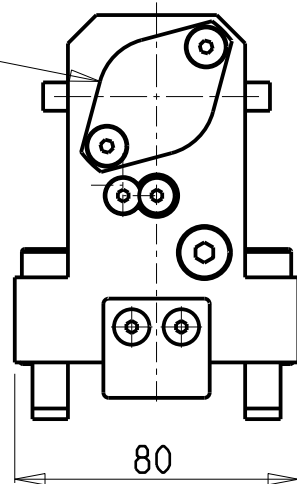
KIT ADDUZIONE INTERNA (OPZIONALE)
 KIT FOR INTERNAL COOLANT (OPTIONAL)
 KIT FUER INTERNE KUEHLMITTELZUFUHR (OPTIONAL)
 Ø32 cod. KIT1000001



PER BOCCOLE DI RIDUZIONE VEDI PAG. TBL150-1-00
 FOR REDUCING BUSHINGS SEE PAGE TBL150-1-00
 FÜR REDUZIERBUCHSE SIEHE SEITE TBL150-1-00

Cod. MT	N°Utensili N°Tools N°Werkzeuge	Reversibile lato mandrino/contromandrino Reversible sub/main spindle side Umkehrbare Spindel-seite/ Gegenspindel-seite	Lubrificazione int. opzionale Coolant through optional Innenkuehlung Optional	Lubrificazione est. Ext. coolant Aussenkuehlung	Misure Dimensions Masse	D
NKM1363200	1	X	X	X	mm	32

CMZ
 MOD: TX52 Y3/Y2 QUATTRO/Y2 TWIN - TX66 Y3/Y2 QUATTRO/Y2 TWIN
 PORTAUTENSILE ASSIALE ARRETRATO PER BARENO Ø32mm H=75mm
 Axial single rear set boring bar holder Ø32mm H=75mm
 Axial Bohrhalter zurueckversetzt Ø32mm H=75mm

M.T. srl
 Via Casino Albini 480
 Tel. 0541/956034-957884
 Fax 0541/956341
 47842 S. GIOVANNI IN M. (RN)
 e-mail: mtma@mtmarchetti.com
 http://www.mtmarchetti.com

PRODUZIONE MODULI ROTANTI

 PAGINA CMZ847-3-10

Subject to change without notice.

10/2018

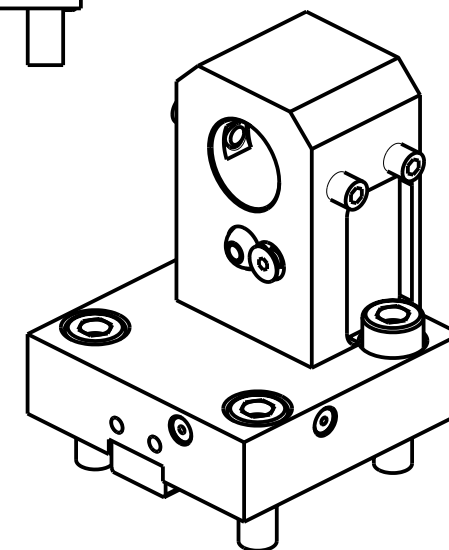
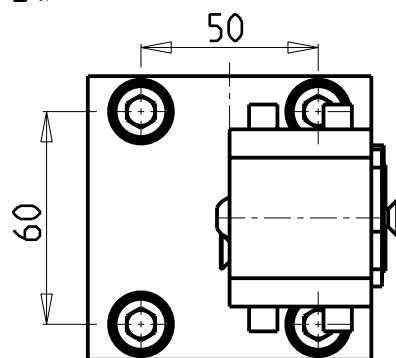
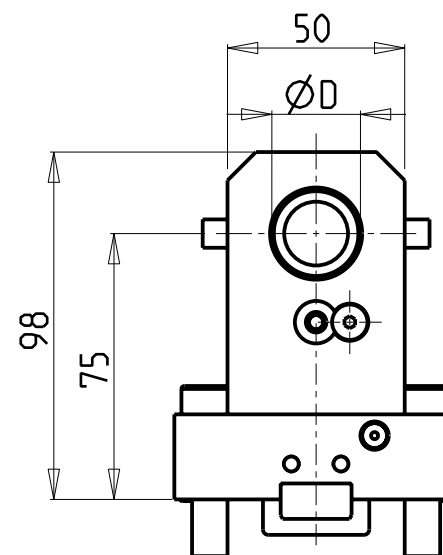
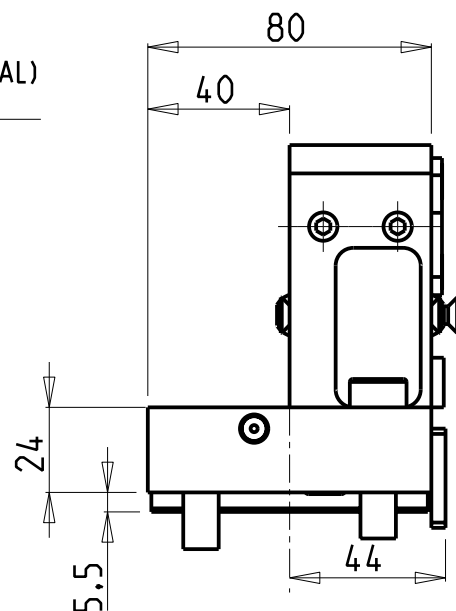
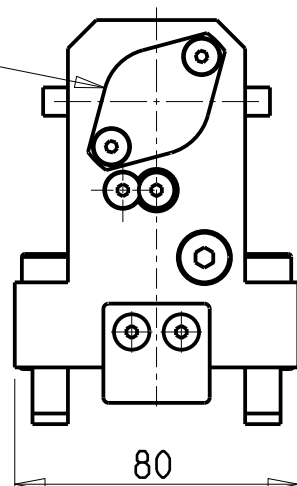
KIT ADDUZIONE INTERNA (OPZIONALE)
 KIT FOR INTERNAL COOLANT (OPTIONAL)
 KIT FUER INTERNE KUEHLMITTELZUFUHR (OPTIONAL)
 Ø25 cod. KIT1000006



PER BOCCOLE DI RIDUZIONE VEDI PAG. TBL150-1-00
 FOR REDUCING BUSHINGS SEE PAGE TBL150-1-00
 FÜR REDUZIERBUCHSE SIEHE SEITE TBL150-1-00

Cod. MT	N°Utensili N°Tools N°Werkzeuge	Reversibile lato mandrino/contromandrino Reversible sub/main spindle side Umkehrbare Spindel-seite/ Gegenspindel-seite	Lubrificazione int. opzionale Coolant through optional Innenkuehlung Optional	Lubrificazione est. Ext. coolant Aussenkuehlung	Misure Dimensions Masse	D
NKM1362500	1	X	X	X	mm	25

CMZ

MOD: TX52 Y3/Y2 QUATTRO/Y2 TW IN - TX66 Y3/Y2 QUATTRO/Y2 TW IN

PORTAUTENSILE ASSIALE ARRETRATO PER BARENO Ø25mm H=75mm

Axial single rear set boring bar holder Ø25mm H=75mm

Axial Bohrhälter zurueckversetzt Ø25mm H=75mm

Subject to change without notice.

M.T. srl

Via Casino Albini 480
 Tel. 0541/956034-957884
 Fax 0541/956341
 47842 S. GIOVANNI IN M. (RN)
 e-mail: mtma@mtmarchetti.com
 http://www.mtmarchetti.com

PRODUZIONE MODULI ROTANTI



PAGINA CMZ848-3-10

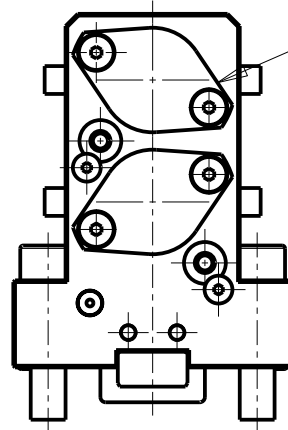
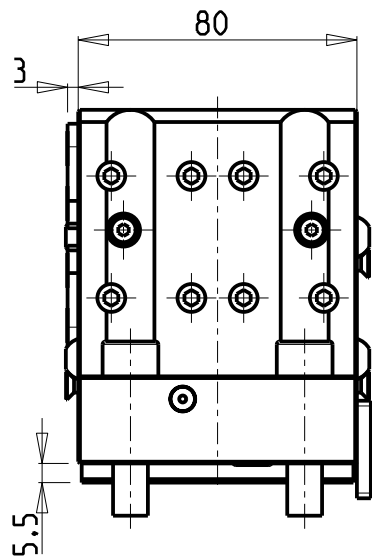
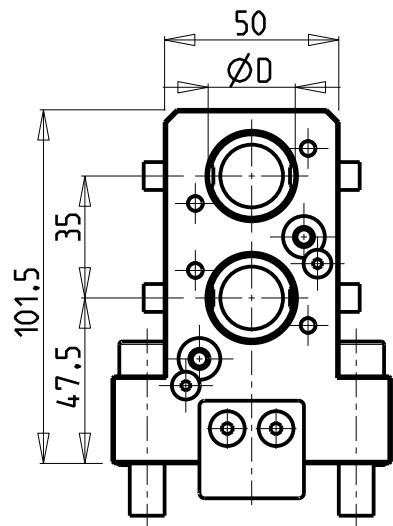

KIT ADDUZIONE INTERNA (OPZIONALE)
 KIT FOR INTERNAL COOLANT (OPTIONAL)
 KIT FUER INTERNE KUEHLMITTELZUFUHR (OPTIONAL)
 Ø25-Ø1" cod. KIT1000006

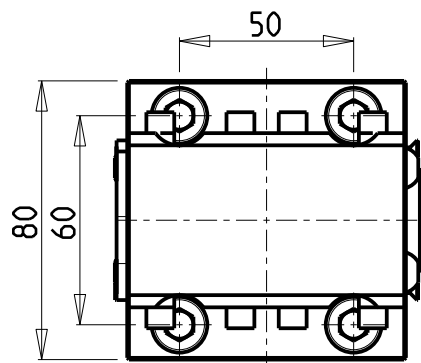
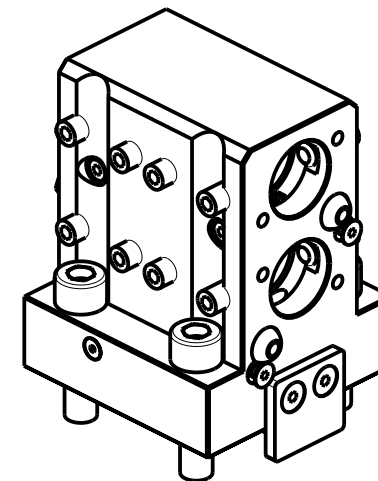

PER BOCCOLE DI RIDUZIONE VEDI PAG. TBL150-1-00
 FOR REDUCING BUSHINGS SEE PAGE TBL150-1-00
 FÜR REDUZIERBUCHSE SIEHE SEITE TBL150-1-00

Cod. MT	N°Utensili N°Tools N°Werkzeuge	Reversibile lato mandrino/contromandrino Reversible sub/main spindle side Umkehrbare Spindel-seite/ Gegenspindel-seite	Lubrificazione int. opzionale Coolant through optional Innenkuehlung Optional	Lubrificazione est. Ext. coolant Aussenkuehlung	Misure Dimensions Masse	D
NKM0142500	2	X	X	X	mm	25
NKM0142510	2	X	X	X	Inch	1"

CMZ

MOD: TX52 Y3/Y2 QUATTRO/Y2 TW IN - TX66 Y3/Y2 QUATTRO/Y2 TW IN

PORTAUTENSILE ASSIALE PER BARENO 2 POSIZIONI Ø25mm / Ø1"

Axial double boring bar holder Ø25mm / Ø1"

Axial Bohrhalter 2 Positionen Ø25mm / Ø1"

Subject to change without notice.

M.T. srl

Via Casino Albini 480

Tel. 0541/956034-957884

Fax 0541/956341

47842 S. GIOVANNI IN M. (RN)

e-mail: mtma@mtmarchetti.com

http://www.mtmarchetti.com

PRODUZIONE MODULI ROTANTI



PAGINA CMZ864-3-00

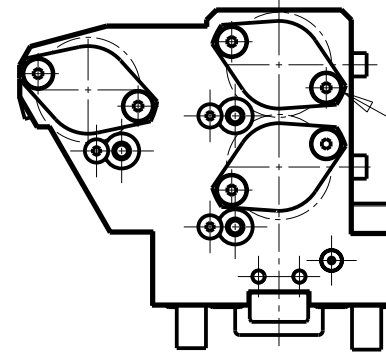
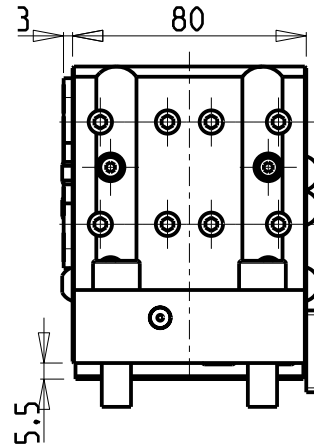
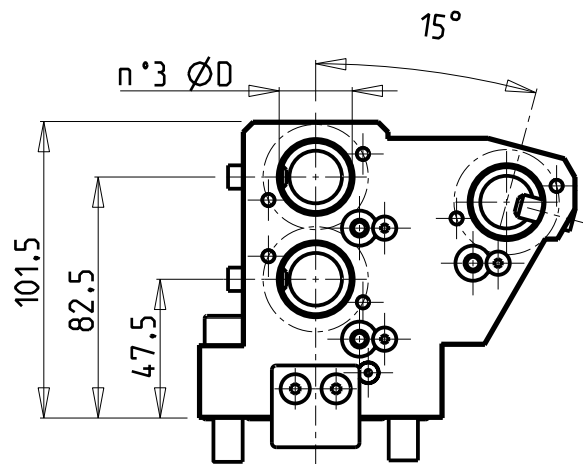

KIT ADDUZIONE INTERNA (OPZIONALE)
 KIT FOR INTERNAL COOLANT (OPTIONAL)
 KIT FUER INTERNE KUEHLMITTELZUFUHR (OPTIONAL)
 Ø25-Ø1" cod. KIT1000006

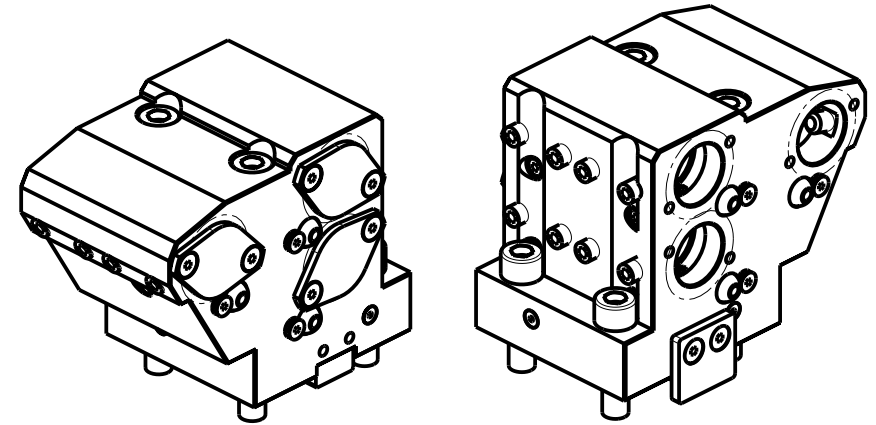
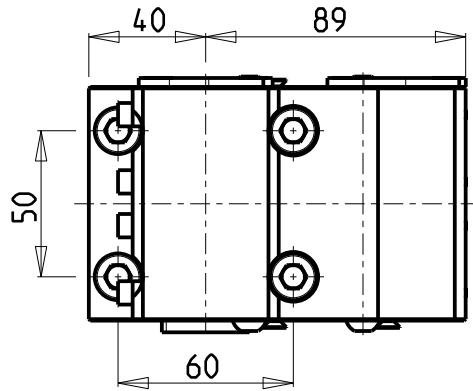

PER BOCCOLE DI RIDUZIONE VEDI PAG. TBL150-1-00
 FOR REDUCING BUSHINGS SEE PAGE TBL150-1-00
 FÜR REDUZIERBUCHSE SIEHE SEITE TBL150-1-00

Cod. MT	N°Utensili N°Tools N°Werkzeuge	Reversibile lato mandrino/contromandrino Reversible sub/main spindle side Umkehrbare Spindel-seite/ Gegenspindel-seite	Lubrificazione int. opzionale Coolant through optional Innenkuehlung Optional	Lubrificazione est. Ext. coolant Aussenkuehlung	Misure Dimensions Masse	D
NKM0211000	3	X	X	X	mm	25
NKM0212540	3	X	X	X	Inch	1"

CMZ

MOD: TX52 Y3/Y2 QUATTRO/Y2 TW IN - TX66 Y3/Y2 QUATTRO/Y2 TW IN

PORTAUTENSILE ASSIALE PER BARENO 3 POSIZIONI Ø25mm / Ø1"

Axial 3 position boring bar holder Ø25mm / Ø1"

Axial Bohrhalter 3 Positionen Ø25mm / Ø1"

Subject to change without notice.

M.T. srl

Via Casino Albini 480
 Tel. 0541/956034-957884
 Fax 0541/956341
 47842 S. GIOVANNI IN M. (RN)
 e-mail: mtma@mtmarchetti.com
 http://www.mtmarchetti.com

PRODUZIONE MODULI ROTANTI



PAGINA CMZ884-3-00

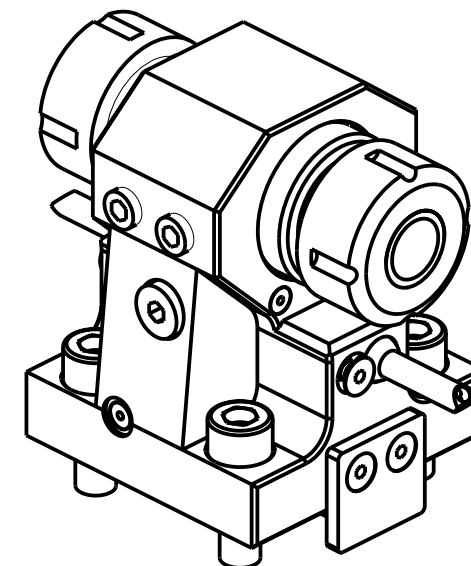
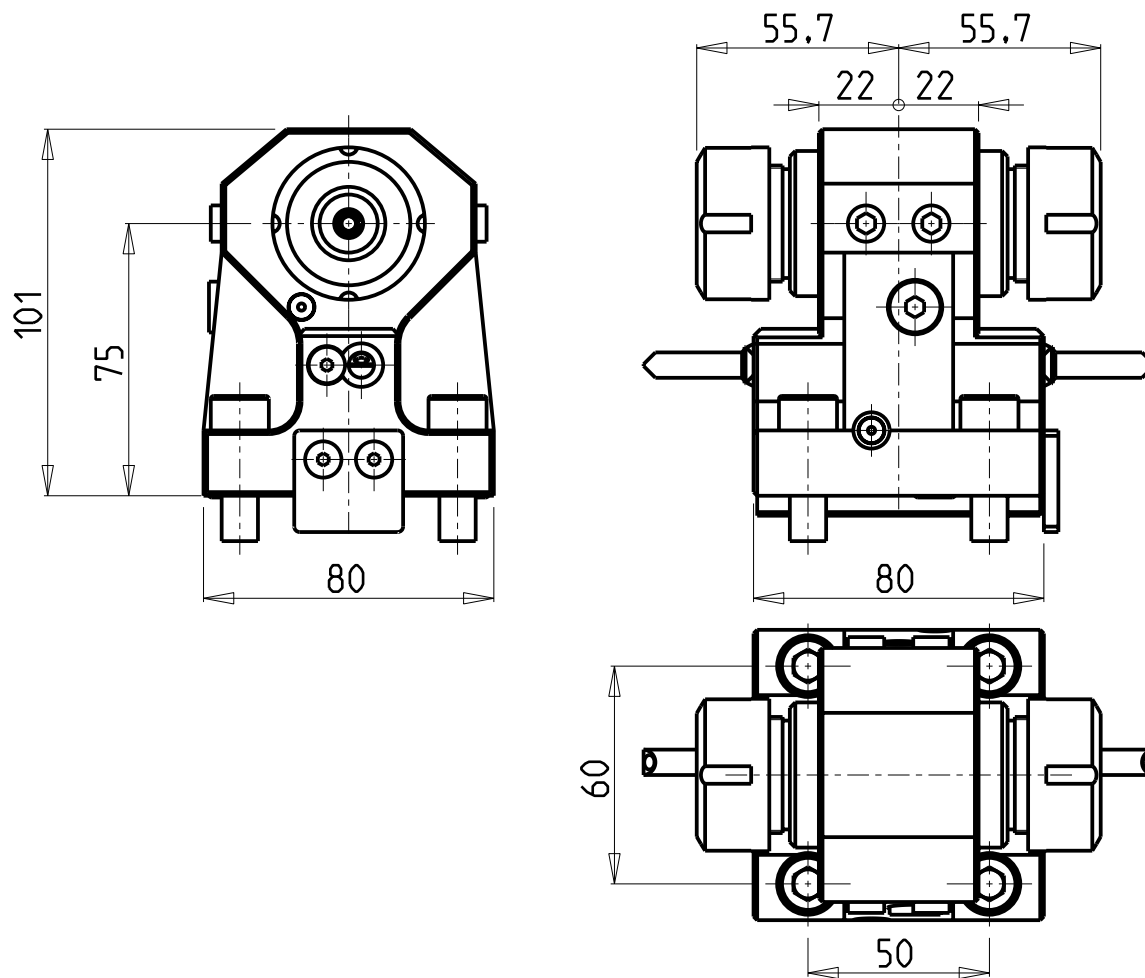

Cod. MT	N°Utensili N°Tools N°Werkzeuge	Mandrino Spindle Spindel	Reversibile lato mandrino/contromandrino Reversible sub/main spindle side Umkehrbare Spindel-seite/ Gegenspindel-seite	Lubr.interna Coolant through Innenkuehlung	Lubrificazione est. Ext. coolant Aussenkuehlung	CHIAVI NON INCLUDE Keys not included Schlüssel nicht einbegriffen
NKM1452525	2	ER25+ER25	X	X	X	CHSTER25

CMZ
 MOD: TX52 Y3/Y2 QUATTRO/Y2 TW IN - TX66 Y3/Y2 QUATTRO/Y2 TW IN
 PORTAUTENSILE ASSIALE BISPORGENTE PORTAPINZA H=75mm
 Axial double collet chuck holder H=75mm
 Axial Doppel-Spannzangenhalter H=75mm

M.T. srl
 Via Casino Albini 480
 Tel. 0541/956034-957884
 Fax 0541/956341
 47842 S. GIOVANNI IN M. (RN)
 e-mail: mtma@mtmarchetti.com
 http://www.mtmarchetti.com

PRODUZIONE MODULI ROTANTI



PAGINA CMZ940-3-00

Subject to change without notice.

10/2018

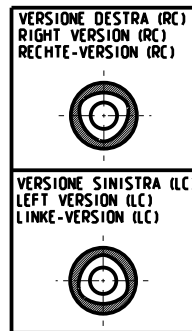
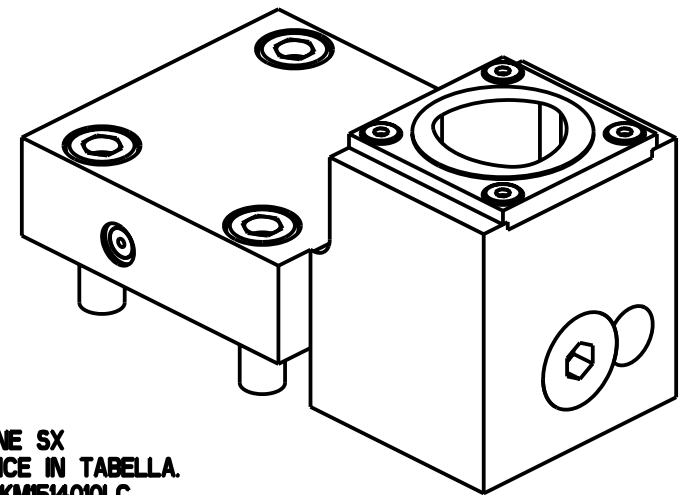
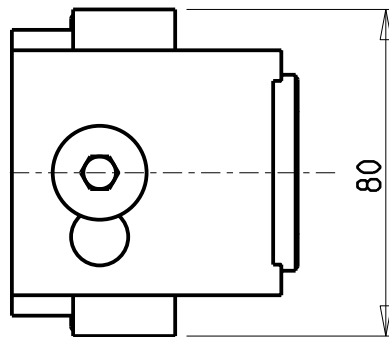
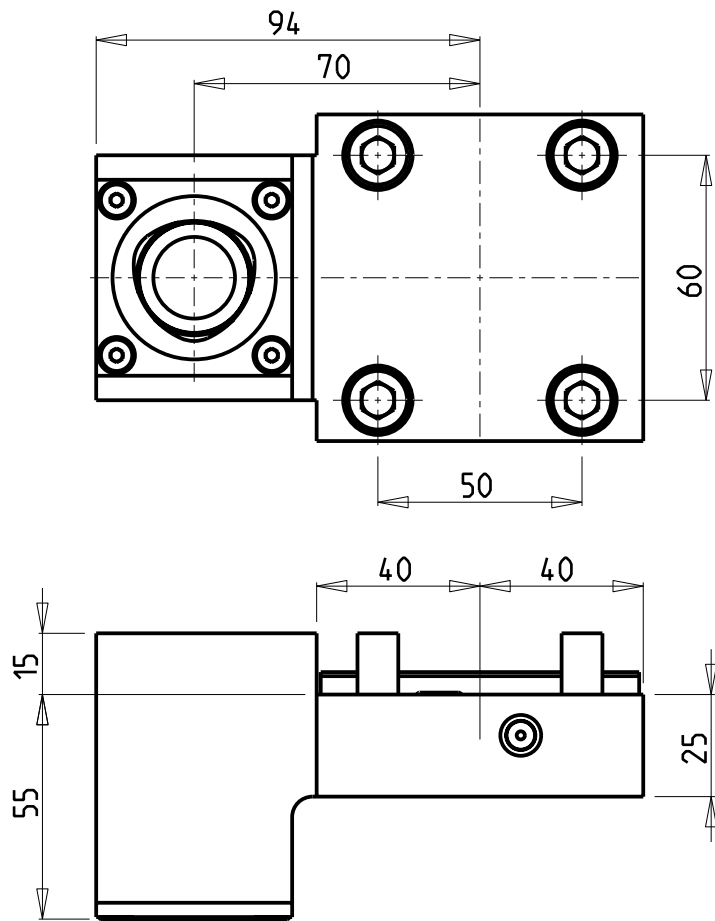

PER ORDINARE LA VERSIONE SX
AGGIUNGERE "LC" AL CODICE IN TABELLA.
ES: NKM1514010 DIVENTA NKM1514010LC

TO ORDER LEFT VERSION
ADD A "LC" IN THE CODE-CHARTS.
EXAMPLE: NKM1514010 BECOMES NKM1514010LC

UM DIE LINKE-VERSION ZU BESTELLEN, BEI DER
ARTIKELBEZEICHNUNG "LC" HINZUFUEGEN.
BEISPIEL: NKM1514010 WIRD DANN NKM1514010LC

Cod. MT	Lubrificazione int. Coolant through Innenkuehlung	Reversibile lato mandrino/contromandrino Reversible sub/main spindle side Umkehrbare Spindel-seite/ Gegenspindel-seite	TAGLIA Size Masse
NKM1514010	X	X	C4

CMZ
MOD: TX52 Y3/Y2 QUATTRO/Y2 TWIN - TX66 Y3/Y2 QUATTRO/Y2 TWIN

PORTAUTENSILE RADIALE SINGOLO ARRETRATO MT CAPTO
Single rear-set radial static tool MT CAPTO
Radial Single-Werkzeughalter zurueckversetzt MT CAPTO

Subject to change without notice.

M.T. srl
Via Casino Albini 480
Tel. 0541/956034-957884
Fax 0541/956341
47842 S. GIOVANNI IN M. (RN)
e-mail: mtma@mtmarchetti.com
http://www.mtmarchetti.com

PRODUZIONE MODULI ROTANTI



PAGINA CMZ430-C-40

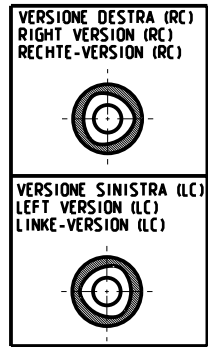
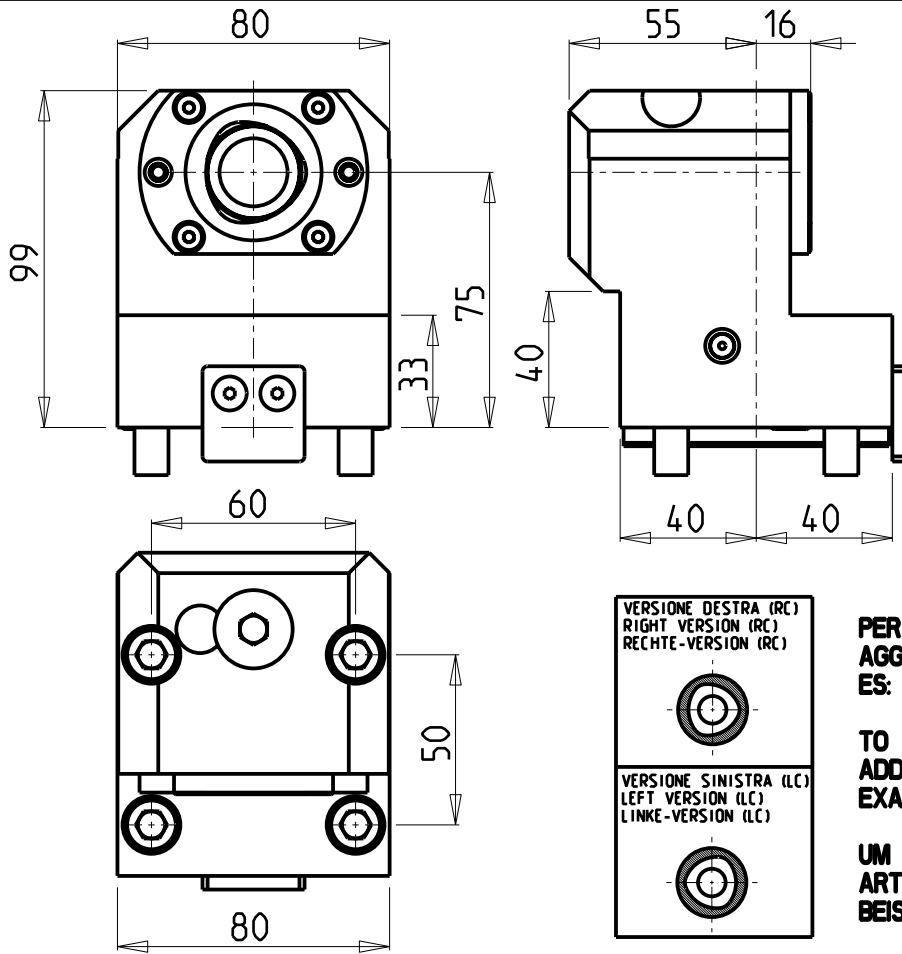

PER ORDINARE LA VERSIONE SX
 AGGIUNGERE "LC" AL CODICE IN TABELLA.
 ES: NKM1524010 DIVENTA NKM1524010LC

TO ORDER LEFT VERSION
 ADD A "LC" IN THE CODE-CHARTS.
 EXAMPLE: NKM1524010 BECOMES NKM1524010LC

UM DIE LINKE-VERSION ZU BESTELLEN, BEI DER
 ARTIKELBEZEICHNUNG "LC" HINZUFUEGEN.
 BEISPIEL: NKM1524010 WIRD DANN NKM1524010LC

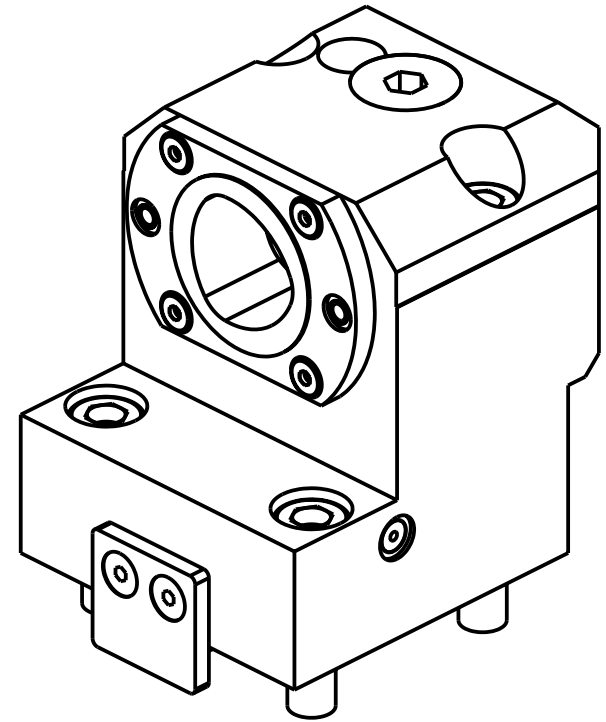

Cod. MT	Lubrificazione int. Coolant through Innenkuehlung	Reversibile lato mandrino/contromandrino Reversible sub/main spindle side Umkehrbare Spindelseite/ Gegenspindelseite	TAGLIA Size Masse
NKM1524010	X	X	C4

CMZ
 MOD: TX52 Y3/Y2 QUATTRO/Y2 TWIN - TX66 Y3/Y2 QUATTRO/Y2 TWIN
 PORTAUTENSILE ASSIALE SINGOLO ARRETRATO MT CAPTO
 Axial rear-set boring single static tool MT CAPTO
 Axial Single-Werkzeughalter zurueckversetzt MT CAPTO

M.T. srl
 Via Casino Albini 480
 Tel. 0541/956034-957884
 Fax 0541/956341
 47842 S. GIOVANNI IN M. (RN)
 e-mail: mtma@tmarchetti.com
 http://www.mtmarchetti.com

PRODUZIONE MODULI ROTANTI

PAGINA CMZ555-C-40

Subject to change without notice.